

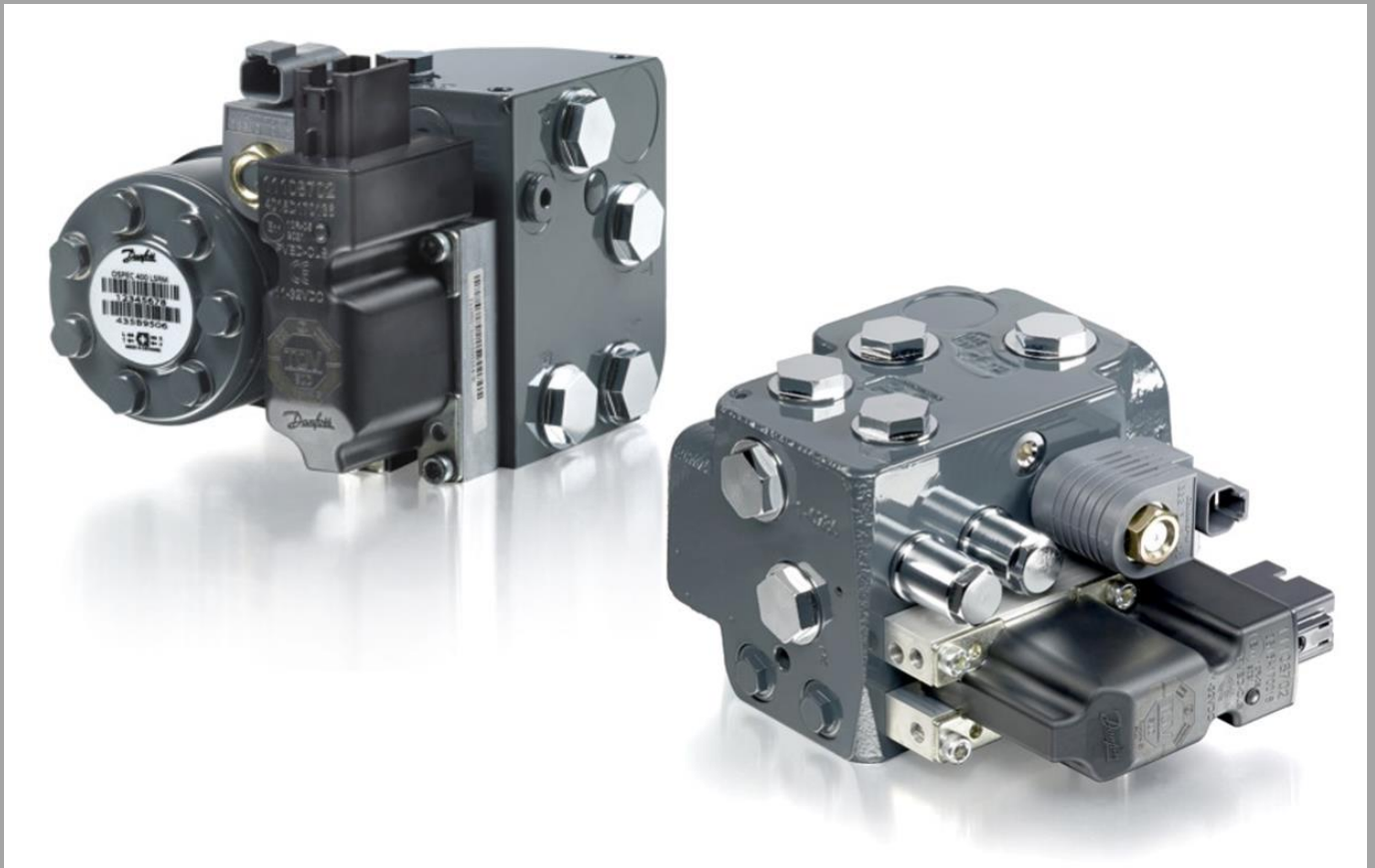

PVED-CLS Controller For Electrohydraulic Steering

User Manual



Software version 2.02





Important User Information

Danfoss is not responsible or liable for indirect or consequential damages resulting from the use or application of this equipment.

The examples and diagrams in this manual are included for illustration purposes. Due to the many variables and requirements associated with any particular installation, Danfoss cannot assume responsibility or liability for the actual used bases on the examples and diagrams.

Reproduction of whole or part of the contents of this manual is prohibited.

The following notes are used to raise awareness of safety considerations.

<p>Warning</p> 	<p>Identifies information about practices or circumstances that can cause a hazardous situation, which may lead to personal injury or death, damage or economic loss.</p>
<p>Attention</p> 	<p>Identifies information about practices or circumstances that can lead to personal injury or death, property damage, or economic loss. Attentions help you identify a hazard, avoid a hazard, and recognize the consequence.</p>
<p>Important</p>	<p>Identifies information that is critical for successful application and understanding of the product.</p>
<p>Recommendation</p>	<p>Identifies a typical use of a functionality or parameter value. Use recommendations as a starting point for the final configuration process of the system.</p>



Revisions and references

Revision history

Date	Change	Revision
31 st of August 2013	1 st draft	0.50
20 th of December 2013	2 nd draft – SW. 1.72	0.90
14 th of April 2014	3 rd draft – SW. 1.82	0.95
12 th of September 2014	4 th draft – SW 1.90	0.98
28 th of November 2014	5 th draft – SW 1.91 (User manual + parameter description)	0.99
16 th of February 2015	6 th draft – SW 1.92	0.992
27 th of March 2015	7 th draft – SW 1.93	0.995
10 th of July 2015	8 th draft – SW 1.93	0.999
28 th of October 2015	Updated for 1.95 Software release	1.1
20 th of November 2015	Updated according to internal review (#1347)	1.11
24 th of November 2015	Updated to match communication protocol for 1.95 release	1.12
05 th of December 2015	Updated the high level state machines	1.13
16 th of February 2016	Updated for typos. Aligned parameter names to corresponding .PID-file (service tool page)	1.14
14 th of April 2016	Typos for Anti-jerk default values corrected (both AUX and STW). Update to the Anti-jerk descriptions (both Out from spool neutral position and STW). Missing figure 3 and added Auto-guidance description	1.15
28 th of April 2016	Updated for 1.96 software release	1.2
20 th of July 2016	Updated according to internal review (#1597)	1.2.1
22 nd of July 2016	Updated for 1.97 software release	1.3
16 th of March 2017	Correction of typos & layout, implementation of EHi-content	1.3.1
30 th of March, 2017	Updated for 1.98 Software release	1.4
15 th of September, 2017	Updated for 2.00 Software release	1.5
14 th of May 2018	Updated for 2.01 Software release	1.6
14 th of January 2019	Updated for 2.02 Software release	1.7

Document references

Literature
EHPS Steering Valve, PVE Actuation, OSPCX CN Steering Unit
OSPE Steering valve, SASA sensor, Technical Information
PVED-CLS Communication Protocol
PVED-CLS KWP2000 Protocol
PVED-CLS Safety Manual
PVED-CLS Technical Information
EHi Technical Information
Operating/Safety Manual for J4F with 351JCM

Definitions and Abbreviates

μC	Micro-Controller
AD	Analogue-to-Digital
AD1-AD3	Analogue Input 1-3 on PVED-CLS
AgPI	Agriculture Performance Level
AUX	Auxiliary
BOOL	Boolean
CAN	Controller Area Network
ccm	Cubic Centimeters
COV	Cut-Off Valve
CRC	Cyclic Redundancy Check
DC	Direct Current
dDeg	Deci degrees
dec	Decimal
DTC	Diagnostic Trouble Code
ECU	Electronic Control Unit
EEPROM	Electrically Erasable Programmable Read-Only Memory
EFU	Electronic Follow-up Unit
EH	Electro-Hydraulic
EHi	Electro-Hydraulic Inline Valve
EHi-E	Electro-Hydraulic Inline Valve - Electronic Override
EHi-H	Electro-Hydraulic Inline Valve - Hydraulic Override
EHPS	Electro-Hydraulic Power Steering
FDA	Fault Detection Algorithm
FIFO-principle	First-in-first-out-principle
FMI	Failure Mode Identifier
GMS	Guidance Machine Status
GPS	Global Positioning System and Danfoss “short call-name” for Auto-guidance
IMD	Internal Monitoring Disengage
IR	Internal Resolution [0.1%]
ISOBUS	Communication Protocol (ISO 11783)
KWP2000	Keyword Protocol 2000
LED	Light Emitting Diode
LVDT	Linear Variable Differential Transformer
mAmp	Milliamps
MMI	Man-Machine Interface
mVolts	Millivolts
OEM	Original Equipment Manufacturer
OSP	Orbital Steering Product
OSPCX	Orbital Steering Product - Including valve function and X-release
OSPE	Orbital Steering Product – Electro-Hydraulic
P1D	file format extension for files to be used by PLUS+1 SERVICE TOOL
PSAC	Parameter Sector Approval Code
PVE	Proportional Valve Electronic
PVED-CLS	Proportional Valve Electronic Digital – Closed Loop Steering
PWM	Pulse-Width Modulation
SASA	Steering Angle Sensor - Absolute
SEHS	Safe Electro-Hydraulic Steering
SIL	Safety Integrity Level



SPN	Suspect Parameter Number
STW	Steering Wheel
SVB	Solenoid Valve Bridge
SVC	Solenoid Valve Control
TI	Technical Information
U16	Unsigned - 16 bit
U8	Unsigned - 8 bit
VDC	Voltage - Direct Current
WAS	Wheel Angle Sensor
x 10u Meter	times 10 micro-meter
x100msec	times 100 milliseconds
x10mSec	times 10 milliseconds
XID	Extended Message Identifier

Table of Contents

1	GENERAL INFORMATION	10
1.1	Steering input devices	10
1.2	CAN interface.....	11
1.3	Power-up.....	11
1.4	CAN bus protocol	11
1.5	DC power supply.....	11
2	SYSTEM OVERVIEW	12
2.1	OSPE & EHi systems.....	12
2.2	EHPS System.....	15
3	PVED-CLS FUNCTIONAL OVERVIEW.....	17
3.1	PVED-CLS system overview	17
3.2	PVED-CLS steering mode selection state machine	18
3.3	Steering wheel state machine.....	19
3.4	AUX steering state machine.....	20
3.5	Auto-guidance steering state machine.....	20
3.6	State transition requirements description	23
3.6.1	Steering wheel related conditions.....	23
3.6.2	Auxiliary steering device (AUX) related conditions.....	23
3.6.3	Auto-guidance related conditions	25
3.6.4	Vehicle speed dependent conditions.....	26
3.6.5	Other conditions.....	26
4	PARAMETER CONFIGURATION	27
4.1	Parameter setup procedure – good practice.....	28
5	INSTALLATION	29
5.1	Connector interface.....	29
5.2	PVED-CLS LED diagnostic	30
6	MAPPING A STEERING DEVICE/SENSOR	31
6.1.1	Valid Sensor Combinations.....	31
7	HYDRAULIC AND PERIPHERALS CONFIG.....	34
7.1	Cut-off valve.....	34
7.1.1	Cut-off valve control	34
7.1.2	Cut-off valve monitoring.....	37
7.1.2.1	Cut-off valve monitoring for OSPE, EHi-E.....	37
7.1.2.2	Cut-off valve monitoring for EHi-H.....	38
7.2	Road switch.....	39
7.2.1.1	Road switch monitoring.....	41
7.3	EH steering disengage method	41



7.3.1.1	Internal monitoring disengage (IMD).....	42
7.4	Valve capacity.....	43
7.5	LVDT compensation and spool threshold at boot-up.....	44
7.5.1.1	LVDT compensation.....	44
7.5.1.2	Spool threshold at boot-up.....	44
7.6	Analogue interface.....	45
7.6.1.1	AD low-pass filter.....	45
7.6.1.2	Analogue input drift compensation.....	45
7.6.1.3	Sensor supply test.....	46
7.7	Steering device and program changes.....	46
7.8	Vehicle speed setup.....	47
7.9	Vehicle geometry.....	48
7.10	Setup a steering device.....	50
8	EXTERNAL SENSORS.....	51
8.1	Wheel angle sensor.....	51
8.1.1	No Wheel angle sensor.....	51
8.2	Speed sensor.....	52
8.3	SASAIID sensor.....	52
9	CALIBRATION.....	53
9.1	Wheel angle sensor calibration.....	54
9.1.1	Automatic adjustment of maximum steer angles and cylinder stroke volume.....	55
9.2	Analogue Joystick calibration.....	61
9.3	Spool calibration.....	61
9.3.1	Prerequisites.....	61
9.3.2	Spool calibration overview.....	62
9.4	Auto-calibration.....	64
9.4.1	Initial setup.....	65
9.4.1.1	Auto-calibration parameter plausibility check.....	66
9.5	Execute auto-calibration from plus+1 service tool.....	69
9.5.1	Pre-requisite.....	69
9.5.2	Execute WAS auto-calibration from the PLUS+1 SERVICE TOOL.....	69
9.5.3	Execute Analogue Joystick auto-calibration from the PLUS+1 SERVICE TOOL.....	73
9.5.4	Execute spool auto-calibration from the PLUS+1 SERVICE TOOL.....	77
9.5.4.1	Fine-tuning of parameters for spool calibration.....	81
10	STEERING WHEEL PROGRAMS.....	82
10.1	Block diagram.....	82
10.2	Backlash.....	82
10.3	STW in use and activation threshold.....	83
10.4	Vehicle speed dependent Fast-steering.....	83
10.4.1	Compensate steering sensitivity according to wheel angle range.....	85
10.5	Anti-drift (EFU).....	86
10.6	Anti-jerk.....	88
10.6.1	Calculation of flow set-point using anti-jerk functionality.....	89
10.7	Soft-stop.....	92
11	AUX STEERING.....	94

11.1	Block diagram	95
11.1.1	Open loop mini-wheel.....	95
11.1.2	Open loop joystick	95
11.1.3	Closed loop joystick	95
11.2	AUX config.....	95
11.2.1	AUX Joystick Config – Open Loop Mode	95
11.2.2	AUX Joystick Config – Closed Loop Mode	95
11.2.3	AUX Config – Mini-steering wheel.....	96
11.3	Open loop filter	97
11.4	Open loop mini-wheel – vehicle speed dependent Fast-steering.....	98
11.4.1	Compensate steering sensitivity according to wheel angle range	99
11.5	Open loop mini-wheel anti-drift (EFU).....	101
11.6	Open loop anti-jerk	102
11.6.1	Calculation of flow set-point using anti-jerk functionality	103
11.7	Open loop soft stop.....	106
11.8	Open loop joystick – Transfer function	107
11.9	Open loop joystick – vehicle speed dependent flow scaling	109
11.10	Closed loop joystick – vehicle speed dependent wheel angle limitation	111
11.11	Closed loop joystick – vehicle speed dependent closed loop control	113
11.12	AUX Type - Elobau Joystick.....	115
11.12.1	Validation of Elobau Joystick Position Status	116
11.12.2	Validation and Scaling of Elobau Joystick Position	116
11.12.3	Time guarding on Elobau Joystick Messages:	116
11.12.4	Elobau Joystick - Parameter Configuration	117
12	AUTO-GUIDANCE STEERING	118
12.1	Block diagram	118
12.2	Selection of GPS algorithm type.....	118
12.3	GPS config	120
12.4	Vehicle speed dependent wheel angle limitation.....	122
12.5	Vehicle speed dependent closed loop control.....	124
12.6	Vehicle speed dependent flow command limitation	127
12.7	Vehicle speed dependent wheel angle speed limitation	129
13	SAFE ON-ROAD MODE.....	131
14	FDA	132
15	DIAGNOSTICS AND TROUBLESHOOTING.....	135
15.1	Diagnostics.....	135
15.2	Troubleshooting – typical faults	136
16	ERRATA INFORMATION	137
17	APPENDIX	138
17.1	Parameter Cross Check.....	138
17.2	Error codes	141
17.3	FMI list.....	147
17.4	Parameter list.....	148

17.4.1	Hydraulic config	148
17.4.2	SEHS FDA	149
17.4.3	Valve Calibration.....	150
17.4.4	CAN WAS Calibration Data.....	150
17.4.5	Analog Sensor Calibration Data.....	151
17.4.6	Peripherals Config.....	152
17.4.7	SEHS Protocol Data	153
17.4.8	Internal Monitoring.....	155
17.4.9	Vehicle Geometry.....	157
17.4.10	GPS Config	158
17.4.11	STW Config.....	159
17.4.12	AUX Config.....	161
17.4.13	Production/Calibration Flag	163
17.4.14	Auto Calibration Config	164
17.4.15	OEM Data.....	166
17.5	CRC sector	166
17.5.1	CRC sector overview.....	166
17.5.2	Sector CRC calculation.....	167
17.5.3	Example.....	167
17.5.4	Signature CRC calculation	167
17.5.5	Example.....	168
17.6	Manual calibration of WAS, Joystick and spool.....	169
17.6.1	Production/calibration flag	169
17.6.2	Calibrating analogue wheel angle sensor	169
17.6.3	Calibrating CAN-based wheel angle sensor	171
17.6.4	Calibrating Analogue Joystick.....	173
17.6.5	Manual spool calibration.....	175
17.6.5.1	Spool calibration overview	175
17.6.5.2	Spool calibration procedure.....	176
17.6.5.2.1	Determining the closed loop dead-bands	176
17.6.5.2.2	Determining the open loop dead-bands.....	176
17.6.5.2.3	Calibration procedure	177
17.6.5.2.4	Closed loop dead-band calibration.....	178
17.6.5.2.5	Open loop dead-band calibration	179
17.6.5.2.6	Determining TL and TR for a specific vehicle type	179
17.6.5.3	Post conditions.....	180



1 General information

As user comfort receives higher and higher focus along with higher demands for automation and safety, new technologies are necessary to take on this challenge. The new technologies are using electro-hydraulics, combining hydraulic power with electronics and computer power.

Electro-hydraulic steering system has the advantages over pure hydraulic steering systems such as the ability to meet specific functionalities on request.

Increasing demand shows a trend for a higher safety-level up to AgPl “d” for off-road driving.

In order to give this functionality Danfoss has developed the PVED-CLS. The PVED-CLS is based on Danfoss PVE technology, as used in electro hydraulic proportional valves for decades. PVE modules are used with PVG spool valves and dedicated spool valves for steering applications, OSPE and EHPS as well as the EHi-E and EHi-H systems.

The PVED-CLS is designed according to state-of-the-art standards regarding functional safety, including ISO 13849, EN 16590 (ISO 25119) and IEC 65108. Dedicated safety functions are integrated that offer suitable risk reduction, when applied in accordance with Danfoss recommendations.

In combination with the OSPE/EHi-E steering unit the PVED-CLS forms a category 3 architecture according to ISO 13849. Achievable performance level is “d” for electro hydraulic steering, which makes the OSPE/EHi and PVED-CLS combination suitable for off road application, for instance with typical agricultural vehicles. Actual required performance level for any particular vehicle should be determined through appropriate hazard and risk assessment.

Important

The OEM is fully responsible for making and documenting their own hazard and risk assessment and can only use the Danfoss documentation as input for their own hazard and risk assessment.

For more safety related details on OSPE/EHi-E, EHi-H and EHPS, with PVED-CLS, please see the Danfoss document, PVED-CLS Safety Manual.

1.1 STEERING INPUT DEVICES

The PVED-CLS can utilize a variety of steering input devices:

- Steering wheel sensor – SASA
- Auxiliary mini-steering wheel
- Auxiliary open loop joystick
 - CAN based
 - Analogue
 - Elobau®
- Auxiliary closed loop joystick
 - CAN based
- ISOBUS curvature commands

Both a SASA and an auxiliary steering device may exist simultaneously on the CAN bus in a steering system, though only one of the three auxiliary steering devices can be configured per steering system.

For SASA and mini-steering wheel, up to five individual predefined steering programs may be configured for fast-steer, and made available through the vehicle MMI.

In order to utilize a closed loop joystick a wheel angle sensor must be present in the system.

The PVED-CLS supports ISOBUS 11783 curvature commands (format-option to support GMS message according to ISO11783-7:2009 or ISO11783-7:2015 by parameter P3326), as well as input from a Danfoss SASA steering wheel sensor



1.2 CAN INTERFACE

Danfoss recommends installation of steering related CAN nodes on a separate CAN bus, in order to avoid excessive bus load. In some situations, particularly when several status messages are enabled, the PVED-CLS and accompanying CAN nodes may occupy most of the useful bandwidth of a 250K CAN bus.

Danfoss recommend that installation guidelines from CAN bus standard J1939/15 are followed (unshielded twisted pair (UTP), etc.)

1.3 POWER-UP

During power-up the PVED-CLS will typically complete its boot sequence after ~1800ms. At this time an address claim message will be issued on the CAN bus. Following the address claim the PVED-CLS will go into WAS calibration service mode as default (provided that no prior calibrations have been done and PVED-CLS is setup with default parameters).

After the WAS has been calibrated and the PVED-CLS has been power-cycled, PVED-CLS will go into spool dead-band calibration service mode.

When the spool dead-band calibration is performed and the PVED-CLS has been reset (power-cycle or software-reset), an initialization period of max 10 seconds is started, to allow speed sensor messages, MMI messages, WAS messages/signal, AUX messages, SASA messages and Road switch signal to boot and appear on the CAN bus or input pins.

Once in operation mode the CAN messages and analogue signals are periodically validated and must remain present for the PVED-CLS to remain in operation mode. The validation period is configurable for each signal. In case a mapped message disappears from the CAN bus, analogue signals are disconnected or signal crosscheck fails, the PVED-CLS will enter safe state and remain non-operational until a reset is completed. Missing curvature commands are exceptions and does not put PVED-CLS to safe state. A reset may be either a power cycle sequence or a soft reset CAN message. For more details, please see the Danfoss document- PVED-CLS communication Protocol.

1.4 CAN BUS PROTOCOL

The PVED-CLS conforms to CAN bus standard J1939. Access to reading is provided through the KWP2000 and PVED-CLS Communication protocols and modifying configuration parameters is provided through the KWP2000 protocol. Please see the Danfoss documents, PVED-CLS KWP2000 Protocol and PVED-CLS communication Protocol.

1.5 DC POWER SUPPLY

The PVED-CLS is designed to operate reliably with both 12V and 24V battery voltage, as used on typical agricultural vehicles. Internal voltage regulators allow fluctuations on supply voltage terminals from 5.5V to 35.5V, but the PVED-CLS will sent out an INFO level DTC if the supply goes below 9V, but will not enter safe state. Below 9V the electrohydraulic functions of an EHPS, EHi and OSPE cannot be guaranteed to work properly. In case the supply voltage exceeds 35.5V, a DTC is issued on the CAN bus, and the PVED-CLS will enter safe state. If the power supply goes below 5.5V the PVED-CLS will shut down.

Experience shows that excessively low supply voltage may occur during engine cranking in cold conditions, depending on the state of battery charge, and/or general state of battery.



2 System overview

2.1 OSPE & EHI SYSTEMS

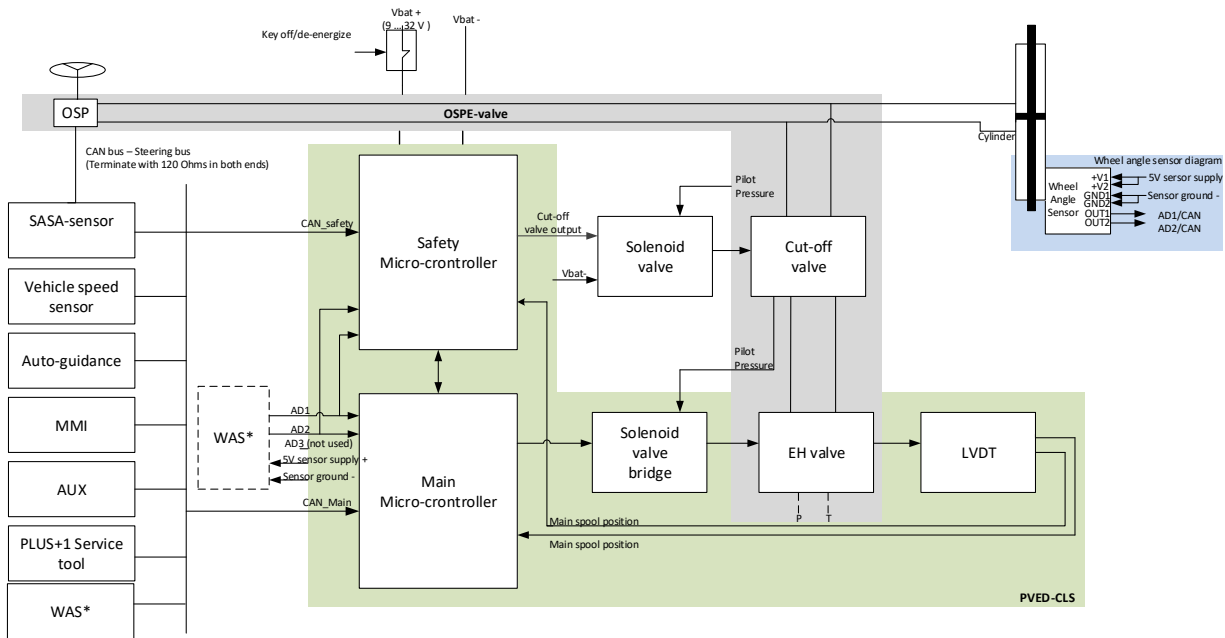

Figure 1 OSPE System

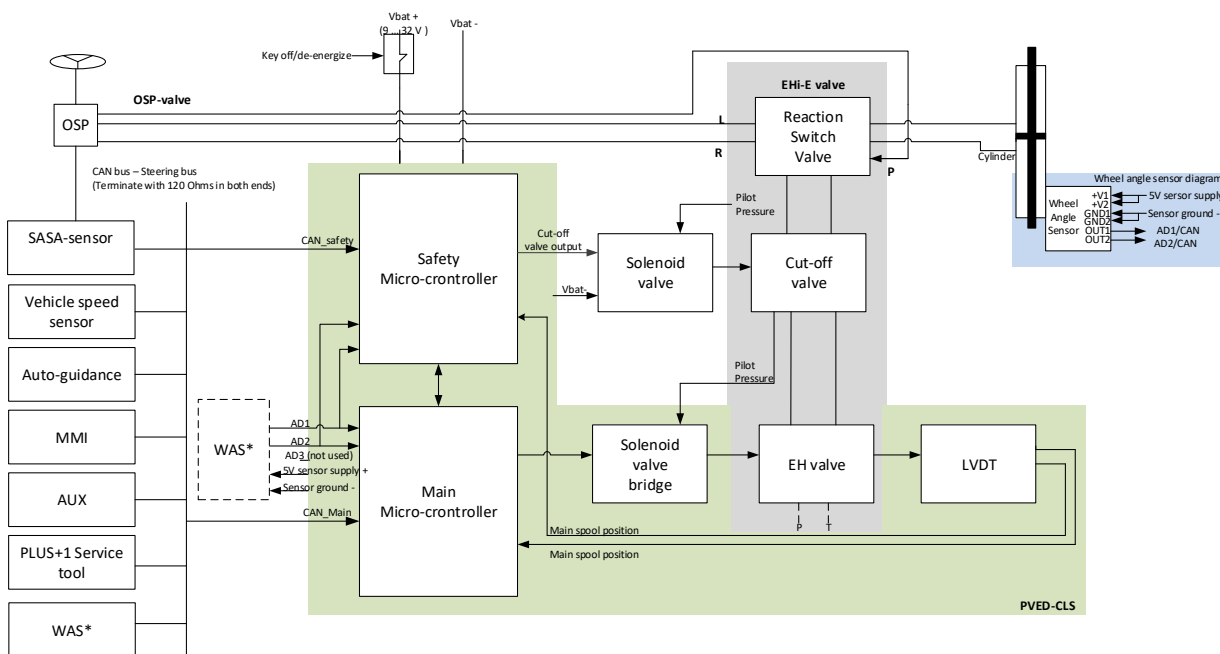

Figure 2 EHI-E System

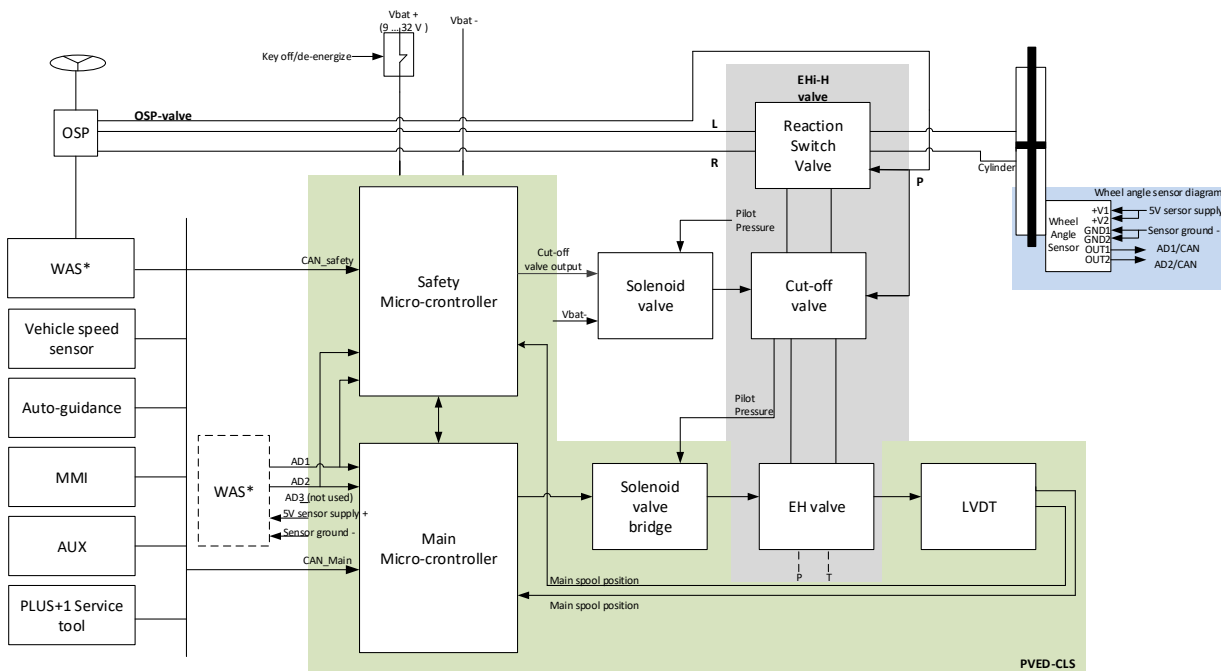

Figure 3 EHi-H System

In a OSPE (Figure 1) and EHi-E (Figure 2) with PVED-CLS, a Danfoss SASA-sensor and a two channel vehicle speed sensor, a MMI interface (for changing programs, steering devices, steering modes etc.) on the CAN bus are prerequisite in order to complete the OSPE and EHi-E systems. In an EHi-H system, see figure 3, a two-channel vehicle speed sensor and an MMI interface (for changing programs, steering devices, steering modes etc.) are prerequisite to complete the EHi-H system. Depending on the application, up to two auto-guidance controllers and one auxiliary steering device (e.g. mini-wheel, joystick) can be configured together with the PVED-CLS in an OSPE, EHi-E or EHi-H system.

When the PVED-CLS is mounted on an OSPE/EHi-E/EHi-H the cut-off valve is always present, therefore P3072 needs to be 255 and the valve type needs to be set to OSPE/EHi-E or EHi-H by setting P3081 to 0 or 2 respectively. Furthermore OSP displacement, given in ccm, needs to be entered in P3084. If the OSP displacement is unknown, it can be found on the Danfoss label, located at the end cover of the steering unit.

The cylinder stroke volume is also needed, again in ccm. If effective cylinder volume is unknown, count the steering wheel turns lock-to-lock and multiply by OSP-displacement, to get the effective cylinder volume. The value needs to be entered in P3086.

A wheel angle sensor (WAS*), is marked "*" because, either analogue or CAN-based, is required for auto guidance, for steering wheel soft-stop as well as for EFU and closed loop steering. Danfoss recommend a redundant sensor as illustrated on Figure 1 & 2, to meet category 3 according to ISO13849.



Name	Address	Data type	Unit	Description of parameter	User	Range		Danfoss default value	Safety critical parameters 'S'
						Min.	Max.		
Cut-off valve present	P3072	U8	-	Cut-off Valve Present/Not Present Valid Values: 0 (NOT PRESENT); 255 (PRESENT)	OEM	0	255	255	S
Valve type	P3081	U8	-	Valve type on which the PVED-CLS is mounted Valid Values: 0 (OSPE, EHi-E); 1 (EHPS); 2 (EHi-H)	OEM	0	2	0	S
OSP displacement	P3084	U16	ccm	OSP displacement, number of cubic centimeters per revolution Note: When the PVED-CLS is mounted on an EHPS this parameter must be set equal to 0!	OEM	0	120 0	120	S
Cylinder stroke volume	P3086	U16	ccm	Cylinder stroke volume. Acceptable values: 100-10000. Note: Writing values >10000 will force to use automatic adjusted cylinder stroke volume-value on WAS calibration	OEM	100	655 35	500	S

Table 1

For further information on how to design steering-system and sensor sub-systems, please refer to the following:

- OSPE Steering valve Technical information
- SASA sensor Technical information
- PVED-CLS Safety Manual
- EHi Technical information

Important

The number of steering wheel turns Lock-to-lock is dependent on following:

- *OSP displacement*
- *EH-spool and pilot flow*
- *Standby pressure (spring force)*
- *Cylinder volume*



2.2 EHPS SYSTEM

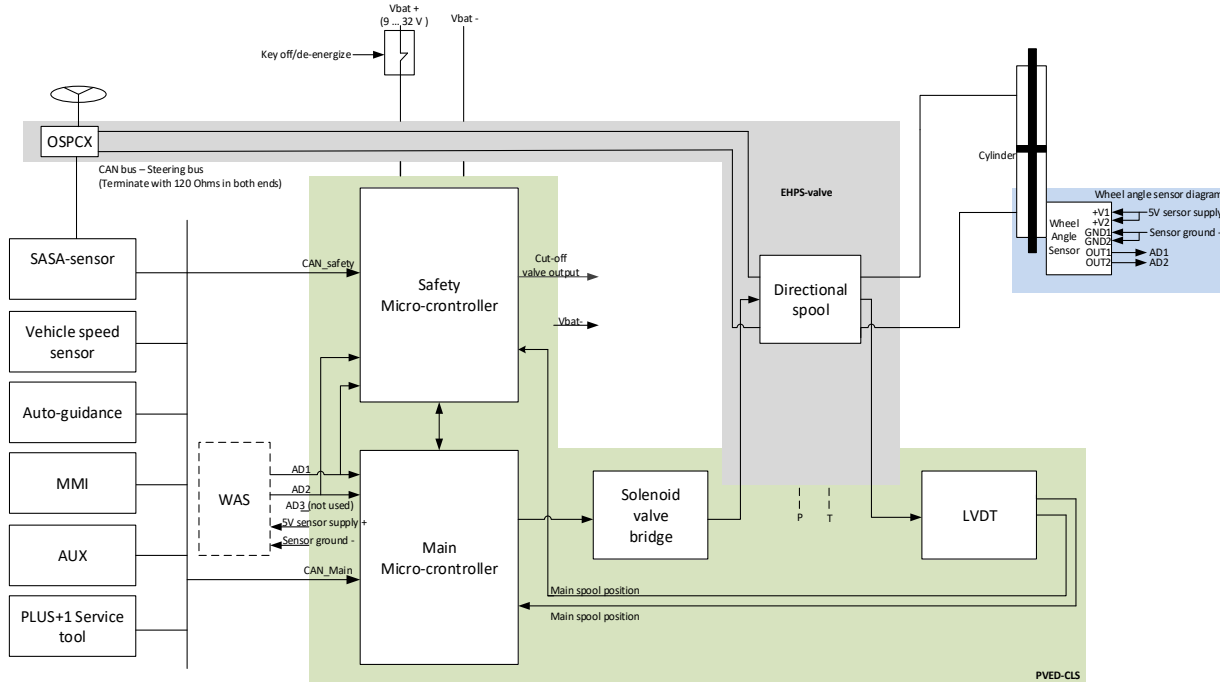

Figure 4 EHPS System

In a EHPS with PVED-CLS, a wheel angle sensor (Danfoss recommend a redundant sensor like illustrated on Figure , to meet category 2 according to ISO13849) either analogue or CAN-based, a Danfoss SASA-sensor and two channel vehicle speed sensor on the CAN bus are prerequisite in order to get the PVED-CLS up and running. The system also requires an MMI installed (for changing programs, steering devices, steering modes etc.). Additionally, an auto guidance controller and/or an auxiliary device (e.g. mini-wheel, joystick) can be connected to the CAN bus if auto-guidance and/or auxiliary device steering are required.

When the PVED-CLS is mounted on an EHPS the cut-off valve is not present, therefore P3072 needs to be 0 and the valve type needs to be set to EHPS by setting P3081 to 1. Furthermore, as the flow direction in an EHPS compared to OSPE/EHi-E and EHi-H is inverted, the PVED-CLS need to be provided with this information, which can be done by setting P3080 to 255.

The cylinder stroke volume is needed, in ccm. It needs to be entered in P3086 and the number of steering wheel turns lock-to-lock, without activating the PVED-CLS needs to be entered in P3082.

Important

The OSP displacement (P3084) must be set to 0, when the PVED-CLS is mounted on an EHPS!

The number of steering wheel turns Lock-to-lock is dependent on following:

- *EH-spool and pilot flow*
- *Standby pressure (spring force)*
- *Cylinder volume*

Contact your local technical support at Danfoss Power Solutions for specific calculation, or simply do the measurement/exercise on the vehicle.



Name	Address	Data type	Unit	Description of parameter	User	Range		Danfoss default value	Safety critical parameters 'S'
						Min.	Max.		
Cut-off valve present	P3072	U8	-	Cut-off Valve Present/Not Present Valid Values: 0 (NOT PRESENT); 255 (PRESENT)	OEM	0	255	255	S
Invert flow direction	P3080	U8	-	Changes the direction of the requested flow Valid Values: 0 (NO, DEFAULT OSPE/EHi); 255 (YES, DEFAULT EHPS)	OEM	0	255	0	S
Valve type	P3081	U8	-	Valve type on which the PVED-CLS is mounted Valid Values: 0 (OSPE, EHi-E); 1 (EHPS); 2 (EHi-H)	OEM	0	2	0	S
Turns lock-to-lock EHPS	P3082	U16	-	Number of steering wheel turns lock-to-lock, without PVED-CLS activated (hence pure hydraulic Resolution: 0.01 turns)	OEM	100	1000	450	S
OSP displacement	P3084	U16	ccm	OSP displacement, number of cubic centimeters per revolution Note: When the PVED-CLS is mounted on an EHPS this parameter must be set equal to 0!	OEM	0	1200	120	S
Cylinder stroke volume	P3086	U16	ccm	Cylinder stroke volume. Acceptable values: 100-10000. Note: Writing values >10000 will force to use automatic adjusted cylinder stroke volume-value on WAS calibration	OEM	100	65535	500	S

Table 2

For further information on how to design steering-system and sensor sub-systems, please refer to the following:

- OSPE Steering valve Technical information
- SASA sensor Technical information
- PVED-CLS Safety Manual
- EHPS Steering Valve, PVE Actuation, OSPCX CN Steering Unit



3 PVED-CLS functional overview

3.1 PVED-CLS SYSTEM OVERVIEW

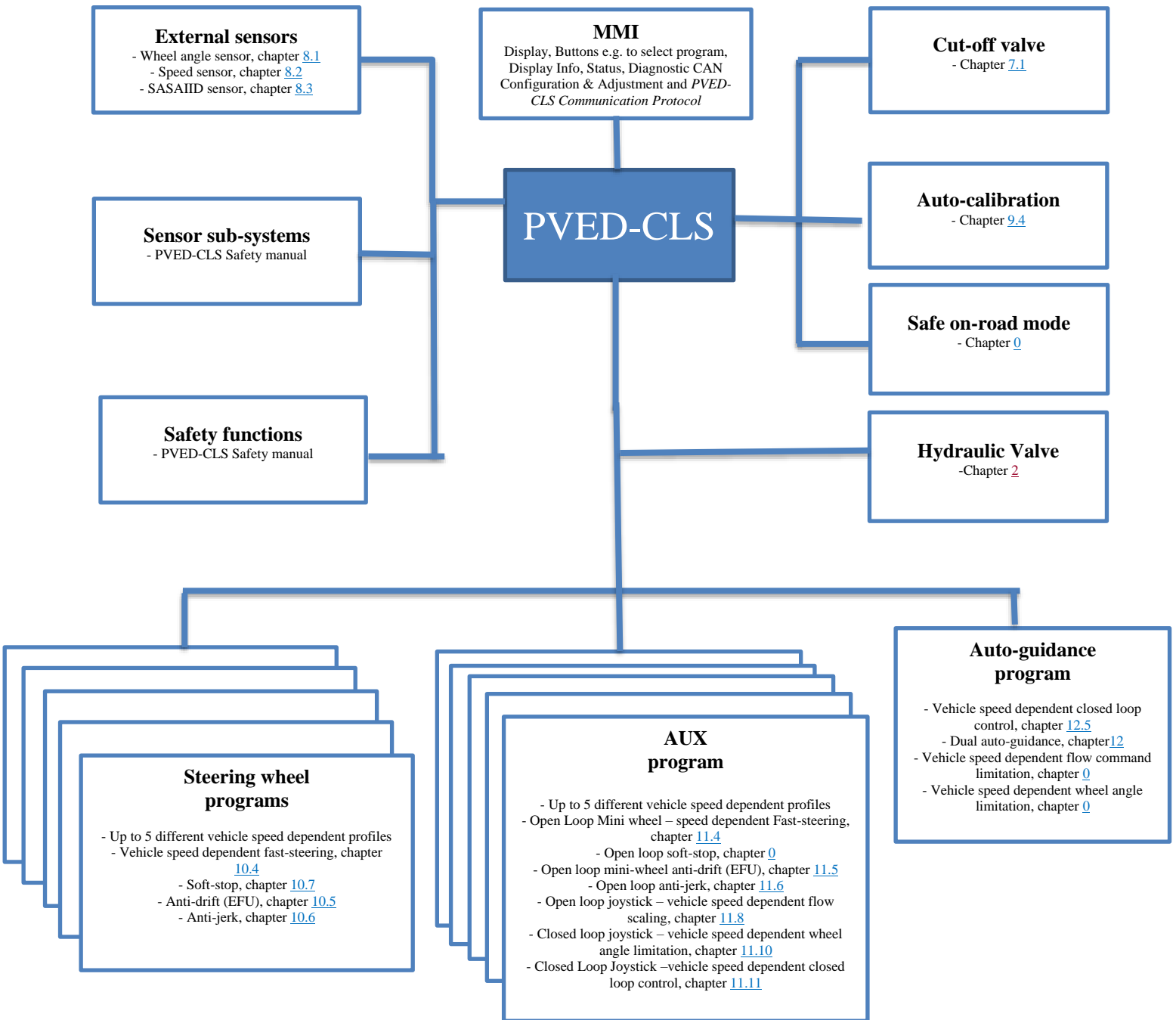



3.2 PVED-CLS STEERING MODE SELECTION STATE MACHINE

Figure 5 shows the high level steering mode selection state machine. The state transition requirements are described in detail in chapter 3.6. The operational states of PVED-CLS can be observed in ‘Operation status message’, (refer PVED-CLS Communication Protocol document for more details).

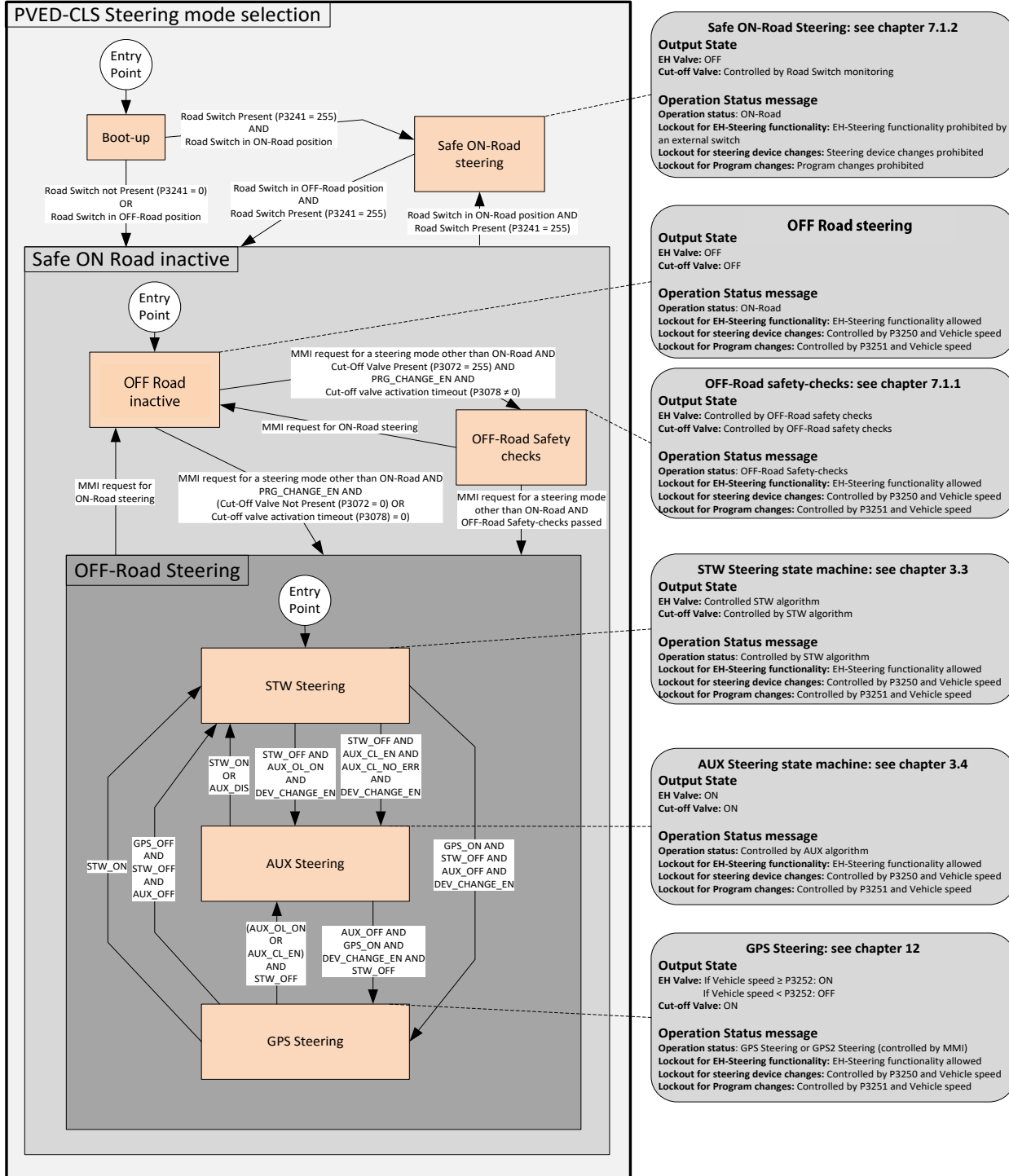

Figure 5



3.3 STEERING WHEEL STATE MACHINE

Figure shows the steering wheel algorithm state machine.

The entry point in below state machine is after the successful OFF road safety checks. Based on the EH steering disengage method parameter P3254 (SASA or IMD), the further transition of states is determined for steering with SASA or steering with IMD.

In Steering wheel program 1 – 5, the EH-Valve is active and the PVED-CLS behavior can be configured individually. Find additional information on how to setup the programs in chapter 10.

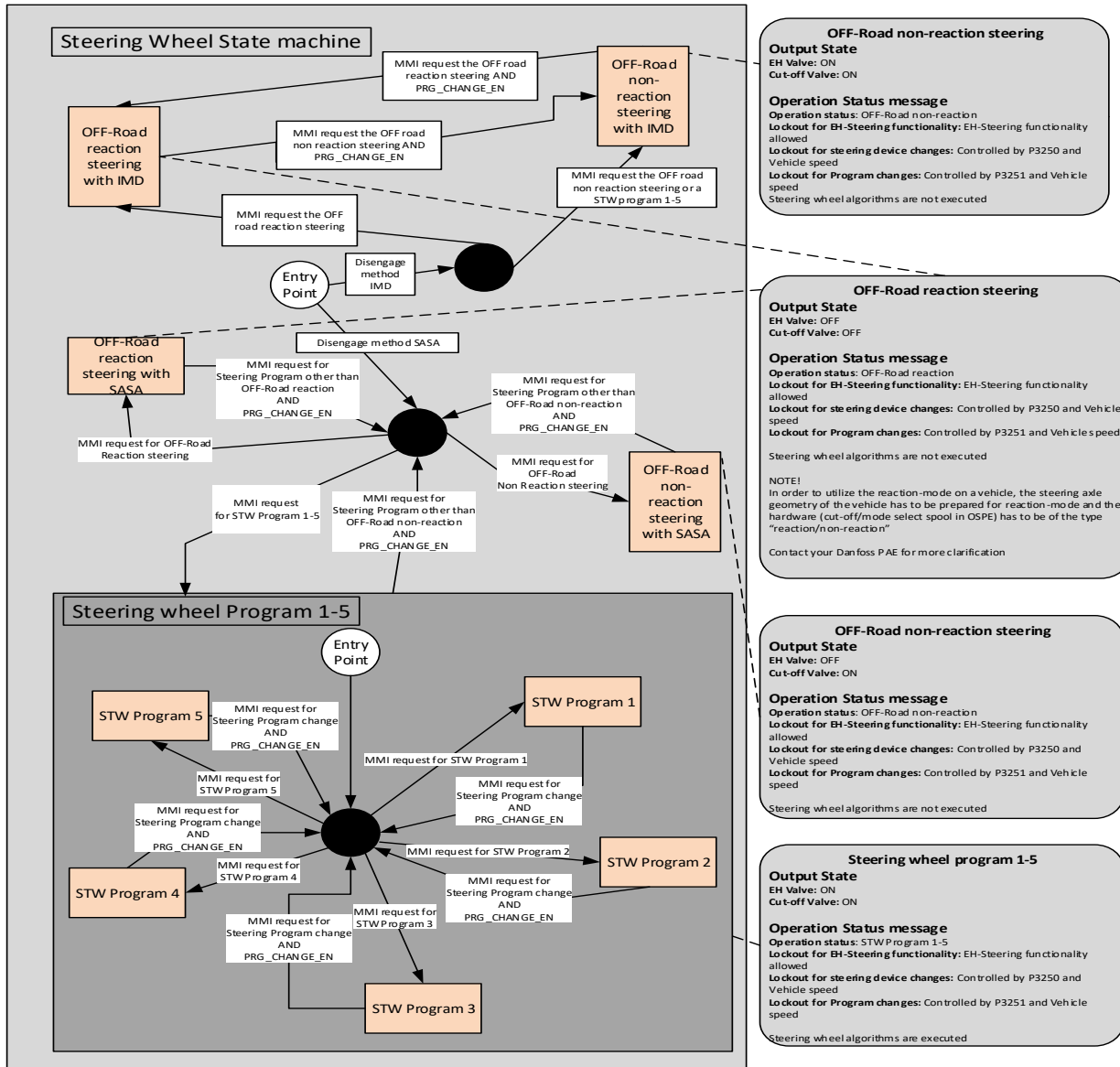

Figure 6



3.4 AUX STEERING STATE MACHINE

Figure shows the AUX steering device state machine. When the AUX device is configured to be a steering wheel, PVED-CLS offers 5 individually configurable steering programs. If the AUX device is configured to be a joystick, only 1 program is available. Find more information regarding AUX devices and the configuration in chapter 11.

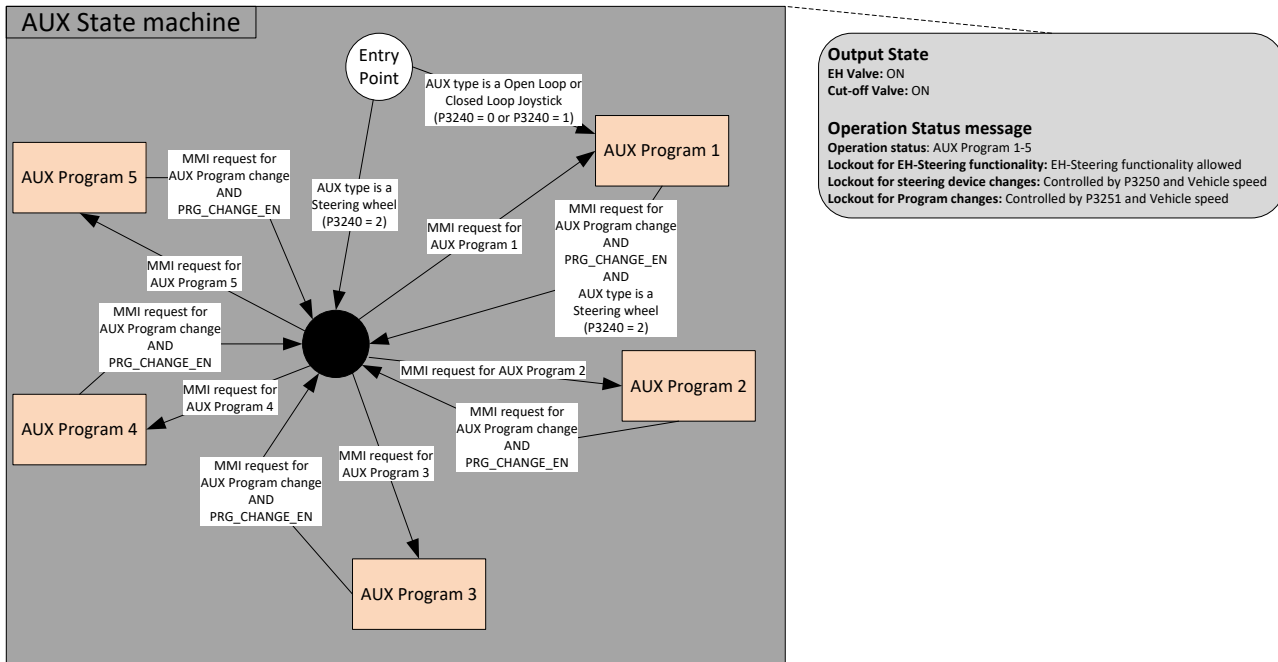

Figure 7

3.5 AUTO-GUIDANCE STEERING STATE MACHINE

When the Auto-guidance device is mapped and enabled, PVED-CLS offers configurable risk mitigation functions that will be shared by both GPS and GPS2, except for gain-parameters which are separate for GPS and GPS2. Find more information regarding auto-guidance devices and the configuration in chapter 12.

Below Figure , Figure and Figure 10 shows auto-guidance steering state machine. The auto-guidance state machine ensures that the selected auto-guidance controller follows the agreed protocol and to provide the auto-guidance controller with the required status information. State transitions are triggered by information from:

- The selected auto-guidance controllers
- MMI controller
- Steering wheel sensor (for OSPE, EHi-E and EHPS)
- Internal Monitoring Disengage (for EHi-H)
- AUX device

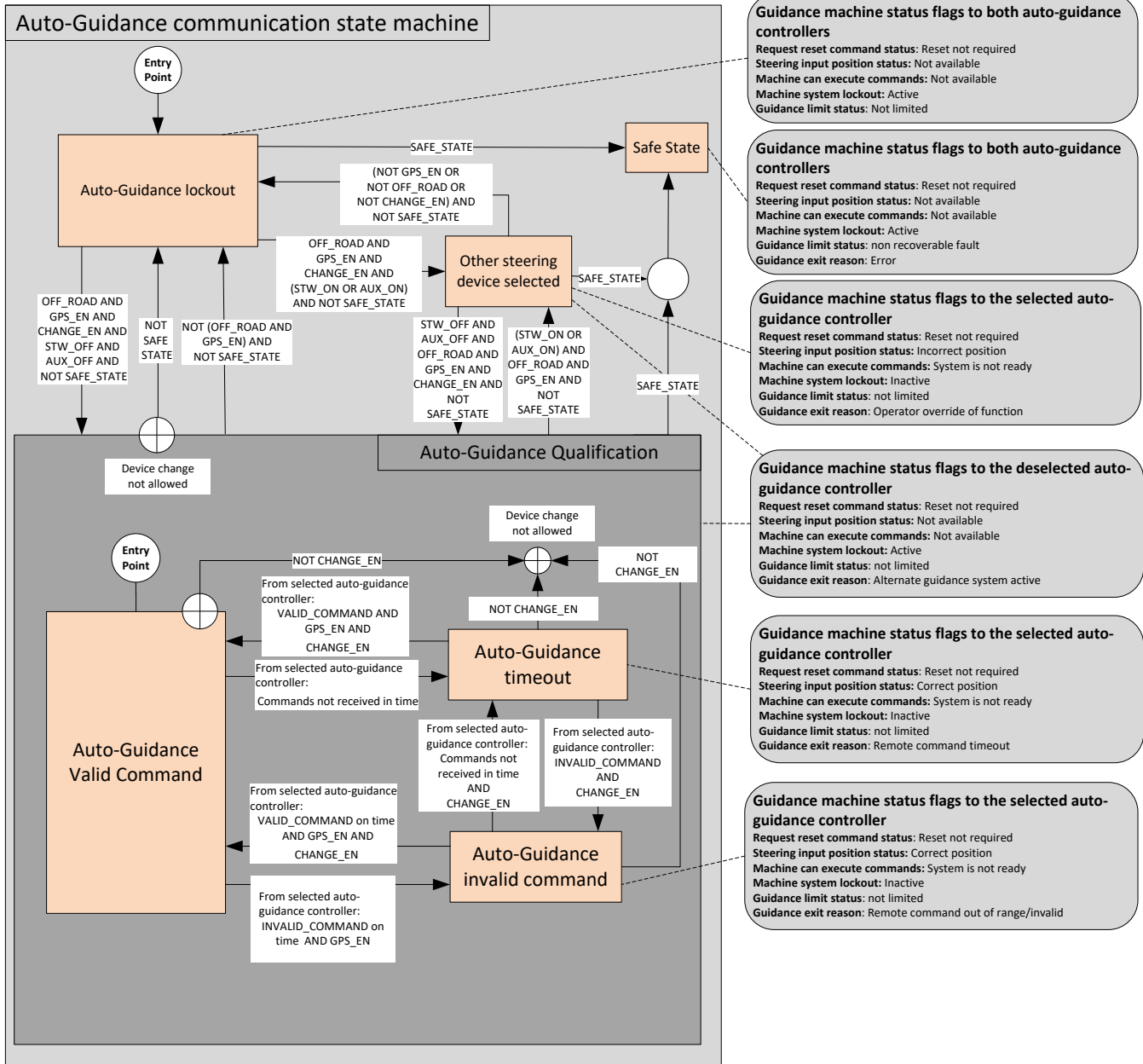
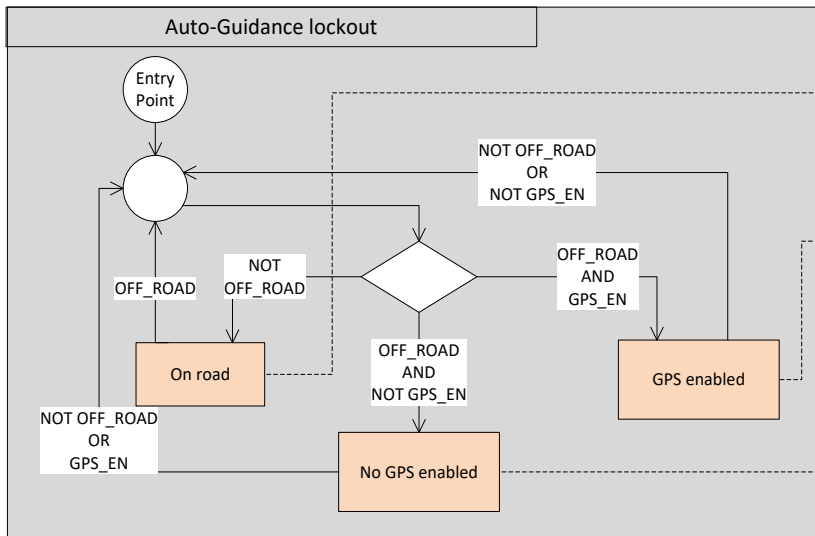

Figure 8



Guidance machine status flags to the both auto-guidance controllers
 Guidance exit reason: Operator override of function

Guidance machine status flags to the selected auto-guidance controller
 Guidance exit reason: Vehicle Speed Too high

Guidance machine status flags to the deselected auto-guidance controller
 Guidance exit reason: Alternate guidance system active

Guidance machine status flags to the both auto-guidance controllers
 Guidance exit reason: Alternate guidance system active

Figure 9

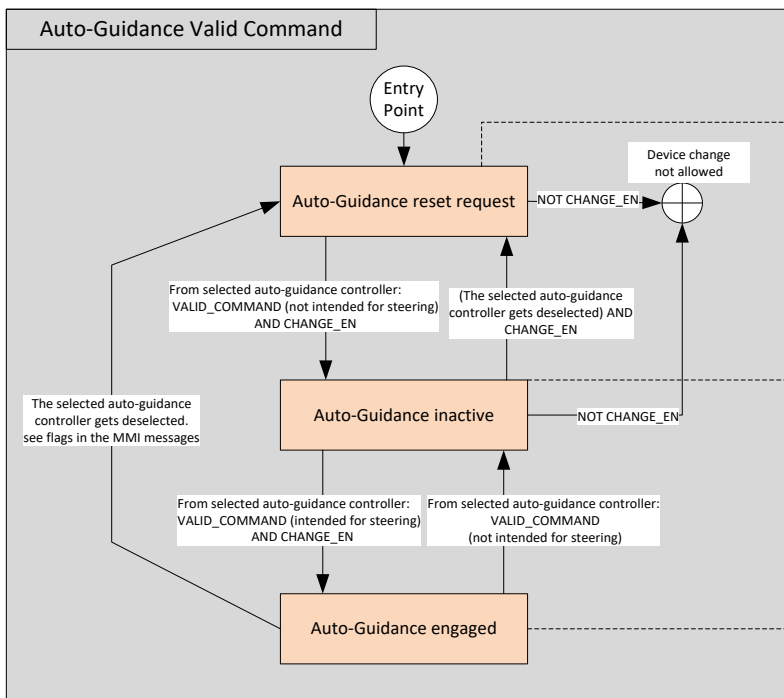

Guidance machine status flags to the selected auto-guidance controller
 Request reset command status: Reset required
 Steering input position status: Correct position
 Machine can execute commands: System is not ready
 Machine system lockout: Inactive
 Guidance limit status: Not limited
 Guidance exit reason: Normal Operation

Guidance machine status flags to the selected auto-guidance controller
 Request reset command status: Reset not required
 Steering input position status: Correct position
 Machine can execute commands: System is not ready
 Machine system lockout: Inactive
 Guidance limit status: Not limited
 Guidance exit reason: Normal Operation

Guidance machine status flags to the selected auto-guidance controller
 Request reset command status: Reset not required
 Steering input position status: Correct position
 Machine can execute commands: System is ready
 Machine system lockout: Inactive
 Guidance limit status: Provided by GPS control algorithm
 Guidance exit reason: Normal Operation

Figure 10



3.6 STATE TRANSITION REQUIREMENTS DESCRIPTION

3.6.1 Steering wheel related conditions

- **STW_ON** (Steering wheel in use):

The PVED-CLS detects the steering wheel to be in use when,

1. *|Steering wheel velocity| > threshold value for P3583 (STW in use - Velocity threshold)*
AND
|Steering wheel position difference| > threshold value for P3584 (STW in use - Angle threshold), where;

Where,

|Steering wheel position difference| = Current steering wheel position - Last detected steering wheel position at 0 RPM

2. **OR**

|Internal monitoring disengage| = Active

- **STW_OFF** (Steering wheel is not in use):

The PVED-CLS detects the steering wheel is not to be in use when,

|Steering wheel velocity| ≤ threshold value for P3583 (Steering wheel Velocity threshold)

Or

|Internal disengage monitoring| = Inactive

3.6.2 Auxiliary steering device (AUX) related conditions

- **AUX_OL_ON** (AUX open loop device in use):

The PVED-CLS detects the AUX open loop device to be in use when,

The AUX steering device is present in the system – P3239 set to 255

AND

The AUX steering device is enabled – see flags in the MMI messages in PVED-CLS communication protocol,

AND

1. *The AUX steering device is a mini-steering wheel – P3240 set to 2*

AND

|AUX mini-steering wheel velocity| > threshold value for P3646 (AUX mini-steering in use – Velocity threshold)

AND



$| \text{Mini-steering wheel position difference} | > \text{threshold value for P3719 (AUX mini-steering in use – Angle threshold)}$, where;

$| \text{Mini-steering wheel position difference} | = \text{Current mini-steering wheel position} - \text{Last detected mini-steering wheel position at 0 RPM (i.e. Last mini-steering wheel position when mini-steering wheel speed was below P3646)}$

OR

2. The AUX steering device is an open loop joystick -
P3240 set to 0, i.e. Open Loop Joystick

OR

P3240 set to 3, i.e. Analogue Joystick

OR

P3240 set to 20, i.e. Elobau joystick

AND

The AUX joystick reset has been done, i.e. the $| \text{requested AUX joystick flow command} |$ has been observed below the threshold value for P3647 (AUX joystick in use – Flow command threshold)

AND

The $| \text{Requested AUX joystick flow command} | \geq \text{threshold value for P3647 (AUX joystick in use – Flow command threshold)}$

- **AUX_CL_EN** (AUX closed loop joystick enabled):

The PVED-CLS detects the AUX closed loop joystick to be enabled when,
The AUX steering device is present in the system – P3239 set to 255

AND

The AUX steering device is enabled – see flags in the MMI messages in PVED-CLS communication protocol,

AND

The AUX steering device is a closed loop joystick – P3240 set to 1

AND

The closed loop joystick is enabled – see flags in the AUX messages in PVED-CLS communication protocol

- **AUX_CL_NO_ERR** (For being able to switch to AUX closed loop joystick when a higher priority steering device has been selected):

The $| \text{AUX steering device related closed loop error} | \leq \text{threshold value for P3732 (AUX joystick - Max closed loop error for engaging closed loop joystick steering)}$

- **AUX_DIS** (AUX device disabled):

The PVED-CLS detects the AUX device is disabled when,
The AUX steering device is not present in the system – P3239 set to 0

OR

The AUX steering device is disabled – see flags in the MMI messages in PVED-CLS communication protocol



- **AUX_OFF** (Condition for being able to switch from AUX to Auto-guidance if an AUX device is present in the system):

The PVED-CLS detects the AUX_OFF condition to be true when,
The AUX steering device is present in the system – P3239 set to 255

AND

1. *The AUX steering device is a mini-steering wheel – P3240 set to 2*

AND

|AUX mini-steering wheel velocity| ≤ threshold value for P3646 (AUX mini-steering in use – Velocity threshold)

OR

2. *The AUX steering device is an open loop joystick – P3240 set to 0, i.e. Open Loop Joystick*

OR

P3240 set to 3, i.e. Analogue Joystick

OR

P3240 set to 20, i.e. Elobau joystick

AND

The |Requested AUX joystick flow command| < threshold value for P3647 (AUX joystick in use – Flow command threshold)

OR

3. *The AUX steering device is a closed loop joystick – P3240 set to 1*

AND

The |AUX steering device related closed loop error| < threshold value for P3730 (AUX joystick - Max. CL steady state error threshold) for at least the time specified threshold value for P3731 (AUX joystick - Min time for CL steady state error threshold)

AND

The closed loop joystick is inactive – see flags in the AUX messages in PVED-CLS communication protocol

3.6.3 Auto-guidance related conditions

- **GPS_ON** (Auto-guidance is ready to become the active steering device):

Auto-guidance is ready to be engaged when,
An auto-guidance controller is present – P3237 (GPS) set to 255 and/or P3238 (GPS2) set to 255

AND

The corresponding auto-guidance controller is selected – see flags in the MMI messages in PVED-CLS communication protocol,

AND

The auto-guidance reset has been done - at least one curvature command from the selected auto-guidance-controller is marked as “not intended for steering” – see PVED-CLS Communication Protocol.

**AND**

The guidance system command message from the selected auto-guidance controller is available - The commands messages are received within the threshold specified by P3289 (Auto-guidance message monitoring – max time difference between two messages)

AND

Commands from the selected auto-guidance controller are marked as “intended for steering”

- **GPS_OFF** (auto-guidance inactive):

The auto-guidance is inactive when,

Neither GPS (P3237) nor GPS2 (P3238) is marked as being present (255) and selected by MMI – see flags in the MMI messages in PVED-CLS communication protocol

OR

Commands from the selected auto-guidance controller are not available or have exceeded the threshold specified by P3289 (Auto-guidance message monitoring – max time difference between two messages)

OR

The commands from the selected auto-guidance controller are not marked as “intended for steering”

OR

The commands from the selected auto-guidance controller are not marked as “invalid”

3.6.4 Vehicle speed dependent conditions

- **DEV_CHANGE_EN** (Steering device change allowed)

Steering device changes are allowed when,

$|Vehicle\ Speed| \leq threshold\ value\ for\ P3250$ (Max vehicle speed for selecting auto-guidance or AUX steering device)

- **PRG_CHANGE_EN** (Steering program change allowed)

Steering program change is allowed when,

$|Vehicle\ Speed| \leq threshold\ value\ for\ P3251$ (Max vehicle speed for program changes)

3.6.5 Other conditions

- **OFF_ROAD** (In Off-road steering mode)

The system is in the Normal Operation state and in the Off-road steering mode.

See additional info in chapter 7.7



4 Parameter configuration

The PVED-CLS contains more than 170 configurable parameters, which are divided into 15 sectors and 3 different PSAC user-levels (see tab “User” in the parameter list, paragraph 17.4), each having their own unlock code:

- Danfoss (access to all parameters)
- OEM
- Dealer

Sector name	Start address	End address	Sector size (bytes)	Access type	CRC/Checksum calculation end address	CRC/Checksum address	CRC/signature address	PSAC
Hydraulic Config	3072	3121	50	Read/Write	3097	3120	40	OEM
SEHS FDA	3122	3161	40		3134	3160	42	OEM
Valve Calibration Data	3162	3184	23		3171	3183	44	OEM, Dealer
CAN WAS Calibration Data	3185	3204	20		3196	3203	46	OEM, Dealer
Analog Sensor Calibration Data	3205	3236	32		3226	3235	48	OEM, Dealer
Peripherals Config	3237	3286	50		3253	3285	50	OEM
SEHS Protocol Data	3287	3350	64		3330	3349	52	OEM
Internal Monitoring	3351	3420	70		3394	3419	54	OEM
Vehicle Geometry	3421	3450	30		3429	3449	56	OEM, Dealer
GPS Config	3451	3520	70		3495	3519	58	OEM
STW Config	3521	3645	125		3585	3644	60	OEM
AUX Config	3646	3770	125		3742	3769	62	OEM
Production/Calibration Flag	3771	3790	20		3778	3789	-	OEM
Auto Calibration Config	3791	3863	73		3846	3862	64	OEM, Dealer
OEM Data	4212	4311	100		-	-	-	-

Table 3

Attention



Unlock codes, for the different user levels, are managed by Danfoss technical support team and can only be acquired by directly contacting the Danfoss technical support team!

Danfoss has developed a service tool (PLUS+1 SERVICE TOOL), and recommend the tool for:

- Changing parameters in the EEPROM
- Download of Software and bootloader
- Enable/disable diagnostic messages (status messages 1 - 7) on the CANbus
- Execute auto-calibration functionalities for WAS and Spool
- Controlling the spool manually for diagnostic purposes
- Extracting diagnostic data from the PVED-CLS (error history, temperature histograms etc.)



4.1 PARAMETER SETUP PROCEDURE – GOOD PRACTICE

When booting up a PVED-CLS for the very first time, it is good practice to follow this procedure:

1. Setup parameters in *Hydraulic Config*, *Peripherals Config*, *SEHS Communication Protocol* and *Vehicle Geometry*
2. Do WAS auto-calibration, Joystick auto-calibration and manual spool calibration (direct output control), and setup parameters in *Valve Calibration Data*, *CAN WAS Calibration Data/Analog Sensor Calibration Data* and *Production/Calibration Flag*
3. Setup parameters for steering device programs; *GPS Config*, *STW Config* and *AUX Config*
4. Setup parameters for *SEHS FDA* and *Internal monitoring*
5. Define parameters for *Auto-calibration Config*
6. Test Automatic spool calibration and verify safety setup of vehicle

For learning more of how the PLUS+1 SERVICE TOOL works, please go to the Danfoss Power Solution home page.

For using other tools than PLUS+1 SERVICE TOOL to manually changing parameters and updating sector- and signature CRC's in the EEPROM, please refer to the Danfoss document: PVED-CLS KWP2000 Protocol. Please see example in paragraph 17.5.5.



5 Installation

5.1 CONNECTOR INTERFACE

The PVED-CLS is only available with one connector variant: 12 pin Deutsch DT04-12PA-B016 connector

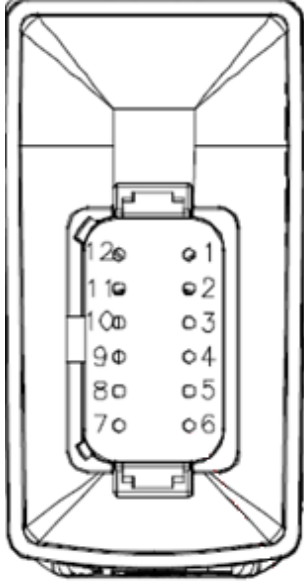

12 pin connector
DT04-12PA-B016

PVED-CLS			
Deutsch Connector			
Pinout			
1	AD2	7	Power ground -
2	AD3	8	Power supply +
3	Sensor power ground	9	CAN_L_MAIN
4	CAN_H_SAFETY	10	CAN_H_MAIN
5	CAN_L_SAFETY	11	5V sensor supply +
6	Digital output	12	AD1

Figure 11

Important

Deutsch assembly and installation guidelines must be followed for connector and harness. Accordingly, Danfoss recommends the use of lubricant (e.g. Nyogel 760G) on low-voltage electrical Connector contacts to further enhance the robustness against wear (e.g. fretting corrosion). Severe vibrations are critical and should be avoided as they can affect the lifetime of the connector.



5.2 PVED-CLS LED DIAGNOSTIC

The PVED-CLS is equipped with a LED (see Figure 12). The LED behavior will inform about the state of the PVED-CLS:

State	LED behavior
Main μ C in the bootloader mode or Main μ C detects the Safety μ C in the bootloader mode	Blinking between orange and green
PVED-CLS is performing the initialization or is in the on-road mode (electro-hydraulic steering disabled)	Orange
PVED-CLS is in the Safe State and information about the detected failure is available on CAN bus	Blinking orange
PVED-CLS is in the off-road steering mode (steering wheel, auto-guidance or other program) and the spool is in its neutral position or PVED-CLS is in the service mode	Green
The coils supply switch is turned on and the spool is outside its dead-band	Blinking green
PVED-CLS is in the Safe State, but no information about the detected failure is available on CAN bus (e.g. the address arbitration has been lost or the Main μ C built-in CAN controller failed to initialize or is unable to recover from the bus-off situation)	Red

Table 4

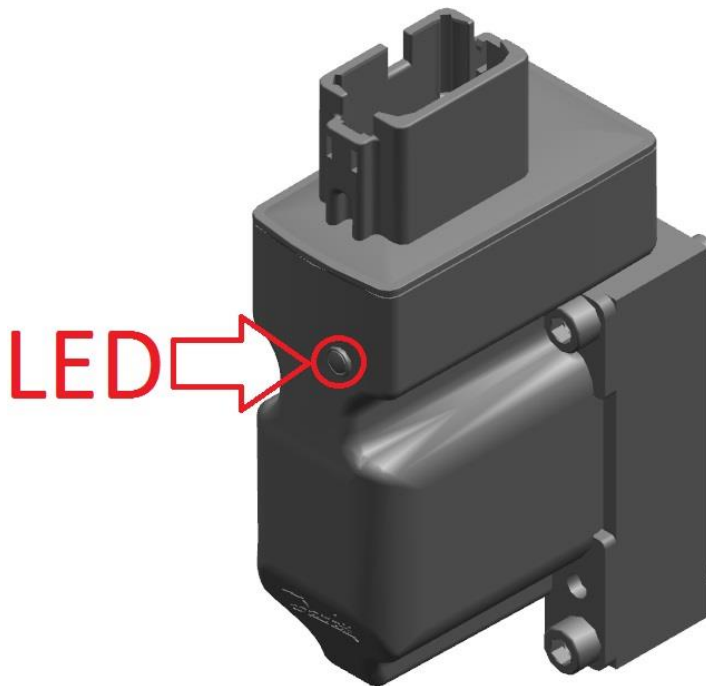

Figure 12

For more information regarding technical specification, please see Danfoss Document, PVED-CLS Technical Information.



6 Mapping a steering device/sensor

In a steering system comprised by a PVED-CLS and an OSPE, EHi-E or EHPS valve, following sensors are mandatory, therefore these sensors must be present on the CAN bus.

- SASAID
- Vehicle speed sensor
- MMI interface

In a steering system comprised by a PVED-CLS and an EHi-H valve, following sensors are mandatory, therefore these sensors must be present on the CAN bus.

- Vehicle speed sensor
- MMI interface

An EHi-H system cannot include a SASA sensor, meaning that fast-steer and EFU are not available.

Additionally, for auto-guidance, closed loop joystick steering, EFU & soft stop functions a wheel angle sensor needs to be configured in the system, see Section 8.1 and section 8.1.1. The wheel angle sensor sub-system can be CAN based or Analogue based. If it is analogue based, WAS may be connected to the analogue input pins of the PVED-CLS; AD1 and AD2 for analogue dual channel sensor sub-system and AD1 for single channel sensor sub-system.

In addition to the sensors and steering devices mentioned above, it is possible to map the cut-off valve (for OSPE/EHi-E/EHi-H systems), GPS (for auto-guidance steering), a road switch and a single AUX steering device (open loop- or closed loop joystick, or a mini-steering wheel).

Important

Disabling the wheel angle sensor eliminates the possibility of closed loop steering and some of the offered safety functions. For more details, please see the Danfoss document, PVED-CLS Safety Manual.

6.1.1 Valid Sensor Combinations

Following sensor configurations shall be followed

1. Only one analogue device/sensor may be present in the system i.e. either Analogue joystick or Analogue wheel angle sensor.
2. If no wheel angle sensor is present in the system then configurations shall be done according to section 8.1.1.
3. If Elobau Joystick is present in the system the configurations shall be done according to section 11.12.4

For mapping a steering device, the parameter controlling the sensor or steering device presence, needs to be enabled. Below are the parameters required for sensor configuration.



Name	Address	Data type	Unit	Description of parameter	User	Range		Danfoss default value	Safety critical parameters 'S'
						Min.	Max.		
Cut-off valve present	P3072	U8	-	Cut-off Valve Present/Not Present Valid Values: 0 (NOT PRESENT); 255 (PRESENT)	OEM	0	255	255	S
GPS present	P3237	U8	-	Auto-guidance controller present/Not Present Valid Values: 0 (NOT PRESENT); 255 (PRESENT)	OEM	0	255	255	
GPS2 present	P3238	U8	-	A second auto-guidance controller present/Not Present Valid Values: 0 (NOT PRESENT); 255 (PRESENT)	OEM	0	255	255	
AUX present	P3239	U8	-	AUX device Present/Not Present Valid Values: 0 (NOT PRESENT); 255 (PRESENT)	OEM	0	255	0	
Road switch present (connected to AD3)	P3241	U8	-	Specifies whether the road switch is or is not present, i.e. connected to the analogue input AD3 Valid Values: 0 (NOT PRESENT); 255 (PRESENT)	OEM	0	255	255	S
Redundant WAS present	P3245	U8	-	Redundant Wheel Angle Sensor Present/Not Present Valid Values: 0 (NOT PRESENT); 255 (PRESENT)	OEM	0	255	255	S
WAS interface	P3244	U8	-	Wheel Angle Sensor Interface Type Valid Values: 0 (ANALOGUE); 1 (CAN); 2 (NONE)	OEM	0	2	0	

Table 5

When mapping a steering device or sensor, the CAN source addresses (Table 6) and PGN's (Table 7) needs to be set up and checked for correctness. Find additional information about setting up the CAN communication in PVED-CLS communication protocol.

Name	Address	Data type	Unit	Description of parameter	User	Range		Danfoss default value	Safety critical parameters 'S'
						Min.	Max.		
GPS source address	P3292	U8	-	J1939 Source Address of the Auto-guidance controller	OEM	0	253	28	
GPS2 source address	P3293	U8	-	J1939 Source Address of a second Auto-guidance controller	OEM	0	253	29	
VSP source address	P3294	U8	-	J1939 Source Address of the vehicle speed sensor	OEM	0	253	251	
MMI source address	P3295	U8	-	J1939 Source Address of the MMI	OEM	0	253	252	
SASA sensor source address	P3296	U8	-	J1939 Source Address of the SASAID sensor	OEM	0	253	77	
PVED-CLS source address	P3297	U8	-	J1939 Source Address of the PVED (avoid using 127 and 241)	OEM	0	253	19, 90*	
Wheel angle sensor source address	P3298	U8	-	J1939 Source Address of the WAS	OEM	0	253	250	
AUX device (mini-steering wheel) source address	P3299	U8	-	J1939 Source Address of the AUX device (mini-steering wheel)	OEM	0	253	79	
AUX device (joystick) source address	P3300	U8	-	J1939 Source Address of the AUX device (joystick)	OEM	0	253	78	

Table 6

Warning



The value should not be the same in the Main- and Safety-controller!



Name	Address	Data type	Unit	Description of parameter	User	Range		Danfoss default value	Safety critical parameters 'S'
						Min.	Max.		
PGN offset to vehicle speed sensor message	P3318	U8	-	PGN offset to Vehicle speed message	OEM	0	255	64,65*	
PGN offset to steering wheel sensor messages	P3319	U8	-	PGN offset to SASA (steering wheel sensor) messages	OEM	0	255	16,17*	
PGN offset to wheel angle sensor messages	P3320	U8	-	PGN offset to Wheel Angle Sensor messages	OEM	0	255	18,19*	
PGN offset to AUX mini-steering wheel messages	P3321	U8	-	PGN offset to AUX device (mini steering wheel) messages	OEM	0	255	20,21*	
PGN offset to AUX joystick messages	P3322	U8	-	PGN offset to AUX device (joystick) messages	OEM	0	255	22,23*	
PGN offset to steering feedback message	P3323	U8	-	PGN offset to Steering Feedback Message	OEM	0	255	24	
PGN type for MMI message	P3324	U8	-	PGN type for MMI message: Proprietary A = 0; Proprietary B = 255	OEM	0	255	0	
PGN offset to MMI message	P3325	U8	-	PGN offset to MMI message , when using Proprietary B message format	OEM	0	255	66, 67*	
PGN for AUX Elobau joystick	P3329	U16	-	PGN for Aux Elobau Joystick- PGN' values for BJM1,BJM2,EJM1 and EJM2 are 64982,64984,64983 and 64985 respectively.	OEM	0	65535	64982	

Table 7

*Default Values for Safety controller

7 Hydraulic and peripherals Config

7.1 CUT-OFF VALVE

The cut-off valve is an essential part of OSPE, EHi-E and EHi-H valve sub-systems and an integral part in many of the safety functions included in the PVED-CLS.

The integrated cut-off valve spool (COV) can obtain two states, blocked and open. The COV is piloted by the cut-off solenoid valve, which is activated by applying power to the cut-off coil.

The COV spool will be in:

- blocked state, block the EH flow to the steering cylinder and block the hydraulic pilot supply pressure to the PVED-CLS pilot supply connection and instead connect the PVED-CLS pilot supply connection to tank.
- opened state, connect EH flow to the steering cylinder and lead hydraulic pilot pressure supply to the PVED-CLS pilot supply connection.

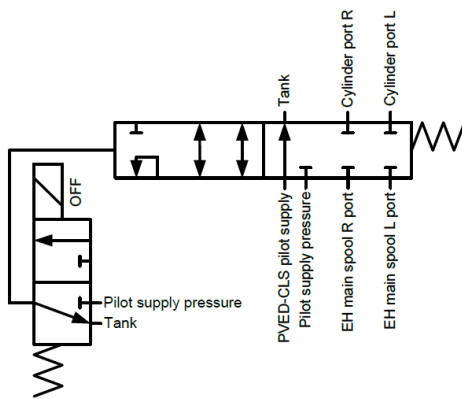

Simplified cut-off valve diagram. The cut-off solenoid valve is de-energized and thus the COV is in blocked state.

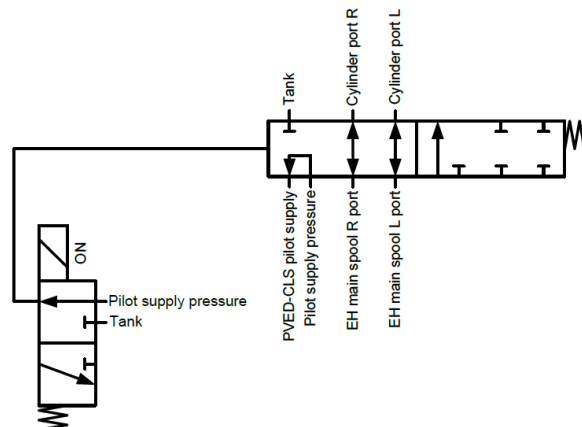

Simplified cut-off valve diagram. The cut-off solenoid valve is energized and thus the COV is in opened state.

Figure 13

Recommendation

If the PVED-CLS is mounted on a Danfoss OSPE, EHi-E or EHi-H valve, Danfoss insistently recommends that *P3072: Cut-off valve present* is set to 255 (*Present*).

Important

- For more details and wiring schematics, please refer to the PVED-CLS Safety Manual.
- If the PVED-CLS is mounted on an EHPS valve, *P3072: Cut-off valve present* must be set to 0 (*Not present*), as the EHPS valve does not have a cut-off valve. If *P3072: Cut-off valve present* is set to any other value than 0 (*Not present*), the PVED-CLS enters safe state.

7.1.1 Cut-off valve control



The PVED-CLS can control the cut-off solenoid valve, using two different current control algorithms, ON-OFF control mode and closed loop control mode. The control algorithm is selected using the parameter *P3073: Cut-off valve control mode*. Basically, both control algorithm is based on a PWM signal. Each of the control algorithms are described below.

ON-OFF control mode, i.e. *P3073: Cut-off valve control mode is set to 0*

This control algorithm will set the duty cycle of the PWM signal to 100%, when the PVED-CLS is activating the cut-off solenoid valve, this means that the power supply of the cut-off solenoid valve will be equal to the PVED-CLS power supply.

When the PVED-CLS is de-activating the cut-off solenoid valve, the duty cycle of the PWM signal will be set to 0%, Meaning that power supply of the cut-off solenoid valve will be equal to 0VDC

Closed loop control mode, i.e. *P3073: Cut-off valve control mode is set to 255*

This control algorithm utilizes three different current levels; PWM pre-load, pull current and hold current. Each level can be modified using the following parameters; *P3097: Cut-off valve PWM pre-load value*, *P3074: Cut-off valve CL pull current* and *P3076: Cut-off valve CL hold current*.

The closed loop control mode allows for a lower current consumption, by setting *P3076: Cut-off valve CL hold current* lower than *P3074: Cut-off valve CL pull current*.

The PWM pre-load, applies a PWM duty cycle, specified by *P3097: Cut-off valve PWM pre-load value*, for a period of 120ms, this ensures a fast pulling of the armature. After the 120ms period of PWM pre-load, the closed loop control algorithm is applied.

The cut-off solenoid valve needs a higher current to pull the armature, then to hold the armature, once it has been pulled to its open position. Therefore, the closed loop control algorithm, will start by applying *P3074: Cut-off valve CL pull current* as set-point for a 1880ms pull period. In order avoid unnecessary energy waste, the closed loop control algorithm, will then apply *P3076: Cut-off valve CL hold current* as set-point.

Therefore, it will take 2000ms, from the PVED-CLS activates the cut-off solenoid valve until it enters “power saving mode”. The timing of the closed loop control mode is further described in Figure 14.

Since the closed loop mode, will keep the current constant regardless of the battery voltage, it possible to use the same solenoids in all systems/machines.

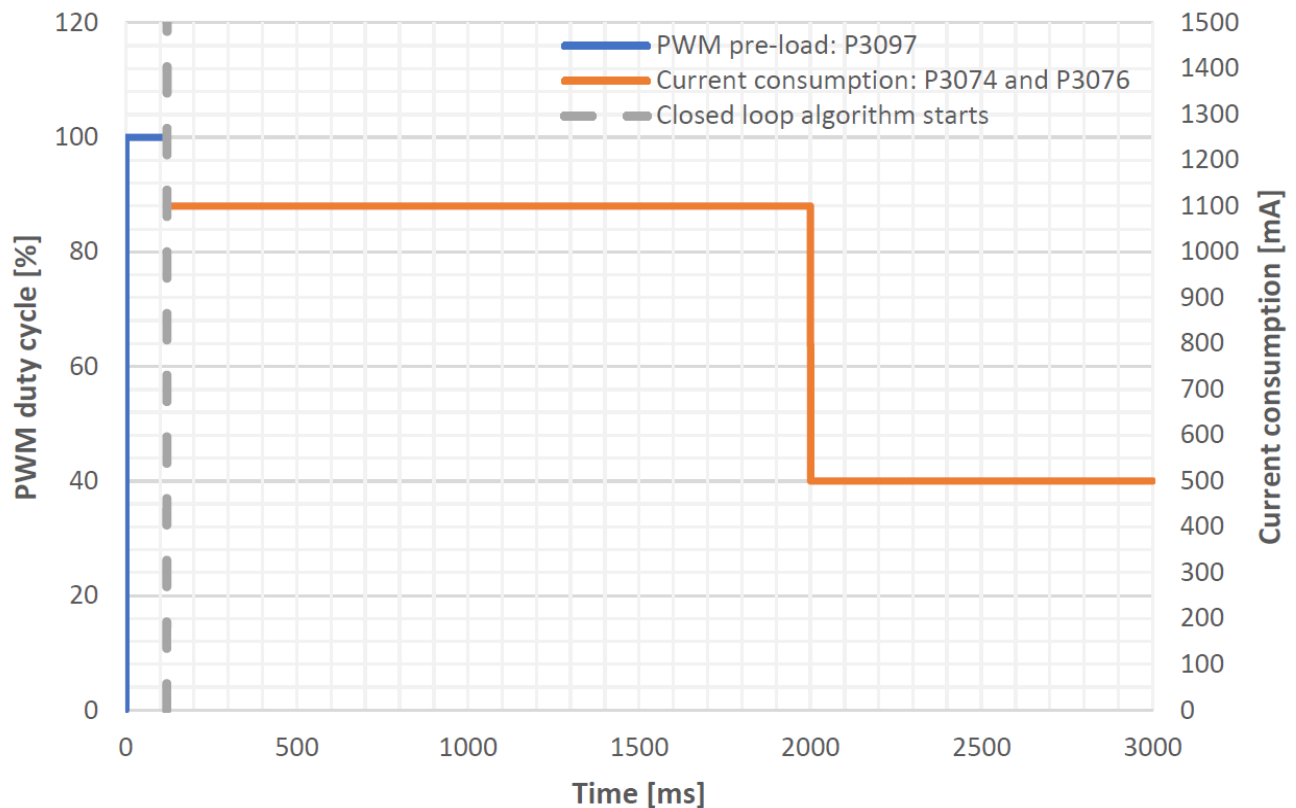

Figure 14

Recommendation

- Danfoss recommends using closed loop control mode, i.e. *P3073: Cut-off valve control mode* is set to 255 (*Closed loop control*).
- Danfoss recommends to use default values for *P3074: Cut-off valve CL pull current* and *P3076: Cut-off valve CL hold current*. Contact your local technical support at Danfoss Power Solutions if there is a need to change these parameters.
- Danfoss recommends setting *P3097: Cut-off valve PWM pre-load value* to 100 (100%), assuming solenoid has the same voltage rating as the battery voltage. If the solenoid does not have the same voltage rating as the battery voltage, the supply voltage to the solenoid controlled by *P3097: Cut-off PWM pre-load value*, which can be calculated as follows:

$$P3097 = \frac{\text{Solenoid valve rating}}{\text{Battery voltage}}$$

Example

Let battery voltage be 24 V and the solenoid voltage rating be 12 V, then *P3097: Cut-off valve PWM pre-load value* is found to be:

$$P3097 = \frac{12\text{ V}}{24\text{ V}} = 0,5$$



For this example, *P3097: Cut-off valve PWM pre-load value* must be set to 50 (50%), to avoid the PVED-CLS from triggering safe state due to overcurrent in the solenoid.

Important

There is no validation in the PVED-CLS that *P3074: Cut-off valve CL pull current* > *P3076: Cut-off valve CL hold current*.

Important

Danfoss recommends not to change the default values for P3074, P3076 and P3097. Contact your local technical support at Danfoss Power Solutions if there is a need to change these parameters.

Name	Address	Data type	Unit	Description of parameter	User	Range		Danfoss default value	Safety critical parameters 'S'
						Min.	Max.		
Cut-off valve present	P3072	U8	-	Cut-off Valve Present/Not Present Valid Values: 0 (NOT PRESENT); 255 (PRESENT)	OEM	0	255	255	S
Cut-off valve control mode	P3073	U8	-	Cut-off Valve control mode Close loop Control or ON-OFF control Valid Values: 0 (ON-OFF control); 255 (Closed loop control)	OEM	0	255	255	S
Cut-off valve CL pull current	P3074	U16	mAmp	Current required to activate Cut-off valve	OEM	100	2000	1100	S
Cut-off valve CL hold current	P3076	U16	mAmp	Current required to maintain Cut-off in ON state	OEM	100	2000	500	S
Cut-off valve PWM pre-load value	P3097	U8	%	Cut-off valve PWM pre-load value	OEM	0	100	100	

Table 8

7.1.2 Cut-off valve monitoring

The PVED-CLS continuously monitors the cut-off solenoid valve current level and if it exceeds the defined threshold of 2500mA, the PVED-CLS will de-energize the cut-off solenoid valve and enter safe state.

Furthermore, in off-road mode the PVED-CLS will monitor if the cut-off solenoid valve current level drops below half of the setting of *P3076: Cut-off valve CL hold current*. If the cut-off solenoid valve current is found below this level, the PVED-CLS will de-energize the cut-off solenoid valve and enter safe state.

Whenever switching from on-road mode to off-road mode, the PVED-CLS is performing diagnostics on the cut-off valve, this is called off-road safety check. If the off-road safety check is not successfully completed, a change to off-road mode will not be permitted and thus no electro-hydraulic steering will be available. Two different off-road safety checks can be executed, depending on the valve type.

7.1.2.1 Cut-off valve monitoring for OSPE, EHi-E

This safety check will be executed if *P3081: Valve type* is set to 0 (*OSPE, EHi-E*) and a mode change from on-road mode to off-road mode is requested.



The PVED-CLS checks that the EH-valve main spool can move to a set-point, inside the mechanical deadband, within the time specified by *P3078: Cut-off valve monitoring POST timeout*, when it is commanded to do so and the cut-off solenoid valve is turned on. Then the PVED-CLS checks that the EH-valve main spool cannot move when the cut-off solenoid valve is turned off, even though the EH-valve main spool is commanded to.

This check ensures that the cut-off valve can achieve the blocked state, when the cut-off solenoid valve is de-energized. By moving the EH-valve main spool in the mechanical deadband, it is ensured that no oil flow is sent to the steering

Important

Electro-hydraulic steering (Auto-guidance, Fast-steering and AUX-steering) will not be enabled before the PVED-CLS has passed this test.

Warning



By setting P3078: Cut-off valve monitoring POST timeout to 0 (Bypass off-road safety check), the Cut-off valve diagnostics are disabled.

Important

- *In most cases this test will be completed within 1 second, but if the oil has a very high viscosity, the time for completing this test will increase; hence Danfoss recommends a relatively high value for P3078 to ensure the PVED-CLS does not go into fail safe mode in cold conditions.*
- *If PVED-CLS is commanded to go to off-road mode before pump pressure is available, PVED-CLS will not be able to perform this self-test and hence fail after the specified timeout set by P3078.*

Name	Address	Data type	Unit	Description of parameter	User	Range		Danfoss default value	Safety critical parameters 'S'
						Min.	Max.		
Cut-off valve monitoring POST timeout	P3078	U16	x10mSec	Cut Off Valve Activation Timeout for COV Monitoring feature while entering Off Road state. INFO: Setting this parameter to 0 will bypass off-road safety check	OEM	0	1000	900	S

Table 9

7.1.2.2 Cut-off valve monitoring for EHi-H

This safety check will be executed if *P3081: Valve type* is set to 2 (*EHi-H*) and a mode change from on-road mode to off-road mode is requested. The cut off valve monitoring for EHi-H consists of IMD safety checks.

The PVED-CLS will set the EH-valve main spool set-point to a positive value inside the hydraulic deadband and alternately turn the cut-off solenoid valve on and off. Each time the COV solenoid valve is toggled, the time is measured



from it is toggled until the EH-valve main spool has been observed moving. The measured time is then evaluated against the value of *P3098: Safety-checks IMD – Rise time limits* and *P3099: Safety-checks IMD – Fall time limit*, for the rise time (cut-off solenoid valve turned on) and the fall time (cut-off solenoid valve turned off) respectively. Once the consecutive number of test passed, both rise times and fall times, is equal to the value of *P3100: Safety-checks IMD – Pass criteria*, the test is evaluated as passed and it will be repeated with a negative EH-valve main spool set-point. Once this test has passed as well, the PVED-CLS will be allowed to go into off-road mode.

If the consecutive number of test passed never reaches the value specified by P3100, the test will continue endlessly, or until either the safe state is triggered as mentioned above or on-road mode is requested.

If the fall time is observed longer than specified by *P3101: Safety-checks IMD – Maximum fall time*, the COV solenoid will be concluded as stuck open and the PVED-CLS will enter safe state. There is no limit on how long the rise time can be.

This check ensures that the cut-off valve can achieve the blocked state, when the cut-off solenoid valve is de-energized. By moving the EH-valve main spool in the mechanical deadband, it is ensured that no oil flow is send to the steering cylinders.

Name	Address	Data type	Unit	Description of parameter	User	Range		Danfoss default value	Safety critical parameters 'S'
						Min.	Max.		
Safety-checks IMD - Rise time limit	P3098	U8	x10mSec	Maximum rise time after switching ON cut-off valve for indicating EH-Spool is under control during safety-check.	OEM	10	100	30	S
Safety-checks IMD - Fall time limit	P3099	U8	x10mSec	Maximum fall time after switching OFF cut-off valve for indicating EH-Spool is under control during safety-check.	OEM	10	100	25	S
Safety-checks IMD - Pass criteria	P3100	U8	-	P3100 specifies how many safety-check cycles with successful EH-Spool control shall be executed before PVED-CLS passes the safety-checks.	OEM	2	8	2	S
Safety-checks IMD - Maximum fall time	P3101	U16	x10mSec	If the EH-Spool does not return to neutral within this timeout, the cut-off solenoid is concluded to be stuck open	OEM	100	1000	100	

Attention



IMD Safety check typically completes in 1.5 to 3 sec within the recommended viscosity operating range 12 to 75mm²/sec (Refer EHi TI). In number of cases, IMD Safety check may continue for extended period of time. Below are few instances:

1. **Engine OFF:** No hydraulic pressure available.
2. **Very Cold Oil / High Viscosity Oil:** Viscosity higher than 460 mm²/sec. (Refer EHi TI).
3. **Cold Oil (75 to 460 mm²/sec) :** IMD safety check may take longer than 3 sec.
4. **Cut off solenoid coil:** The coil may drop off the EHi Valve and stays attached to the connector.
5. **Contamination:** One or more spools could be blocked.
6. **Active Steering:** The operator continues steering wheel use during IMD safety check.

7.2 ROAD SWITCH

A road switch sub-system can be used to force the PVED-CLS and OSPE/EHi-E, PVED-CLS and EHi-H or PVED-CLS and EHPS valves into a state which is suitable for on-road operation while keeping the PVED-CLS operational. This state is called “safe on-road” state. PVED-CLS displays the Road-Switch status in the operation state message by the flag “Lock-out status for EH-steering functionality” – please refer to PVED-CLS communication protocol, for more details.



The PVED-CLS can remain powered in the safe on-road state. The OEM is responsible for building architecture suitable for achieving the correct SIL/PL/AgPL-level for shutting off the EH-steering flow for public road transportation.

Important

For more information regarding the requirements for the architecture and additional components, please see Danfoss document, PVED-CLS Safety Manual.

P3241 indicates if a road switch is connected to the PVED-CLS. The road switch functionality will only function correct if the following parameters are set correctly:

Parameter	Description	Default value			
		Main controller		Safety controller	
		EHPS	OSPE/EHi-E/ EHi-H	EHPS	OSPE/EHi-E/ EHi-H
P3072	Cut-off valve present. 0 = not present (EHPS) 225 = present (OSPE/EHi)	0	255	0	255
P3241	Road switch present(connected to AD3) 255 = present.	255	255	255	255
P3242	Road switch resistance check. 255 = enabled (EHPS) 0 = disabled (OSPE/EHi)	255	0	255	0

Table 10

Important

Not all combinations of these 3 parameters are valid. If an invalid condition is detected by PVED-CLS, it will enter safe state and notify about an invalid EEPROM configuration of the Peripherals sector. See truth table in Table 11.

P3072	Present	Not Present	Present	Not Present	Present	Not Present	Present	Not Present
P3241	Present	Present	Present	Present	Not Present	Not Present	Not Present	Not Present
P3242	Enabled	Enabled	Disabled	Disabled	Enabled	Enabled	Disabled	Disabled
Valid Combination	NO	YES	YES	YES	NO	NO	YES	YES

Table 11

Name	Address	Data type	Unit	Description of parameter	User	Range	Danfoss default value	Safety critical
------	---------	-----------	------	--------------------------	------	-------	-----------------------	-----------------



						Min.	Max.		
Cut-off valve present	P3072	U8	-	Cut-off Valve Present/Not Present Valid Values: 0 (NOT PRESENT); 255 (PRESENT)	OEM	0	255	255	S
Road switch present (connected to AD3)	P3241	U8	-	Specifies whether the road switch is or is not present, i.e. connected to the analogue input AD3 Valid Values: 0 (NOT PRESENT); 255 (PRESENT)	OEM	0	255	255	S
Road switch resistance check	P3242	U8	-	Road Switch Resistance check Enable/Disable Valid Values: 0 (DISABLE); 255 (ENABLE)	OEM	0	255	0	S

Table 12

7.2.1.1 Road switch monitoring

The PVED-CLS will perform a cut-off solenoid valve connection test when PVED-CLS is in safe on-road state. Safe state will be triggered if the cut-off solenoid valve is found connected.

When PVED-CLS is in Safe on-road state, this function slowly increases the duty-cycle on the cut-off output. If the current raises above the parameter threshold, specified by P3243, the PVED-CLS goes to safe, because it has detected that the Cut-off coil was not disconnected on the transition to Safe on-road thus reports a relay switch failure.

Name	Address	Data type	Unit	Description of parameter	User	Range		Danfoss default value	Safety critical parameters 'S'
						Min.	Max.		
Max COV connection test current	P3243	U8	mAmp	The max. Current allowed to be observed during the cut-off solenoid valve connection test.	OEM	10	255	100	S

Table 13

7.3 EH STEERING DISENGAGE METHOD

When the steering wheel is activated, the PVED-CLS has two different options of detecting activation and consequently disengaging AUX / Auto guidance. First method is for the OSPE, EHi-E (also defined as EHi-E, refer TI of EHi) and EHPS system with the SASA sensor. The second method is for the EHi-H system without SASA sensor. EH steering disengage in an EHi-H system is achieved by means of IMD function which can detect if the steering wheel is activated; this is hydraulic disengage.

The disengage method can be set with P3254. It is only valid to select IMD when the valve type is set to EHi-H.

Name	Address	Data type	Unit	Description of parameter	User	Range		Danfoss default value	Safety critical parameters 'S'
						Min.	Max.		
EH-Steering Disengage Method	P3254	U8	-	Disengage method Valid values: 0 (SASA); 1 (IMD)	OEM	0	255	0	S



7.3.1.1 Internal monitoring disengage (IMD)

When the IMD disengage method is selected, the PVED-CLS will continuously monitor the main spool and disengage EH steering when main spool is forced to neutral by hydraulic override. (For details on hydraulic override, refer Safety manual). In case the requested spool position is $< \pm 0.4(\text{mm})$ for longer than IMD – EH-Spool in neutral confidence limit (P3587), spool position will be fixed to either 0.4(mm) or -0.4(mm), depending on the previous steering direction.

When the steering wheel is being turned the actual spool position will drop below $\pm 0.4(\text{mm})$. When the actual spool position is within the threshold defined by Absolute spool neutral threshold range (P3090), and stays there for longer than IMD - EH-Steering disengage confidence limit (P3586), the IMD will disengage the EH steering.

When the EH spool position is forced to neutral, the closed loop control will try to correct the position to avoid the overshoots by changing the gain in the regulation. (For details on the P3588 and P3589, refer Safety Manual).

Name	Address	Data type	Unit	Description of parameter	User	Range		Danfoss default value	Safety critical parameters 'S'
						Min.	Max.		
IMD - EH-Steering disengage confidence limit	P3586	U8	x10ms	Timeout value to declare steering movements to be active if EH-Spool stays within the limit specified by P3090.	OEM	0	255	30	S
IMD- EH-Spool in neutral confidence limit	P3587	U8	x10ms	If EH-Spool stays within the threshold specified by P3090 for the timeout value specified by P3590, IMD overrules EH-Steering algorithms and takes over spool control to evaluate spool position.	OEM	0	255	15	S
IMD - Dynamic SVC integral limit	P3588	U8	-	Dynamic SVC integral limit to use while EH-Spool is close to neutral	OEM	0	255	25	S
IMD - Integral gain	P3589	U16	0,1	Dynamic SVC integral gain to use while EH-Spool is close to neutral.	OEM	0	65535	225	S
IMD - Threshold	P3591	U16	x10u Meter	Steering activation spool threshold is close to neutral	OEM	10	25	15	S

Attention



How to verify the correct operation of IMD, follow below steps:

1. Check the status message 1 sent by CLS Main and Safety controller, for the requested spool position and actual spool position. As mentioned above, if the requested spool position is $< 0.4\text{mm}$, then the actual spool position is either fixed to $+0.4\text{mm}$ or -0.4mm (based on the previous EH-steering direction). When the steering wheel is manually being turned, the actual spool position is forced to neutral. If the spool fails to arrive at neutral even after the turning the steering wheel, then hydraulic over ride is failing to perform.
2. Check the hydraulic connections (for EHi hydraulic schematics refer EHi TI). There must not be any missing connections in the EHi configuration.
3. Check the steering unit pressure, P-T bar in neutral to be below 14 bar (refer service manual of EHi). If higher than 14 bar IMD may disable EH steering operation.

Important

The PVED-CLS is dedicated for IMD: It has built in check valves between pilot ends of the EH spool to the PE pilot supply. In this way, its ensured there will be no hydraulic pressure on either end of the spool when the cut off spool is in safe state, because the pilot supply is connected to tank. For IMD operation use only PVED-CLS including check valves.



7.4 VALVE CAPACITY

The valve capacity parameter (P3088) must be set to the corresponding EH flow size.

P3088 indicates the EH-spool's (either in the OSPE, EHi-E, EHi-H or EHPS) maximum output flow, given in liters per minute. The nominal value for the EH-spool's maximum output flow can be found on the OEM's customer drawing.

Depending on the standby pressure for the steering system, the actual maximum output flow will deviate. As default, the nominal value will in most cases give a very acceptable steering performance in fast-steering mode but for fine-tuning of P3088, please contact your local Danfoss representative.

Following example is valid for OSPE with internal priority valve with 7 bar spring and 1.0 mm dynamic orifice and @ 60 l/min pump flow. For OSPE without internal priority valve, the curves are valid in combination with external priority valve OLS 80, P/N:152B8269 @ 60 l/min pump flow:

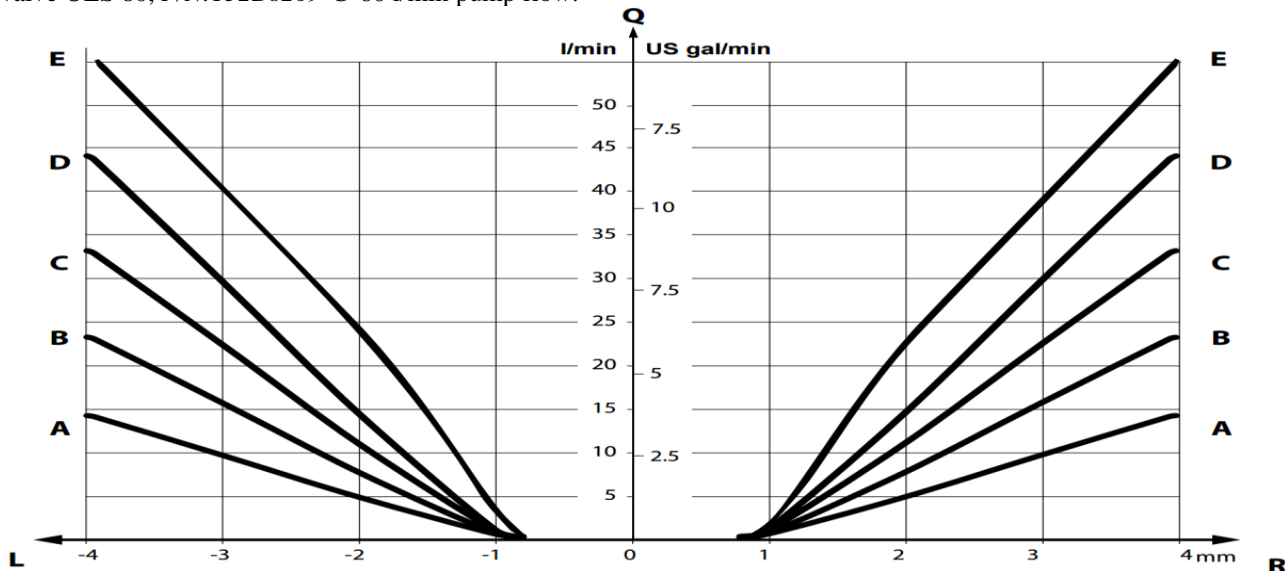

Figure 15 (a)

- A: valid for spools for nominal cylinder flow CQ = 12 l/min
- B: valid for spools for nominal cylinder flow CQ = 20 l/min
- C: valid for spools for nominal cylinder flow CQ = 30 l/min
- D: valid for spools for nominal cylinder flow CQ = 40 l/min
- E: valid for spools for nominal cylinder flow CQ = 50 l/min

For EHPS following spools are available

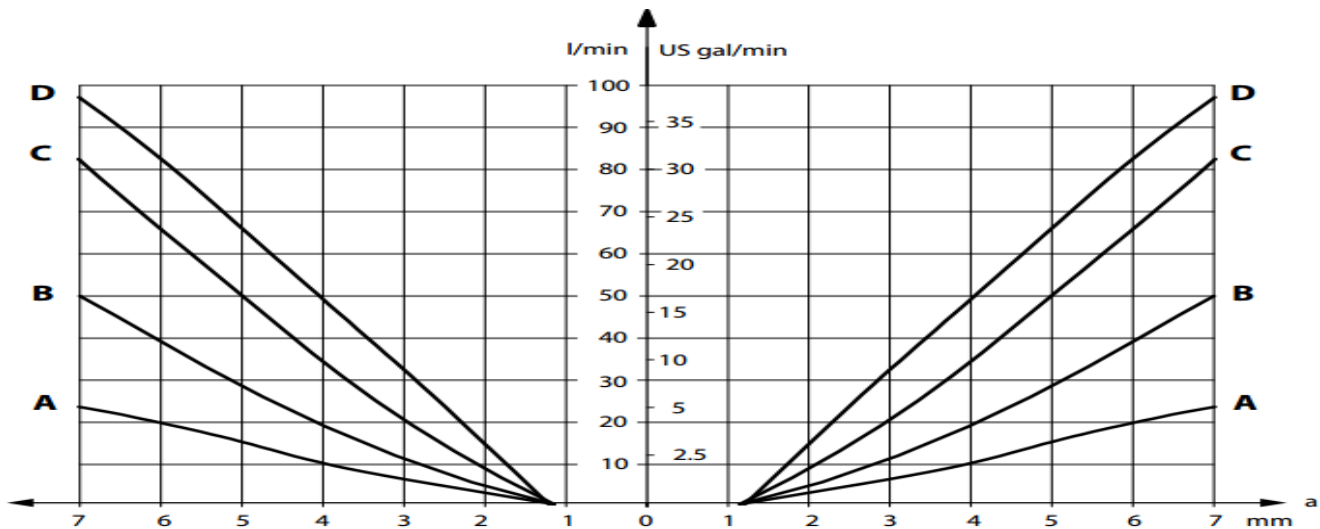

Figure 15 (b)

- A: valid for spools for nominal cylinder flow CQ = 20 l/min
- B: valid for spools for nominal cylinder flow CQ = 40 l/min
- C: valid for spools for nominal cylinder flow CQ = 60 l/min
- D: valid for spools for nominal cylinder flow CQ = 80 l/min

Furthermore, if the PVED-CLS is mounted on a EHPS, then the flow direction needs to be inverted (P3080 set to 255) and the turns lock-to-lock on the steering wheel (when the electronics are not activated, hence pure hydraulic steering) needs to be entered in P3082 (resolution is 0.01 turns).

7.5 LVDT COMPENSATION AND SPOOL THRESHOLD AT BOOT-UP

7.5.1.1 LVDT compensation

The LVDT feedback signal, which is the EH-spool feedback to the PVED-CLS, can be compensated for temperature changes by setting P3089 to 255.

By Default, *LVDT Offset compensation is Enabled* i.e. P3089 is set to 255.

Important

Danfoss recommends to keep the LVDT compensation always active. LVDT compensation should only be disabled when performing diagnostic troubleshooting on the PVED-CLS.

7.5.1.2 Spool threshold at boot-up

When power is applied to the PVED-CLS, the spool needs to be in neutral. The +/- tolerance, given in $\times 10\mu\text{m}$, is controlled by P3090. If the spool is outside this threshold during boot-up and the PVED-CLS is mounted on an OSPE/EHi, the PVED-CLS will go into safe state. If the PVED-CLS is mounted on an EHPS, further checks are done to see if the spool has moved outside the dead-band, a confidence counter level has to be reached before PVED-CLS will go into safe state.

Important

Danfoss recommends to keep the parameter P3090 at default value (P3090 set to 25) unless problems/failures occurs with the default value, this should not be changed.



Name	Address	Data type	Unit	Description of parameter	User	Range		Danfoss default value	Safety critical parameters 'S'
						Min.	Max.		
LVDT offset compensation Enable/Disable	P3089	U8	-	LVDT Offset compensation Enable/Disable Valid Values: 0 (DISABLE); 255 (ENABLE)	OEM	0	255	255	
Absolute spool neutral threshold range	P3090	U8	10 um	Absolute value of Spool neutral threshold range at boot-up	OEM	0	200	25	

Table 14

7.6 ANALOGUE INTERFACE

7.6.1.1 AD low-pass filter

A configurable (by P3249) first-order low-pass filter is applied before the AD sampling.

Name	Address	Data type	Unit	Description of parameter	User	Range		Danfoss default value	Safety critical parameters 'S'
						Min.	Max.		
AD low pass filter cut-off frequency	P3249	U8	dHz	5V sensor, AD1 and AD2 filter cut-off frequency Resolution: 1 dHz = 0.1 Hz	OEM	5	200	100	

Table 15

Important

The AD3 input has a fixed 20Hz low-pass filter and is not affected by P3249!

7.6.1.2 Analogue input drift compensation

A radiometric compensation algorithm has been implemented to ensure robustness of the analogue sensor signal either from the wheel angle sensor(s) or from an analogue joystick, even when the 5VDC sensor supply drifts between 4.65 – 5.35VDC. Checks are done between the calibrated sensor supplies (P3217 and P3219) and the actual 5VDC sensor supply.

Danfoss recommends to activate the drift compensation for analogue sensors without built-in compensation.

The objective is to compensate for any drift in the analogue sensor values as a result of aging or temperature of the electronic circuits.

To select compensation for the primary analogue sensor and, if present, the redundant analogue sensor, set the parameter value for P3246 and P3247 both to 255.

If no compensation is needed set parameter P3246 and P3247 both to 0.

Name	Address	Data type	Unit	Description of parameter	User	Range	Danfoss default value	Safety critical parameters 'S'
------	---------	-----------	------	--------------------------	------	-------	-----------------------	--------------------------------



						Min.	Max.		
5V sensor supply for primary analogue sensor during calibration	P3217	U16	mVolts	Measured Supply voltage during calibration of the primary analogue sensor	OEM, Dealer	4650	5350	5000	
5V sensor supply for redundant analogue sensor during calibration	P3219	U16	mVolts	Measured Supply voltage during calibration of the redundant analogue sensor	OEM, Dealer	4650	5350	5000	
Voltage compensation for Primary analogue sensor	P3246	U8	-	Supply voltage compensation Enable/Disable for processing primary Analogue sensor signal Valid Values: 0 (DISABLE); 255 (ENABLE)	OEM	0	255	255	
Voltage compensation for Redundant analogue sensor	P3247	U8	-	Supply voltage compensation Enable/Disable for processing redundant analogue sensor signal Valid Values: 0 (DISABLE); 255 (ENABLE)	OEM	0	255	255	

Table 16

7.6.1.3 Sensor supply test

With P3248, the internal 5V supply on the PVED-CLS’ pin 11 can be enabled/disabled. This parameter is only intended for testing purpose, and should be kept at Enable (P3248 set to 0) all time.

Important

P3248 set to 1 will shut down the sensor supply but not the monitoring of it. So if it is disabled (i.e. P3248 set to 1), an external 5V supply has to be connected to PVED-CLS sensor supply pin (pin 11) else PVED-CLS will go to safe state.

Important

If an internal 5V is chosen in the PVED-CLS and a WAS of the potentiometer-type, remember to setup the analogue channel compensation parameters too (P3246 and P3247).

Name	Address	Data type	Unit	Description of parameter	User	Range		Danfoss default value	Safety critical parameters ‘S’
						Min.	Max.		
Generation of 5V sensor supply voltage (Deutsch connector pin 11)	P3248	U8	-	Sensor Supply Test. Disable/enable the internal 5V supply on the PVED-CLS’ pin 11. Valid Values: 0 (Enable); 1 (Disable) Note: Should be kept at Enable (P3248 set to 0) all time	OEM	0	1	0	

Table 17

7.7 STEERING DEVICE AND PROGRAM CHANGES

Different steering devices with different programs can be used together with the PVED-CLS. The PVED-CLS will lock a steering device, when a vehicle speed threshold of P3250 is exceeded (i.e. the PVED-CLS will ignore any steering device change messages of lower priority, if the vehicle is traveling faster than the value in P3250). If any steering device change messages of a higher priority than current steering device are sent, the PVED-CLS will change to that steering device.

The priority order, for steering devices is as follows:

1. Steering wheel (STW)
2. Auxiliary steering device (AUX)
3. Auto-guidance



Below the threshold, specified by P3250, it is allowed to switch between any steering device programs, no matter the priority. Above this threshold, steering device program cannot be switched to the one with lower priority, only a steering device with a higher priority is allowed.

The complete PVED-CLS Steering mode selection state machine is shown in chapter 3.2. Similar to the steering device lock, the PVED-CLS will lock a steering program (AUX or STW), when a vehicle speed threshold of P3251 is exceeded (i.e. the PVED-CLS will ignore any steering program change messages, if the vehicle is traveling faster than the value in P3251).

The state machines for Steering wheel, AUX and Auto-guidance steering device are shown in chapter 3.3, 3.4 and 3.5.

Name	Address	Data type	Unit	Description of parameter	User	Range		Danfoss default value	Safety critical parameters 'S'
						Min.	Max.		
Max vehicle speed for engaging auto-guidance or AUX steering device	P3250	U8	km/h	Max vehicle speed at which a lower priority steering device can be engaged	OEM	0	100	15	S
Max vehicle speed for steering program changes	P3251	U8	km/h	Max vehicle speed at which a steering program for the selected device can be changed	OEM	0	100	15	S

Table 18

7.8 VEHICLE SPEED SETUP

When driving in auto-guidance mode at a low speed, the spool movement will be disabled, for safety reasons, when the vehicle speed goes below the threshold specified P3252. The resolution is $1 \times 10 \text{m/h} = 10 \text{ meter pr. hour}$.

Important

This parameter is valid for all programs (i.e. AUX, Auto-guidance and Fast-steering).

P3253 indicates at which vehicle speed, the PVED-CLS should go into safe state, if this vehicle speed is exceeded during EH-steering.

Important

If the PVED-CLS is in Safe ON-Road mode, the PVED-CLS will not go into safe state (SVB and cut-off valve are already de-energized)!

Name	Address	Data type	Unit	Description of parameter	User	Range		Danfoss default value	Safety critical parameters 'S'
						Min.	Max.		
Lower vehicle speed auto-guidance suspend threshold	P3252	U8	x10 m/h	Minimum vehicle speed below which spool movement is disabled when Auto-guidance steering is engaged. Resolution: $1 \cdot 10 \text{ m/h} = 10 \text{ meter pr. hour}$	OEM	0	200	50	S
Safe state vehicle speed threshold	P3253	U8	km/h	The vehicle speed at which the PVED-CLS shall enter the safe state	OEM	5	100	25	S

Table 19

For more details on P3252 and P3253, please refer Safety manual.

7.9 VEHICLE GEOMETRY

P3421 indicates the steering geometry of the vehicle; Ackermann/two wheel steering geometry or articulated steering geometry.

For Ackermann-steering geometry (front wheel- or back-wheel-steering only), P3421 is set to 1. For articulated steering geometry, P3421 is set to 2.

P3422 and P3424 indicate the wheel base parameters, given in mm. If Ackermann steering geometry has been selected (P3421 set to 1) only P3422 has to be set, which is the length between the front axle and the rear axle. If articulated steering geometry has been selected (P3421 set to 2) then both P3422 and P3424 need to be set. Now P3422 indicates the length between the front axle and the articulating point and P3424 indicates the length between the articulating point and the rear axle.

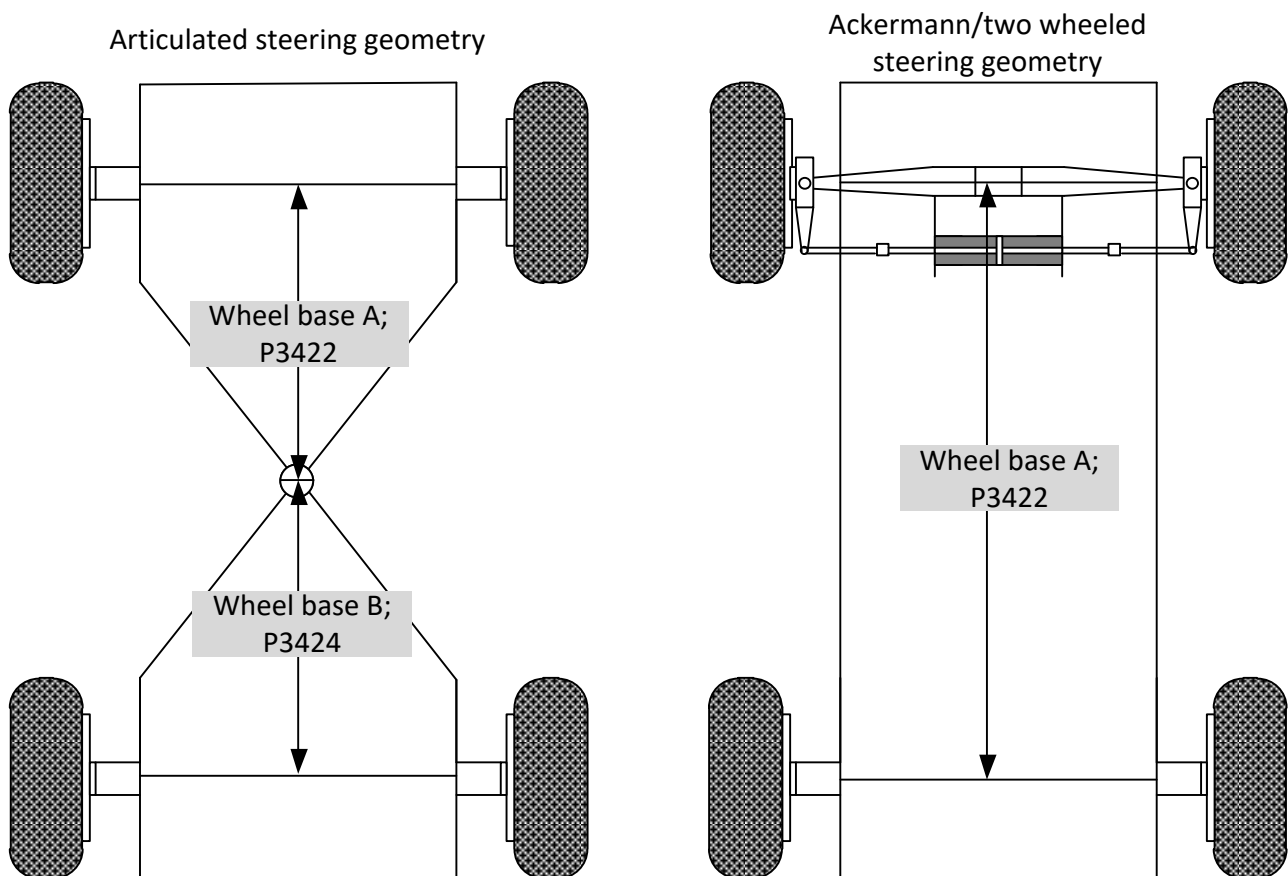

Figure 16

For Ackermann, P3426 and P3428 indicate the maximum steering angle (left and right) for the center point, in center of the front axle, given in degrees, each with reference to straight ahead (see Figure).

For Ackermann model, the algorithm uses the center point of the front axle. The maximum steer angles can be determined by steering the vehicle into the smallest circle possible (steering to end stop). From the radius acquired (measured from



the center of the rear axle) and the wheel base knowledge, the angle Θ can be calculated, which is equal to P3426 when steering in a circle to the left and P3428 when steering in a circle to the right.

$$\theta = \tan^{-1}\left(\frac{WB}{R}\right)$$

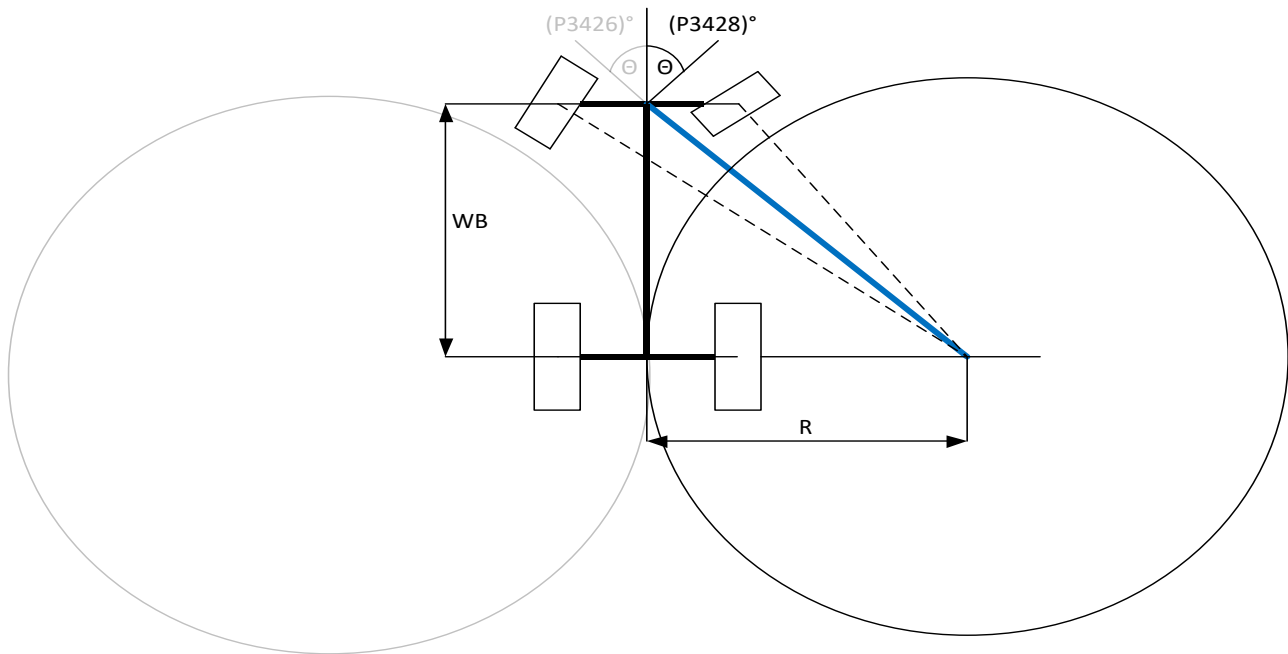

Figure 17

For most vehicles, the max steering angle, left and right, would be the same (as the vehicle has the same turning radius, left and right). For those vehicles, the value for parameters P3426 and P3428 will be the same. But some vehicles have different turning radii left versus right, hence the exercise of steering into the smallest circle possible must be done to both left and right, for obtaining the two Θ -angles.

For an articulated vehicle, the maximum steer angle (left and right) is the maximum steer angle from the joint-sensor, given in degrees, each with reference to straight ahead. If two sets of joint angle sensors are mounted, then use the values from the primary joint angle sensor.

Important

For articulated model, if steering sensor is placed in steering cylinder, only consider the angle in the articulation point!

Name	Address	Data type	Unit	Description of parameter	User	Range		Danfoss default value	Safety critical parameters 'S'
						Min.	Max.		
Vehicle steering type	P3421	U8	-	Vehicle steering type Valid Values: 1 (TWO WHEEL/ACKERMANN); 2 (ARTICULATED)	OEM, Dealer	1	2	1	
Wheel base A	P3422	U16	mm	Distance between the axles (front or rear wheel steered vehicle only) or between an axle and the articulation point (articulated vehicles only)	OEM, Dealer	1000	10000	4000	



Wheel base B	P3424	U16	mm	Distance between the other axle and the articulation point (articulated vehicles only)	OEM, Dealer	1000	10000	4000	
Maximum steer angle, left	P3426	U16	Deg	Maximum steer angle to left side Note: Writing values >89 will force to use automatic adjusted maximum steer angle, Left-value on WAS calibration	OEM, Dealer	0	65535	35	
Maximum steer angle, right	P3428	U16	Deg	Maximum steer angle to right side Note: Writing values >89 will force to use automatic adjusted maximum steer angle, Right-value on WAS calibration	OEM, Dealer	0	65535	35	

Table 20

7.10 SETUP A STEERING DEVICE

When an additional sensor/steering device has been mapped, make sure that all common parameter are setup accordingly, e.g. if a redundant WAS is mapped (P3245 set to 255), the following parameters needs to checked and configured:

Name	Address	Data type	Unit	Description of parameter	User	Range		Danfoss default value	Safety critical parameters 'S'
						Min.	Max.		
Redundant analogue sensor max left position	P3211	U16	mVolts	Redundant analogue sensor voltage output for leftmost position	OEM	0	6000	500	
Redundant analogue sensor max right position	P3213	U16	mVolts	Redundant analogue sensor voltage output for rightmost position	OEM	0	6000	4500	
Redundant analogue sensor neutral position	P3215	U16	mVolts	Redundant analogue sensor voltage output for neutral position	OEM	0	6000	2500	
5V sensor supply for redundant analogue sensor during calibration	P3219	U16	mVolts	Measured Supply voltage during calibration of the redundant analogue sensor	OEM	4650	5350	5000	
Voltage compensation for Redundant analogue sensor	P3247	U8	-	Supply voltage compensation Enable/Disable for processing redundant analogue sensor signal Valid Values: 0 (DISABLE); 255 (ENABLE)	OEM	0	255	255	

Table 21

Additionally, any additional applied sensors also needs to be calibrated.

For more detailed description on how to setup sensors and steering devices and changing parameters, please see the Danfoss documents, PVED-CLS Communication Protocol and PVED-CLS KWP2000 Protocol.



8 External sensors

For being able to start up the PVED-CLS in operational mode/off-road steering mode, the below mentioned sensors can be connected to the PVED-CLS before start-up and the WAS and spool dead-bands must be calibrated. If WAS and SASA sensors are absent, then the FDA can be disabled, to avoid PVED-CLS from going into safe state (refer chapter 14, for details on FDA). Furthermore, if the system is an OSPE/EHi-E or EHi-H system, the Cut-off valve must also be connected as a boot-up check is done on the Cut-off Valve presence.

Note: The system requires an MMI installed for changing programs, steering devices and steering modes etc.

For further information regarding sub-system requirements, please see the Danfoss document, PVED-CLS Safety Manual.

For further information regarding protocol requirements, please see the Danfoss document, PVED-CLS Communication protocol.

8.1 WHEEL ANGLE SENSOR

The PVED-CLS can interface with *either* single/dual channel analogue wheel angle sensor *or* dual channel CAN based wheel angle sensor, but can also be configured to no wheel angle sensor present.

Wheel angle sensor can be configured by parameters WAS interface (P3244) and Redundant WAS present (P3245).

The wheel angle sensor allows the PVED-CLS to perform closed loop position control on the steered wheels of the vehicle, auto-guidance steering, anti-drift function as well as soft end stop features.

Important

Recommended WAS specification:

WAS on CAN = 1000 counts full scale from full left to full right. Noise less than 3% full scale

WAS analogue = Minimum 3V bandwidth full left to full right. Noise less than 3% full scale.

8.1.1 No Wheel angle sensor

If no wheel angle present in the system, parameter P3244 i.e. *WAS interface* shall be set to NONE. In this case, PVED-CLS cannot perform closed loop control of the steered wheels, so auto-guidance or closed loop AUX joystick is not possible. In addition, anti-drift and soft end-stop is impossible. When wheel angle sensor is disabled, the following parameters must be set according to Table 22.

Parameter Name	Address	Description of parameter	Expected Value	Unit
When WAS interface (P3244) == NONE				
STW anti-drift - Max flow correction in percentage of full flow	P3569	Max flow correction which can be requested by the EFU algorithm	0	%
AUX anti-drift - Max flow correction in percentages of full flow	P3705	Max flow correction which can be requested by the EFU algorithm	0	%
Valve type	P3081	Valve type on which the PVED-CLS is mounted Valid Values: 0 (OSPE, EHi); 1 (EHPS)	0	-
GPS present	P3237	GPS Present/Not Present Valid Values: 0 (NOT PRESENT); 255 (PRESENT)	0	-
GPS2 present	P3238	GPS2 Present/Not Present Valid Values: 0 (NOT PRESENT); 255 (PRESENT)	0	-



If AUX present (P3239) == TRUE, then				
AUX type	P3240	Aux device is mini steering wheel or Joystick Valid Values: 0 (Open Loop Joystick); 1 (Closed Loop Joystick); 2 (mini steering wheel); 3 (Analogue Joystick);20 (Elobau joystick)	≠1	-

Table 22

If these rules are not followed, PVED-CLS will enter safe state.

8.2 SPEED SENSOR

Many of the PVED-CLS’s safety functions are relying on a safe and trustworthy vehicle speed signal. The PVED-CLS is performing crosschecks on the vehicle speed signal, therefore it is also required to send (on the CAN bus) two independent vehicle speed signals (e.g. from two sensor sub-systems).

8.3 SASAIID SENSOR

Similar to the speed sensor, the PVED-CLS’s relies on a safe steering wheel feedback from the SASAIID sensor (not used in EHi-H system, refer section 7.1.4). The SASAIID sensor is designed to send a redundant CAN-message containing both steering wheel position and steering wheel velocity. The PVED-CLS performs cross checks on both the steering wheel position and the steering wheel velocity.



9 Calibration

A PVED-CLS shall always be calibrated to the valve it is controlling (OSPE, EHPS, EHi-E or EHi-H). This allows cancellation of mechanical, electrical and environmental dependent tolerances. Spool calibration also compensates for the mechanical dead-bands designed into the EH spool. Spool calibration is only required at first installation or after PVED-CLS replacement. PVED-CLS utilizes two types of dead bands: close loop dead band used in Auto-guidance mode and open loop dead band used in EH steering features.

When using PVED-CLS for fast steering, correctly calibrated dead-bands values (P1 and P2) are important. If P1 and P2 are too-close-to-neutral (conservative values), no EH flow will be added at low steering wheel RPM, causing understeer. If P1 and P2 are further away from neutral than they should be (aggressive values), EH-flow contribution will be higher than expected at low RPM.

For AUX mini-wheel steering, having P1 and P2 too-close-to-neutral (conservative values) causes no steering at low mini-wheel steering RPM. If P1 and P2 are too far away from neutral (aggressive values) jerky mini-wheel steering, when steering motion starts.

For open loop joystick, having P1 and P2 too-close-to-neutral (conservative values) causes extra perceived dead-band in the joystick. If P1 and P2 are too far away from neutral (aggressive values) makes it impossible to steer small amounts of flow, potentially leading to jerk.

For closed loop joystick having P1 and P2 too-close-to-neutral (conservative values), will cause slight increase in possible steady state error. If P1 and P2 are too far away from neutral (aggressive values) could cause the wheels never to settle at a position (oscillation around the set-point).

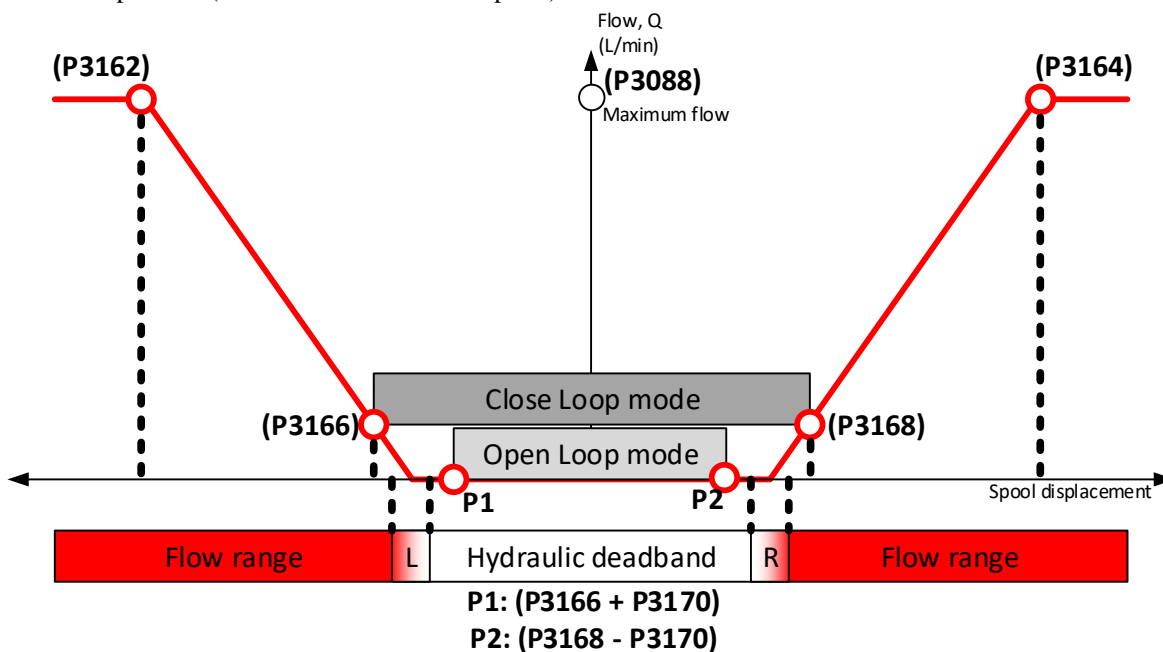

Figure 2

Close loop mode for auto-guidance are placed further away from neutral. They should be placed where definite, yet small oil output of the EH spool is achieved.

This is to eliminate steady state error between wheel angle and its set-point. The PVED-CLS will potentially oscillate a bit around steady state, but in auto-guidance there is never a steady state set-point.

If dead-bands are too far away from neutral, jerky steering at small flow can be observed, and if placed further in towards neutral it will lead to undesired periods of no EH flow output.



Important

Danfoss recommend to perform calibration under the following circumstances:

- Oil temperature during calibration routine should be at normal operating condition.
- Steered wheels characteristics (air pressure, dimension) needs to be according to the normal operation conditions.
- It needs to be ensured that the wheel angle sensors mechanical installation is fixed in such a way that there is no mechanical backlash, e.g. full fixation and alignment of WAS.
- Load on vehicle is allowed during calibration, but it needs to be assured that maximum steering pressure during calibration routine is <80% of Relief valve setting (e.g., Relief valve setting of 200bar, max steering pressure during calibration: 160bar).
- It needs to be ensured that the steering valve is supplied by sufficient oil flow during the calibration routine.
- Before any calibration routine is started, it has to be assured that all air has been bled from the steering system. This can be obtained by turning the steering wheel fully left, fully right minimum 10 times. Thereafter no abnormal noise or vibration should occur when steering.
- Any calibration should be performed on an on-road surface (i.e. unpainted concrete or asphalt). Danfoss recommends not to perform calibration on ice-surface, off-road-surface (mud, dirt etc.) or a painted, sticky surface. The vehicle should not be lifted from the ground during calibration.
- The WAS shall be calibrated prior to spool calibration

Important

Danfoss recommends to test and qualify the valve auto-calibration parameters for any vehicle series.

Attention



When performing calibration, the wheels will be moving. Make sure that there's no bystanders or that bystanders are aware of the upcoming calibration routine and the moving wheels.

9.1 WHEEL ANGLE SENSOR CALIBRATION

As per default, a PVED-CLS will boot-up in WAS calibration service mode if P3244 i.e. WAS interface is set to either analogue or CAN. From here either WAS auto-calibration routine from the Danfoss PLUS+1 SERVICE TOOL can be used or a manual WAS calibration can be performed (see 17.6).

General guidelines:

- WAS on CAN = minimum 1000 counts full scale from full left to full right. Noise less than 3% full scale
- WAS analogue = minimum 3V bandwidth full left to full right. Noise less than 3% full scale.
- The wheel angle sensor output must remain inside the range from 0.5VDC to 4.5VDC to keep clear of short circuit detection thresholds.
- Danfoss recommends that the manual calibration of any wheel angle sensors is done with the PVED-CLS in "WAS calibration service mode"
- For applications other than auto guidance, WAS resolution from 20 to 45 deg/volt will provide adequate results

Furthermore; at every startup, the PVED-CLS validates the CAN wheel angle calibration data (for CAN WAS) and Analogue Sensor calibration data (for analogue WAS) sectors;

For the "CAN Wheel Angle Sensor sector" (see 17.4.4) this means that:

P3185 < P3189 < P3187 or P3185 > P3189 > P3187; if this validation fails, PVED-CLS will enter "Wheel Angle Sensor calibration", but only if WAS type is set to CAN (i.e. P3244 set to 1).

For the "Analogue Wheel Angle Sensor" (see 17.4.5) this means that:

P3205 < P3209 < P3207 or P3205 > P3209 > P3207 and P3211 < P3215 < P3213 or P3211 > P3215 > P3213; if this validation fails, PVED-CLS will enter "Wheel Angle Sensor calibration", but only if WAS type is set to Analogue (i.e. P3244 set to 0).



Important

If WAS is not configured, i.e. parameter P3244, is set to NONE, the calibration cannot be performed and PVED-CLS will signal this in the operation status message. For more details on operational status message, please see the Danfoss document- PVED-CLS communication Protocol.

9.1.1 Automatic adjustment of maximum steer angles and cylinder stroke volume

At wheel angle sensor calibration scenarios, automatic re-calculation of the maximum wheel angle as well as cylinder stroke can be enabled. This may be useful if the wheel angle range is restricted e.g. by changing from single to twin tires or vice versa. The PVED-CLS will estimate new values for the maximum steer angle parameters as well as left and right cylinder stroke volume.

To use the automatic adjustment calculation, the wheel angle sensor characteristics must be mapped into the following 4 lookup tables (Table 24 to Table 27). The PVED-CLS will then calculate new values for the Maximum steer angle, Left and Right and Cylinder stroke volume, based on the input from the lookup tables.

PVED-CLS supports both to calculate the maximum steer angles and the cylinder stroke volume, but it is also possible only to calculate the maximum steer angles or the cylinder stroke volume.

The automatic adjusted function will be applied during WAS calibration if minimum one of the following conditions are met:

- If P3086 is set to a value > 10000 , that forces the PVED-CLS to calculate and use automatic adjusted values for cylinder stroke volume (i.e. P3191 or P3221 will be updated after WAS calibration, depending on WAS-type, using linear interpolation in Table 24 and Table 25)
- If P3426 is set to a value > 89 and if P3428 is set to a value > 89 , that forces the PVED-CLS to calculate and use automatic adjusted values for Maximum steer angle, Left (i.e. P3193 or P3223 will be updated after WAS calibration, depending on WAS-type, by lookup in Table 26), and forces the PVED-CLS to calculate and use automatic adjusted values for Maximum steer angle, Right (i.e. P3195 or P3225 will be updated after WAS calibration, depending on WAS-type, by lookup in Table 27)

Important

PVED-CLS executes EEPROM parameter crosschecks related to automatic calculation of maximum steer angles and the cylinder stroke volume.

If the automatic adjustment of maximum steer angles and cylinder stroke volume is activated (P3426 & P3428 > 89 deg and P3086 > 10000 ccm) and:

- *Analogue wheel angle sensors are in use, it is required that P3223 & P3225 ≤ 89 deg and P3221 ≤ 10000 ccm.*
- *CAN based wheel angle sensors are in use, it is required that P3193 & P3195 ≤ 89 deg and P3191 ≤ 10000 ccm.*

If these rules are not followed, PVED-CLS will enter safe state.



Name	Address	Data type	Unit	Description of parameter	User	Range		Danfoss default value	Safety critical parameters 'S'
						Min.	Max.		
Automatically adjusted cylinder stroke volume (CAN WAS)	P3191	U16	ccm	Automatically adjusted cylinder stroke volume, for using CAN WAS, found during WAS auto-calibration	OEM, Dealer	100	65535	65535	
Automatically adjusted maximum steer angle to left side (CAN WAS)	P3193	U16	Deg	Automatically adjusted maximum steer angle to left side, for using CAN WAS, found during WAS auto-calibration	OEM, Dealer	0	65535	65535	
Automatically adjusted maximum steer angle to right side (CAN WAS)	P3195	U16	Deg	Automatically adjusted maximum steer angle to right side, for using CAN WAS, found during WAS auto-calibration	OEM, Dealer	0	65535	65535	
Automatically adjusted cylinder stroke volume (analogue WAS)	P3221	U16	ccm	Automatically adjusted cylinder stroke volume, for using analogue WAS, found during WAS auto-calibration	OEM, Dealer	100	65535	65535	
Automatically adjusted maximum steer angle to left side (analogue WAS)	P3223	U16	Deg	Automatically adjusted maximum steer angle to left side, for using analogue WAS, found during WAS auto-calibration	OEM, Dealer	0	65535	65535	
Automatically adjusted maximum steer angle to right side (analogue WAS)	P3225	U16	Deg	Automatically adjusted maximum steer angle to right side, for using analogue WAS, found during WAS auto-calibration	OEM, Dealer	0	65535	65535	

Table 23

Important

If P3086 is set to a value > 10000, the following consistency check is done: If the voltage base parameter, P3821, is found to be < |Captured left most position – Captured neutral position|, the consistency check will fail and the WAS calibration will be aborted

Important

If P3086 is set to a value > 10000, the following consistency check is done: If the voltage base parameter, P3829, is found to be < |Captured right most position – Captured neutral position|, the consistency check will fail and the WAS calibration will be aborted

Important

If P3426 is set to a value > 89, the following consistency check is done: If the voltage base parameter, P3834, is found to be < |Captured left most position – Captured neutral position|, the consistency check will fail and the WAS calibration will be aborted

Important

If P3428 is set to a value > 89, the following consistency check is done: If the voltage base parameter, P3839, is found to be < |Captured right most position – Captured neutral position|, the consistency check will fail and the WAS calibration will be aborted

where; “captured right/left most position” and “captured neutral position” is the values in mVolts captured during WAS calibration, regardless if analogue or CAN based WAS is used.



Important

Mapping of the look-up tables has to be done, when maximum possible steer angles can be achieved. Has to support maximum achievable voltages between neutral and right most as well as between neutral and left most. Add some tolerance. In most cases this voltage will be asymmetrical, and base voltages should be so as well, for maximum precision. If sensor gain is changed lookup tables are invalidated

Name	Address	Data type	Unit	Description of parameter	User	Range		Danfoss default value	Safety critical parameters 'S'
						Min.	Max.		
WAS calibration - Mapped cyl. str. vol. (steering left) at 33% VB	P3815	U16	ccm	Mapped cylinder stroke volume (steering left) at 33% voltage base	OEM, Dealer	100	10000	333	
WAS calibration - Mapped cyl. str. vol. (steering left) at 67% VB	P3817	U16	ccm	Mapped cylinder stroke volume (steering left) at 67% voltage base	OEM, Dealer	100	10000	667	
WAS calibration - Mapped cyl. str. vol. (steering left) at 100% VB	P3819	U16	ccm	Mapped cylinder stroke volume (steering left) at 100% voltage base	OEM, Dealer	100	10000	1000	
WAS calibration - Mapped VB for cyl. str. vol. (steering left)	P3821	U16	mVolts	Mapped voltage base for cylinder stroke volume (steering left)	OEM, Dealer	0	6000	2000	

Table 24

The sensor characteristics needs to be mapped, according to Figure . The cylinder stroke volume @ 33% (P3815), 67% (P3817) and 100% (P3819) of the voltage base (P3821) should be mapped, where voltage base is:
 The absolute voltage [mVolts] from the WAS, going from neutral to left most position, when maximum possible steer angles can be achieved on the vehicle + some tolerance.

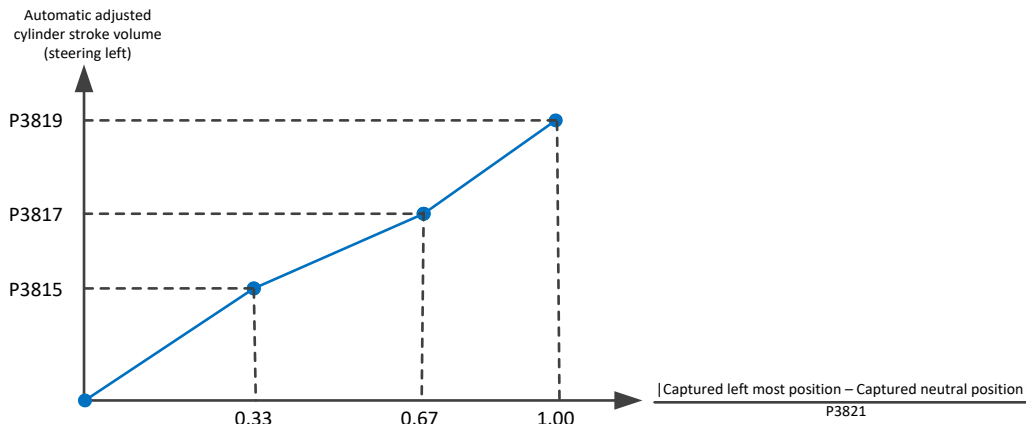

Figure 19



Name	Address	Data type	Unit	Description of parameter	User	Range		Danfoss default value	Safety critical parameters 'S'
						Min.	Max.		
WAS calibration - Mapped cyl. str. vol. (steering right) at 33% VB	P3823	U16	ccm	Mapped cylinder stroke volume (steering right) at 33% voltage base	OEM, Dealer	100	10000	333	
WAS calibration - Mapped cyl. str. vol. (steering right) at 67% VB	P3825	U16	ccm	Mapped cylinder stroke volume (steering right) at 67% voltage base	OEM, Dealer	100	10000	667	
WAS calibration - Mapped cyl. str. vol. (steering right) at 100% VB	P3827	U16	ccm	Mapped cylinder stroke volume (steering right) at 100% voltage base	OEM, Dealer	100	10000	1000	
WAS calibration - Mapped VB for cyl. str. vol. (steering right)	P3829	U16	mVolts	Mapped voltage base for cylinder stroke volume (steering right)	OEM, Dealer	0	6000	2000	

Table 25

The sensor characteristics needs to be mapped, according to Figure 1. The cylinder stroke volume @ 33% (P3823), 67% (P3825) and 100% (P3827) of the voltage base (P3829) should be mapped, where voltage base is:

The absolute voltage [mVolts] from the WAS, going from neutral to right most position, when maximum possible steer angles can be achieved on the vehicle + some tolerance.

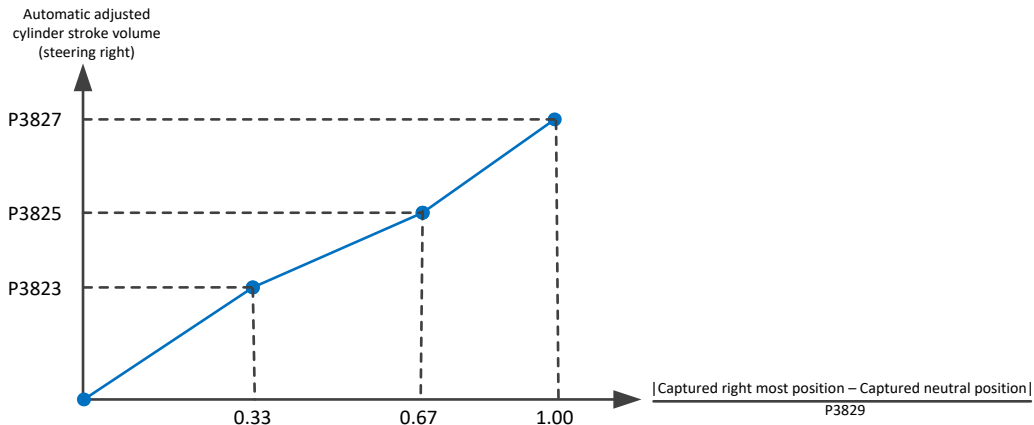

Figure 20



Name	Address	Data type	Unit	Description of parameter	User	Range		Danfoss default value	Safety critical parameters 'S'
						Min.	Max.		
WAS calibration - Mapped max WA (steering left) at 33% VB	P3831	U8	deg	Mapped maximum wheel angle (steering left) at 33% voltage base	OEM, Dealer	0	89	30	
WAS calibration - Mapped max WA (steering left) at 67% VB	P3832	U8	deg	Mapped maximum wheel angle (steering left) at 67% voltage base	OEM, Dealer	0	89	60	
WAS calibration - Mapped max WA (steering left) at 100% VB	P3833	U8	deg	Mapped maximum wheel angle (steering left) at 100% voltage base	OEM, Dealer	0	89	89	
WAS calibration - Mapped VB for max WA (steering left)	P3834	U16	mVolts	Mapped voltage base for maximum wheel angle (steering left)	OEM, Dealer	0	6000	2000	

Table 26

The sensor characteristics needs to be mapped, according to Figure 21. The steer angles @ 33% (P3831), 67% (P3832) and 100% (P3833) of the voltage base (P3834) should be mapped, where voltage base is:

The absolute voltage [mVolts] from the WAS, going from neutral to left most position, when maximum possible steer angles can be achieved on the vehicle + some tolerance.

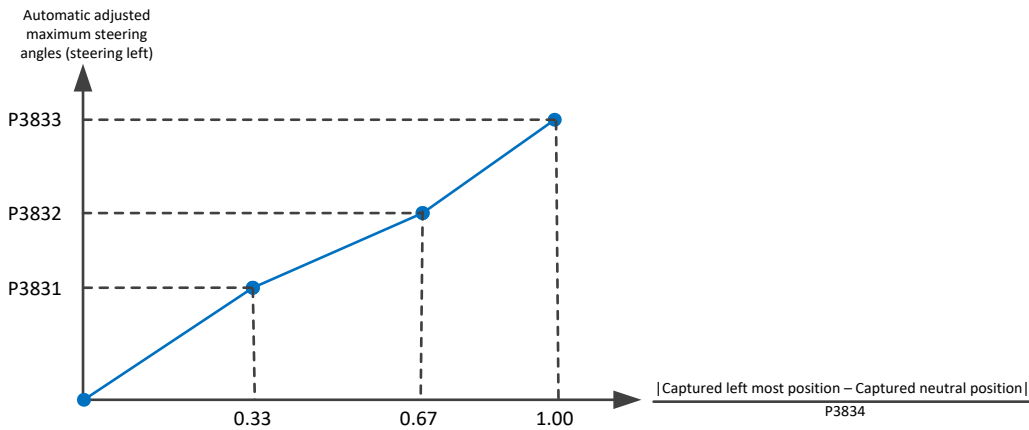

Figure 21



Name	Address	Data type	Unit	Description of parameter	User	Range		Danfoss default value	Safety critical parameters 'S'
						Min.	Max.		
WAS calibration - Mapped max WA (steering right) at 33% VB	P3836	U8	deg	Mapped maximum wheel angle (steering right) at 33% voltage base	OEM, Dealer	0	89	30	
WAS calibration - Mapped max WA (steering right) at 67% VB	P3837	U8	deg	Mapped maximum wheel angle (steering right) at 67% voltage base	OEM, Dealer	0	89	60	
WAS calibration - Mapped max WA (steering right) at 100% VB	P3838	U8	deg	Mapped maximum wheel angle (steering right) at 100% voltage base	OEM, Dealer	0	89	89	
WAS calibration - Mapped VB for max WA (steering right)	P3839	U16	mVolts	Mapped voltage base for maximum wheel angle (steering right)	OEM, Dealer	0	6000	2000	

Table 27

The sensor characteristics needs to be mapped, according to Figure 22. The steer angles @ 33% (P3836), 67% (P3837) and 100% (P3838) of the voltage base (P3839) should be mapped, where voltage base is:
The absolute voltage [mVolts] from the WAS, going from neutral to right most position, when maximum possible steer angles can be achieved on the vehicle + some tolerance.

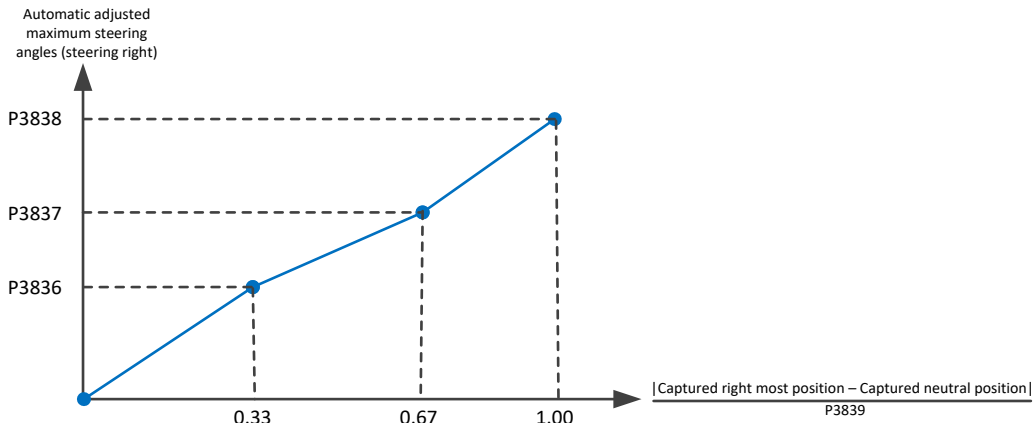

Figure 22



9.2 ANALOGUE JOYSTICK CALIBRATION

As per default, PVED-CLS will boot-up in Analogue joystick calibration service mode after one of the below conditions is reached

- If WAS interface i.e.P3244 is set to CAN AND AUX Present i.e. P3239 is set to TRUE and AUX Type i.e. P3240 is set to analogue joystick, and a successful WAS calibration has been completed.
- If WAS interface i.e.P3244 is set to NONE AND AUX Present i.e. P3239 is set to TRUE and AUX Type i.e. P3240 is set to analogue joystick.

From here, the analogue joystick auto-calibration routine from the Danfoss PLUS+1 SERVICE TOOL can be used. Additionally, at every boot-up, the PVED-CLS validates the Analogue Sensor calibration data sectors (for analogue Joystick), so for the “Analogue joystick” (see 17.4.5)

PVED-CLS will enter “Analogue joystick calibration”, If either of the below condition fails

- $P3205 < P3209 < P3207$ or $P3205 > P3209 > P3207$
- $P3211 < P3215 < P3213$ or $P3211 > P3215 > P3213$

9.3 SPOOL CALIBRATION

As per default, a PVED-CLS will boot-up in spool calibration service mode after a successful WAS calibration, if WAS interface (i.e. P3244) is set to either analogue or CAN, has been completed. From here either the spool auto-calibration routine from the Danfoss PLUS+1 SERVICE TOOL can be used or a manual spool calibration can be performed, using the direct output control function.

The PVED-CLS shall be calibrated to the OSPE, EHi or EHPS valve in order to achieve optimum and consistent steering performance in terms of auto-guidance precision and fast-steering performance.

A valve can be calibrated in more ways. Common for all the procedure is that the goal is to:

- Find the optimum minimum spool position set-points for closed-loop wheel position control
- Find the optimum minimum spool position set-points for open-loop flow control

Danfoss recommends using the direct spool control to find the optimal closed-loop dead-bands. When these have been determined, a constant steady movement of the wheels relationship can be found, hence how many degrees the wheels turn per second. This relationship is to be used as acceptance criteria, when designing the Auto-calibration parameter-set.

Example:

Using direct output control, two closed loop dead-band values have been found ($P3166 = -90$; $P3168 = 100$), and a constant steady movement of the wheels relationship has been measured (2° per second).

When designing the Auto-calibration parameter set, use the maximum closed loop dead-band value as your *Spool calibration - Initial spool position* ($P3802 = 100$) and use the constant steady movement of the wheels relationship (2° per second) for setting the following 3 parameters:

- Spool calibration - +/- turn range sweep (e.g. $P3804 = +/- 2,5^\circ$, hence P3804 set to 25)
- Spool calibration - Max time for acceptable CL dead-band edge (e.g. $P3806 = 3$ seconds, hence P3806 set to 30)
- Spool calibration - Min time for acceptable CL dead-band edge (e.g. $P3808 = 2$ seconds, hence P3808 set to 20)

The acceptance criteria (P3806 and P3808) with a given range (P3804) can be decided. Having a narrower acceptance criteria, gives a more precise dead-band calibration, but could potentially take longer time to tune.

9.3.1 Prerequisites

Prior to spool calibration, the wheel angle sensors shall be calibrated, the calibration counters and bit inverted copy for WAS calibration should be updated and a sufficiently large signal to noise ratio shall be ensured (see chapter 9.1). Valve calibration shall be done when the PVED-CLS is in service mode, either “Spool calibration” or “Direct output control”.



9.3.2 Spool calibration overview

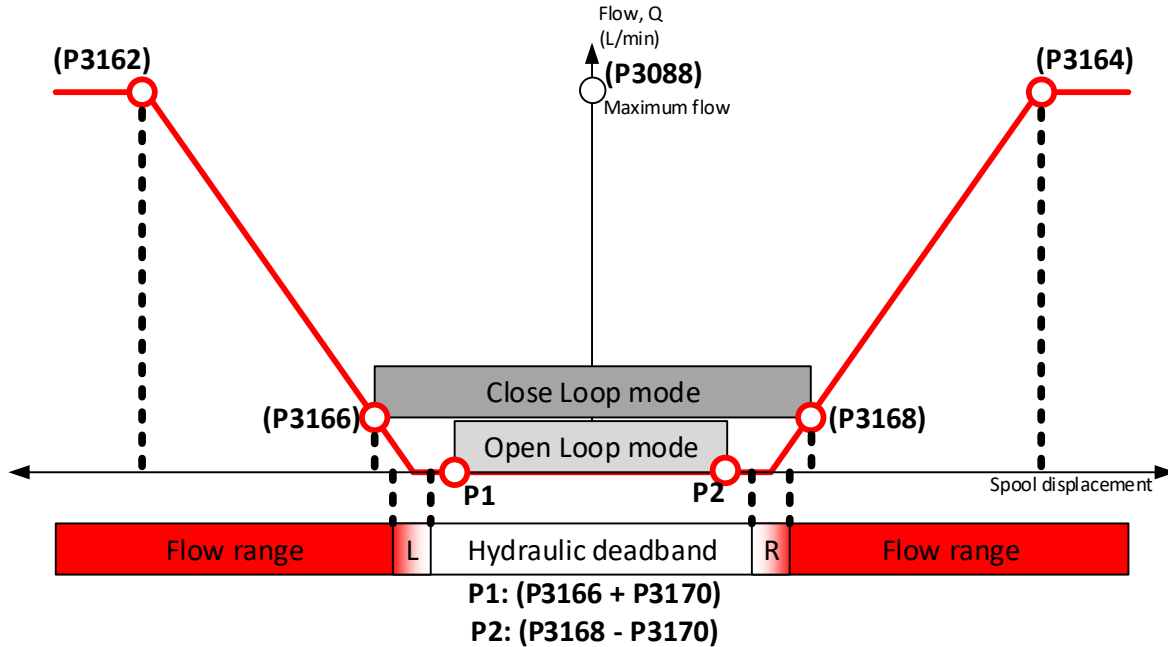

Figure 23

P3162 and P3164 define the maximum spool stroke and are set to the stroke length where the spool is mechanically stopped by the valve. P3162 and P3164 is usually not calibrated.

P3166 and P3168 define the closed-loop dead-band spool positions known to the software.

Parameter P3170 is a spool position offset which is added/subtracted (P1 and P2) to the spool position set-points in open-loop only. P3170 is usually not calibrated per machine, but designed as a fixed value, for each application or potentially for each application models.

Name	Address	Data type	Unit	Description of parameter	User	Range		Danfoss default value	Safety critical parameters 'S'
						Min.	Max.		
Max spool position, left	P3162	S16	x10u Meter	Spool left most position	OEM, Dealer	-1000	-300	-420	
Max spool position, right	P3164	S16	x10u Meter	Spool right most position	OEM, Dealer	300	1000	420	
Closed loop dead-band edge, left	P3166	S16	x10u Meter	Spool closed loop dead-band edge, Left	OEM, Dealer	-300	0	-105	
Closed loop dead-band edge, right	P3168	S16	x10u Meter	Spool closed loop dead-band edge, Right	OEM, Dealer	0	300	105	
Open loop dead-band edge offset	P3170	S16	x10u Meter	Spool open loop dead-band offset	OEM, Dealer	0	150	25	

Table 28



Important

Danfoss recommends that the manual spool calibration (Direct Output control) is used for calibrating the dead-band of a spool on a single vehicle, and the findings for a specific vehicle type should be used as input for defining an auto-calibration parameter set, to be used on a production line.

For manual spool calibration to move spool directly, go to “Direct output control” in the PLUS+1 SERVICE TOOL

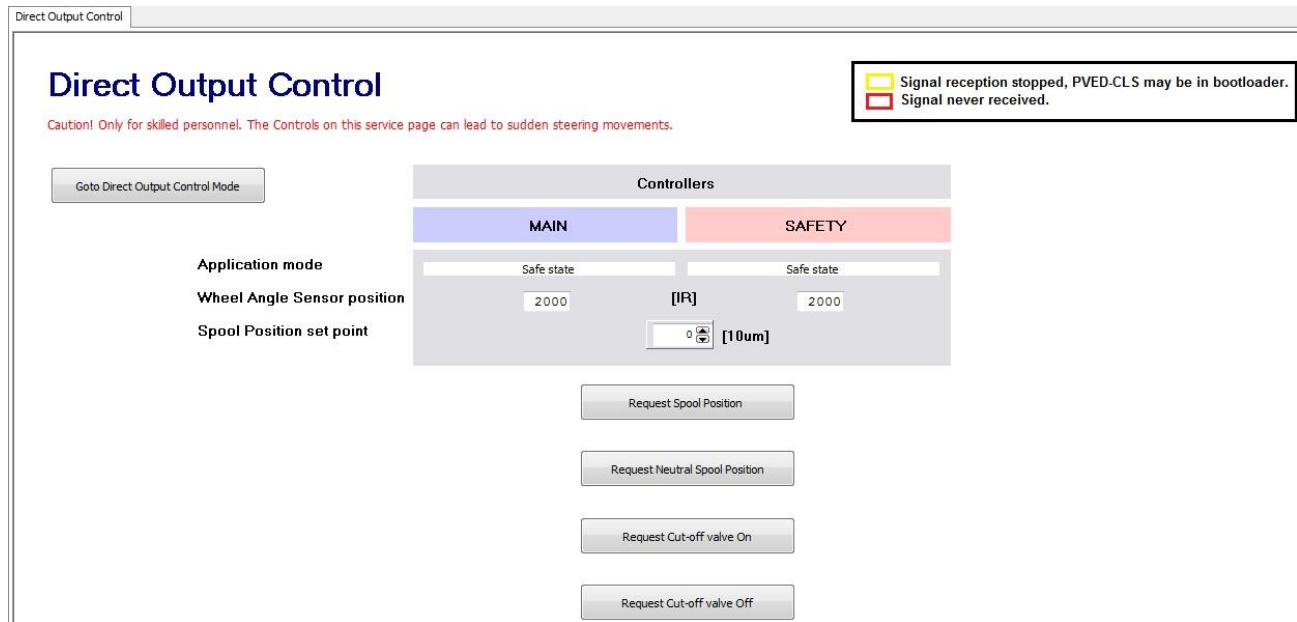

Figure 24

In the “Spool Position set-point”, the desired spool position can be entered/set, in a resolution of 10µm. By putting in a number in the “Spool Position set-point”, the spool will not move. First, it need to request the Cut-off valve to be “On” (for an OSPE/EHi-system) and then press the “Request spool position”-button.

At any point in time the spool can be forced back to neutral by pushing “Request Cut-off valve Off”-button (only for OSPE/EHi) or by pressing the “Request Neutral Spool Position”-button.

Warning



When using the Direct Output Control function in the PVED-CLS, all safety functions are disabled. The user has to be a skilled operator and must be aware that using this functionality can lead to sudden steering movements!

Important

If WAS is not configured, i.e. parameter P3244, is set to NONE, the calibration cannot be performed and PVED-CLS will signal this in the operation status message. For more details on operational status message, please see the Danfoss document- PVED-CLS communication Protocol.



9.4 AUTO-CALIBRATION

If an OEM does not want to develop their own auto-calibration routine, the PVED-CLS offers a build-in auto-calibration function, which can be invoked from the PLUS+1 SERVICE TOOL or an external tool by using the service CAN messages. The auto-calibration is divided into three separate calibration routines; one for the WAS one for the spool and one for Joystick.

As per default, the PVED-CLS will boot-up in WAS calibration service mode if, depending on the WAS interface type (P3244), the corresponding counter-parameter and bit inverted counter-parameter are set to 0 and 255, respectively.

Name	Address	Data type	Unit	Description of parameter	User	Range		Danfoss default value	Safety critical parameters 'S'
						Min.	Max.		
WAS interface	P3244	U8	-	Wheel Angle Sensor Interface Type Valid Values: 0 (ANALOGUE); 1 (CAN); 2 (NONE)	OEM	0	2	0	
Spool dead-band Calibration counter	P3771	U8	-	Spool dead-band Calibration counter	OEM	0	255	0	
Bit inverted value for Spool dead-band Calibration counter	P3772	U8	-	Bit inverted value for Spool dead-band Calibration counter	OEM	0	255	255	
Analogue WAS calibration counter	P3773	U8	-	Analogue WAS calibration counter	OEM	0	255	0	
Bit inverted value Analogue WAS calibration counter	P3774	U8	-	Bit inverted value Analogue WAS calibration counter	OEM	0	255	255	
CAN based WAS calibration counter	P3775	U8	-	CAN based WAS calibration counter	OEM	0	255	0	
Bit inverted value for CAN based WAS calibration counter	P3776	U8	-	Bit inverted value for CAN based WAS calibration counter	OEM	0	255	255	
Calibration counter - Analogue joystick	P3777	U8	-	Analogue sensor based Joystick calibration counter	OEM	0	255	0	
Bit inverted value for "Calibration counter - Analogue joystick"	P3778	U8	-	Bit inverted value for Analogue sensor based Joystick calibration counter	OEM	0	255	255	

Table 29

Prioritization is as follows:

1. The PVED-CLS will boot into *WAS calibration service mode* if one of the below condition is true.
 - A. If P3244 (WAS interface) is set to 0, P3773 is set to 0 and P3774 is set to 255.
OR
 - B. If P3244 (WAS interface) is set to 1, P3775 is set to 0 and P3776 is set to 255.
2. PVED-CLS will boot into *Joystick calibration service mode* if one of the below condition is true
 - A. If P3244 (WAS interface) is set to 1, condition 1B is not fulfilled, P3777 set to 0 and P3778 set to 255.
OR
 - B. If P3244 is set to 2, P3777 is set to 0 and P3778 set to 255.
3. PVED-CLS will go into *Spool calibration service mode* if P3244 (WAS interface) is set to 1 or 0, the conditions 1A, 1B and 2A are not fulfilled, P3771 is set to 0 and P3772 is set to 255.
4. If the all the above conditions, 1 to 3, are not fulfilled then the PVED-CLS will boot in "operation mode".



9.4.1 Initial setup

WAS:

The function works by capturing the leftmost, rightmost and straight ahead position of the wheels. The function will learn the relationship between the AD/CAN values of the WAS for the whole steering band (from leftmost position to rightmost position) and scale this into an internal resolution in steps of 0.1% for the steering (leftmost to straight ahead and straight ahead to rightmost).

Joystick:

The function works by capturing the leftmost, rightmost and neutral position of the Analogue Joystick. The function will learn the relationship between the analogue sensor values of the joystick for the whole joystick position range (from leftmost position to rightmost position) and scale this into an internal resolution in steps of 0.1% for the joystick position (leftmost to straight ahead and straight ahead to rightmost).

Spool:

This function allows the determination of the spool dead-band based on inputs and demands from the operator. The spool dead-band is determined (within given inputs) by measuring the duration of moving the spool continuously from left to right.

The function is intended to be an alternative solution for spool calibration for mass production environments where a large number of vehicles is produced and a quick automated spool calibration is needed. The function can provide a precise dead-band calibration of the spool in a relatively short time (depending on the parameter setup) without having an operator directly involved.

Before starting any auto-calibration, the parameters in the sector “Auto-calibration Config” shall be studied, as these are important to get the desired setup on the vehicle.

Auto-calibration Config

Name	Address	Data type	Unit	Description of parameter	User	Range		Danfoss default value	Safety critical parameters ‘S’
						Min.	Max.		
Analogue sensor calibration - Max allowable analogue sensor signal to be captured in neutral	P3791	U16	mVolts	Maximum allowed signal to be captured for neutral position during Analogue sensor auto-calibration	OEM, Dealer	0	5000	4500	
Analogue sensor calibration - Min voltage needed in between the captured analogue sensor values	P3793	U16	mVolts	Determines the minimum voltage needed in between the captured Analogue sensor voltage (minimum, neutral and maximum), to ensure a sufficient high analogue signal resolution during Analogue sensor auto-calibration.	OEM, Dealer	0	2500	0	
Analogue sensor calibration - Min allowable analogue sensor signal to be captured in neutral	P3795	U16	mVolts	Minimum allowed signal to be captured for neutral position during analogue sensor auto-calibration.	OEM, Dealer	0	5000	500	
Spool calibration - Max closed loop dead-band edge	P3797	U16	x10u Meter	Maximum closed loop dead-band value (for both left- and right-side), hence the found dead-band values needs to be in between P3799 and P3797.	OEM, Dealer	0	300	300	
Spool calibration - Min closed loop dead-band edge	P3799	U16	x10u Meter	Minimum closed loop dead-band value (for both left- and right-side), hence the found dead-band values needs to be in between P3799 and P3797.	OEM, Dealer	0	300	0	
Spool calibration - Activation timeout	P3801	U8	-	The time window the user has to start the spool auto-calibration (i.e. to press the “Start Calibration” button) after the steering wheel has been activated and the motion has stopped again	OEM, Dealer	1	60	20	
Spool calibration - Initial spool position	P3802	U16	x10u Meter	The initial spool position value, the spool auto-calibration function will start at. The higher set-point, the faster the wheels movement will be. Recommend: 115 for OSPE/EHi; 200 for EHPS	OEM, Dealer	50	300	125	



Spool calibration - +/- turn range sweep	P3804	U16	dDeg	This is the +/- turn range sweep where the auto-calibration function will measure the time for when moving the spool from left to right and right to left. Resolution: 1 dDeg 1 = 0,1°.	OEM, Dealer	5	400	25	
Spool calibration - Max time for acceptable CL dead-band edge	P3806	U16	x100msec	P3806 and P3808 indicate the target sweep time for the spool calibration function, to find an acceptable closed loop dead-band edge. That maximum given time is defined by P3806	OEM, Dealer	10	600	110	
Spool calibration - Min time for acceptable CL dead-band edge	P3808	U16	x100msec	P3806 and P3808 indicate the target sweep time for the spool calibration function, to find an acceptable closed loop dead-band edge. The minimum given time is defined by P3808	OEM, Dealer	10	600	60	
Spool calibration - Vector sample size	P3810	U8	-	In most cases, to find an acceptable closed loop dead-band edge within a given time frame requires more attempts (to ensure consistency in the captured/found values). P3810 defines the vector size for how many attempts (for left- and right-side dead-band edge, respectively) should be considered	OEM, Dealer	1	10	7	
Spool calibration - Min valid samples	P3811	U8	-	P3811 defines how many of the attempts (defined by P3810) that need to be equal to get a successful spool calibration.	OEM, Dealer	1	10	5	
Spool calibration - +/- turn range sweep add-on	P3812	U16	dDeg	This indicates the additional +/- turn range, which will be added to the value in P3804. The additional turn range movement is required to obtain a stable spool position and stable wheel movement of the vehicle. The wheels will move in between this +/- turn range, but time will only be measured in between the +/- turn range specified by P3804. Resolution: 1 dDeg 1 = 0,1°.	OEM, Dealer	5	400	25	
Spool calibration - Spool set-point increase/decrease step	P3814	U8	%	When the auto-calibration function has determined that the last attempt was too slow or too fast (hence, within the time frame specified by P3806 and P3808), it will: • Too slow: add the value specified by P3814 to last set-point value. • Too fast: subtract the value specified by P3814 to last set-point value	OEM, Dealer	1	25	10	
Max allowable CAN WAS signal to be captured in Neutral	P3881	U16	mVolts	Maximum allowed signal to be captured for neutral position during CAN WAS auto-calibration	OEM, Dealer	0	5000	4500	
Min voltage needed in between the captured CAN WAS values	P3883	U16	mVolts	Determines the minimum voltage needed in between the captured CAN WAS voltage (minimum, neutral and maximum), to ensure a sufficient high wheel angle resolution during CAN WAS auto-calibration.	OEM, Dealer	0	2500	0	
Min allowable CAN WAS signal to be captured in Neutral	P3885	U16	mVolts	Minimum allowed signal to be captured for neutral position during CAN WAS auto-calibration	OEM, Dealer	0	5000	500	

Table 30

9.4.1.1 Auto-calibration parameter plausibility check

P3791, P3795:

Maximum and minimum allowed analogue sensor signal to be captured for analogue sensor (WAS or Joystick) neutral position. This is applicable for primary and redundant analogue sensor.

- P3795 < “captured neutral analogue sensor signal value” < P3791.

Important

The analogue sensor auto-calibration routine will return an error message if the straight heading falls outside the range. Use these parameters to control the straight heading range.

P3793:

Determines the minimum voltage needed in between the captured analogue sensor values (minimum, neutral and maximum), to ensure a sufficiently high analogue sensor resolution. The algorithm will determine if left or right has the highest value. This is applicable for primary and redundant analogue sensor.

- “Captured rightmost analogue sensor values” - “Captured neutral analogue sensor values” ≥ P3793 and “Captured neutral analogue sensor values” - “Captured leftmost analogue sensor values” ≥ P3793.

or

- “Captured leftmost analogue sensor values” - “Captured neutral analogue sensor values” ≥ P3793 and “Captured neutral analogue sensor values” - “Captured rightmost analogue sensor values” ≥ P3793

Important

The WAS or Joystick auto-calibration routine will return an error message if detected analogue sensor calibration values result in a too small working range.

P3797, P3799:

Maximum and minimum closed loop dead-band value (for both left and right-side), hence the found dead-band values needs to be in between P3799 and P3797.

- Right: $P3799 \leq \text{“test_db_R”} \leq P3797$; knowing that “test_db_R” will be found during the spool calibration and be equal to P3168.
- Left: $-P3797 \leq \text{“test_db_L”} \leq -P3799$; knowing that “test_db_L” will be found during the spool calibration and be equal to P3166.

Important

These parameters control the risk of effectuating non plausible large closed-loop dead-band values.

P3801:

Before automatic spool calibration can be started, the steering wheel has to be armed first. This is to tell the PVED-CLS, that grabbing the steering wheel can be detected, and thus can be used to disengage ongoing spool calibration.

In the operation status message, byte 4 (see PVED-CLS communication protocol, chapter 7.10), the Spool calibration status can be observed.

- 0x21: Spool calibration inactive – Steering wheel has not been armed yet.
- 0x22: Spool calibration getting armed – the steering is being operated to “STW_ON” (see 3.6)
- 0x23: Spool calibration armed – steering wheel is not being operated or steering wheel operation is stopped and a counter has started. Now the “Start calibration”-button has to be pushed in the PLUS+1 Service Tool or send the message “Spool Calibration Start request” (see PVED-CLS communication protocol, chapter 5.1.1) within the counter has reached the threshold limit given by P3801 (in seconds)

P3802:

The initial spool position value, at which the spool auto-calibration function will start from. The higher the set-point, the faster the wheels movement will be.

Danfoss recommends setting P3802 set to 115 for OSPE/EHi valve and 200 for EHPS.

Important

It needs to be assured that this value is in the flow range (see Figure)

P3804:

This is the +/- turn range sweep where the auto-calibration function will measure the time for when moving the spool from left to right and right to left. P3804 is given in [dDeg], hence $1 = 0,1^\circ$. E.g. if P3804 is set to 1° , time will be measured across $\pm 1^\circ = 2^\circ$ in total.

P3806, P3808:

P3806 and P3808 indicate the target sweep time for the spool calibration function, to find an acceptable closed loop dead-band edge. That maximum given time is defined by P3806. The minimum given time is defined by P3808.

P3810, P3811:

In most cases, it requires several attempts to find an acceptable closed loop dead-band edge within a given time frame (to ensure consistency in the captured/found values).

P3810 defines the vector size for how many attempts (for left- and right-side dead-band edge, respectively) should be considered, and P3811 defines how many of these attempts needs to be equal to get a successful spool calibration.

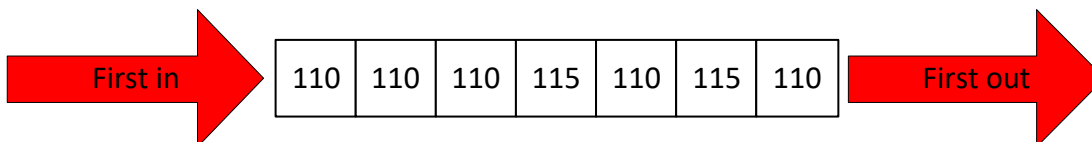

Figure 25

The above figure shows an example how an acceptable dead-band value of 110 could be achieved using default values for P3810 = 7, P3811 = 5.

The vector will keep the last seven acceptable attempts, using FIFO-principle. With default values for P3810 and P3811, 5 out of the last 7 attempts need to contain the same value. When this is true, the dead-band calibration of the spool, to the given side, has been completed.

P3812:

This indicates the additional +/- turn range, which will be added to the value in P3804. The additional turn range movement is required to obtain a stable spool position and also stable wheel movement of the vehicle. The wheels will move in between this +/- turn range, but time will only be measured in between the +/- turn range specified by P3804, as illustrated below (P3812 is given in [dDeg], hence $1 = 0,1^\circ$).

To speed up the calibration, wheel angle speed will be increased in the green zones, after red zone has ended. The speed will also be increased after the calibration in one direction has been successfully completed:

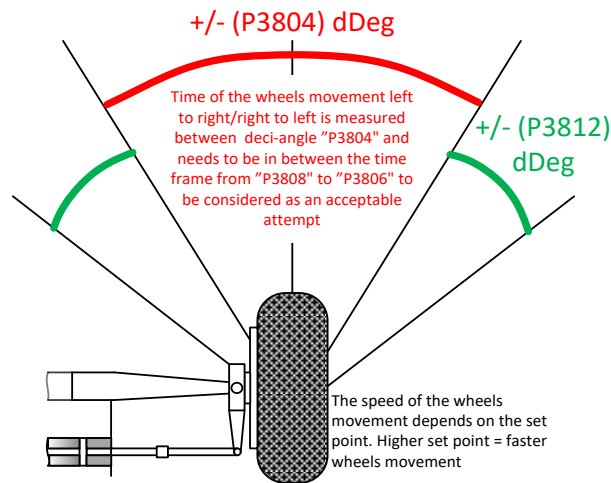

Figure 26

P3814:

To determine the spool dead-band as precise as possible, the auto-calibration function is split into 3 stages. Stage 1 is the initial turning, stage 2 is a coarse-tuning and stage 3 is fine-tuning.

During the initial turning, *stage 1*, the spool set-point is either set to the value specified by P3802 [10um] or the value specified by the 'Initial spool set point' in the CAN message 'Spool calibration start request'.

Stage 2 is entered if two attempts has been completed in stage 1, without being inside the time frame specified by parameters P3808 and P3806. During *stage 2*, the spool set-point will be reduced by the value specified by parameter P3814 [%] if the two last attempts were faster than specified by P3808. If the two last attempts were slower than specified by P3806, the spool set-point will increased by the value of P3814 [%]. In case that one of the last two attempts was faster than specified by P3808 and the other slower than specified by P3806, the new spool set-point will be the average spool set-points used during the last two attempts.

Stage 3 is entered once at least one attempt has been found inside the time frame specified by P3808 and P3806, no matter if the attempt was made in *stage 1* or *2*. During *stage 3*, the spool set-point will be reduced by 1 [10um], if the last attempt was faster than specified by P3808 and the spool set-point will be increased by 1 [10um], if the last attempt was slower than specified by P3806. This is repeated until a successful spool dead-band calibration has been achieved.



9.5 EXECUTE AUTO-CALIBRATION FROM PLUS+1 SERVICE TOOL

PVED-CLS offers WAS auto-calibration (Analogue and CAN), Joystick auto-calibration (Analogue Joystick) and Spool auto-calibration from plus+1 service tool.

In the navigation pane, find “Parameter Pages” → “Auto-Calibration” and click on appropriate function to perform auto-calibration.

Auto - Calibration

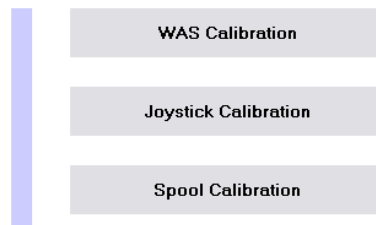

Figure 27

9.5.1 Pre-requisite

To perform auto-calibration Open the PLUS+1 service tool and execute the matching .PID-file (Software version in PVED-CLS needs to match the pages in the .PID-file).

9.5.2 Execute WAS auto-calibration from the PLUS+1 SERVICE TOOL

In the navigation pane, find “Parameter Pages” → “Auto-Calibration” → “WAS Calibration”

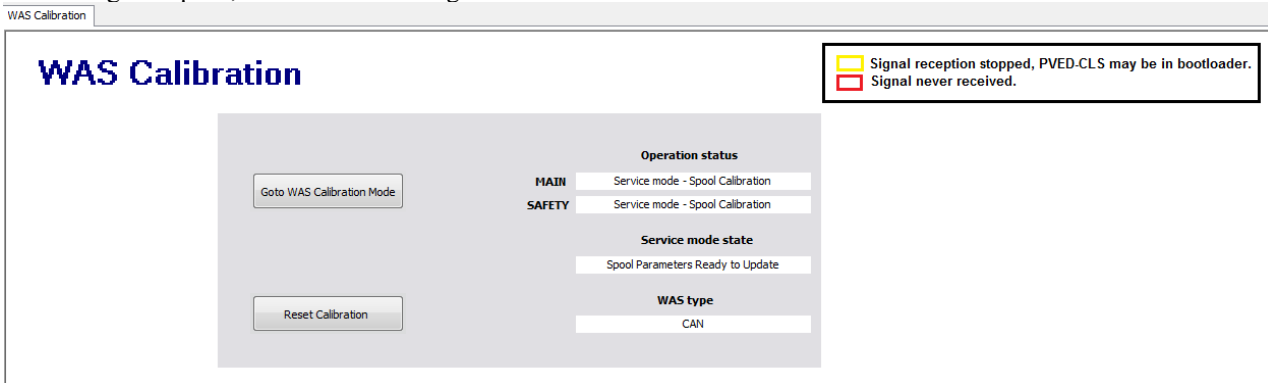

Figure 28

Press “Goto WAS Calibration Mode”. Now the leftmost, rightmost and neutral position can be captured, simply by steer the steering wheel fully left, fully right and back to neutral and press the capture buttons (Capture L, Capture N and Capture R) respectively. It doesn’t matter in which sequence this is done. Danfoss recommends to capture straight position while driving the vehicle slowly, aiming at a spot far away.

Note: Captured voltage values must be in the range of 200 mv. to 4800 mv.

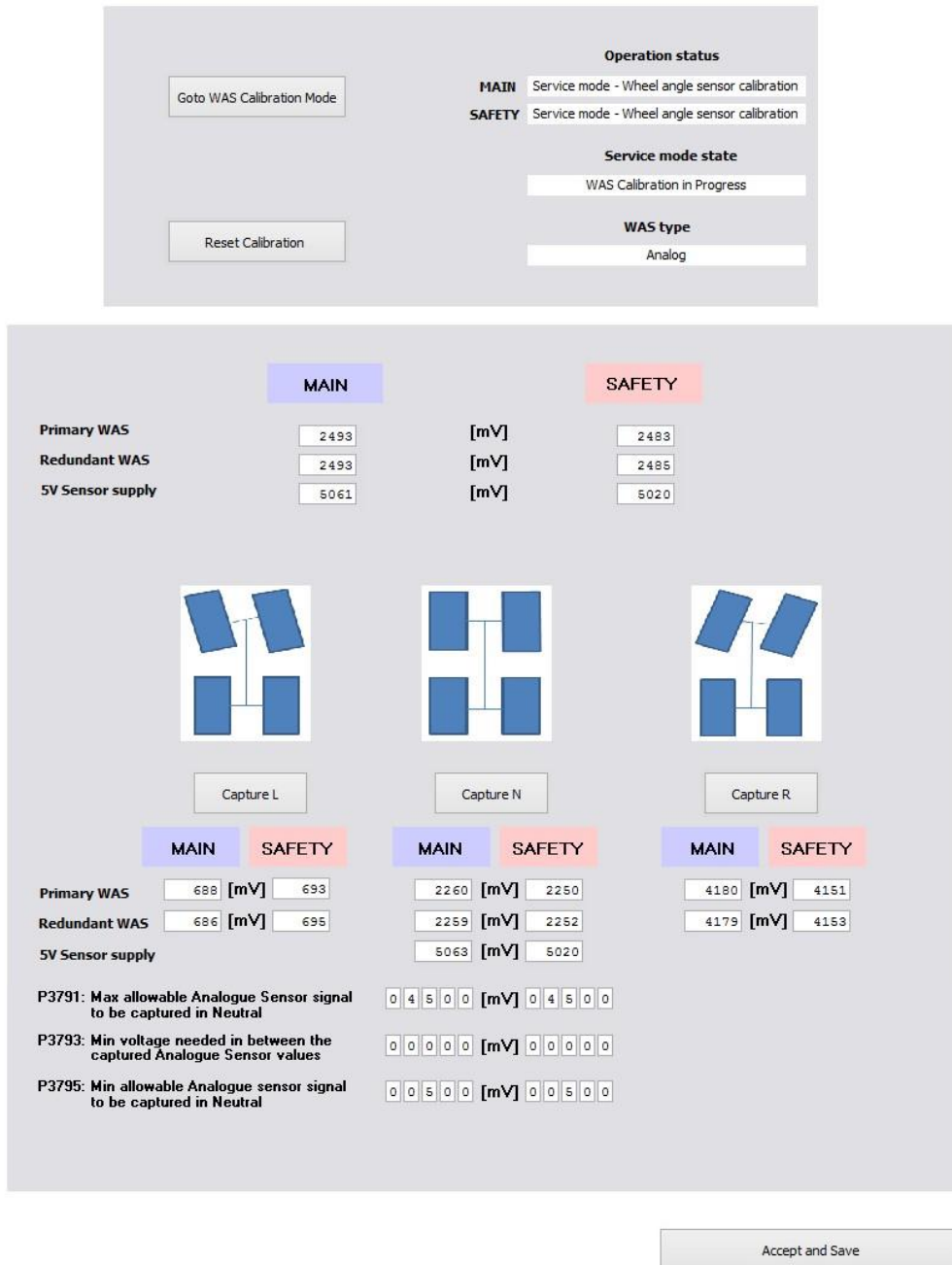

Figure 29



Whenever one of the capture-buttons has been pushed, a green bar will light up beneath it.

The screenshot displays the PVED-CLS calibration interface. At the top, the 'Operation status' shows 'MAIN' and 'SAFETY' modes, both set to 'Service mode - Wheel angle sensor calibration'. The 'Service mode state' is 'WAS Calibration Complete' and the 'WAS type' is 'Analog'. Below this, there are three 'Capture' buttons (L, N, R) with green bars indicating they have been pushed. The interface also shows 'New parameter values in the EEPROM' with a 'Read Data' button. The parameters are organized into three sections: 'Analog Wheel angle sensor', 'Redundant WAS', and 'Auto Calibration'. Each section has a table of parameters with values for MAIN and SAFETY modes.

Parameter	MAIN	SAFETY
Primary WAS	623 [mV]	636
Redundant WAS	627 [mV]	636
SV Sensor supply	5062 [mV]	5021
P3205: Primary analogue sensor max left position	429 [mV]	436
P3207: Primary analogue sensor max right position	4521 [mV]	4488
P3209: Primary analogue sensor neutral position	2513 [mV]	2507
P3217: SV sensor supply for primary analogue sensor during calibration	5061 [mV]	5021
P3211: Redundant analogue sensor max left position	427 [mV]	435
P3213: Redundant analogue sensor max right position	4521 [mV]	4491
P3215: Redundant analogue sensor neutral position	2518 [mV]	2509
P3219: SV sensor supply for redundant analogue sensor during calibration	5061 [mV]	5021
P3185: WAS max left position (CAN)	800 [mV]	800
P3187: WAS max right position (CAN)	4500 [mV]	4500
P3189: WAS neutral position (CAN)	2500 [mV]	2500
P3191: Automatically adjusted cylinder stroke volume (CAN WAS)	6535 [ccm]	6535
P3193: Automatically adjusted maximum steer angle to left side (CAN WAS)	6535 [deg]	6535
P3195: Automatically adjusted maximum steer angle to right side (CAN WAS)	6535 [deg]	6535
P3221: Automatically adjusted cylinder stroke volume (analogue WAS)	6535 [ccm]	6535
P3223: Automatically adjusted maximum steer angle to left side (analogue WAS)	6535 [deg]	6535
P3225: Automatically adjusted maximum steer angle to right side (analogue WAS)	6535 [deg]	6535

Figure 30

When all three measurements have been captured, press “Accept and Save”. PVED-CLS will now store the values in the EEPROM for the following addresses:



Name	Address	Data type	Unit	Description of parameter	User	Range		Danfoss default value	Safety critical parameters 'S'
						Min.	Max.		
Primary analogue sensor max left position	P3205	U16	mVolts	Primary analogue sensor voltage output for leftmost position	OEM, Dealer	0	6000	500	
Primary analogue sensor max right position	P3207	U16	mVolts	Primary analogue sensor voltage output for rightmost position	OEM, Dealer	0	6000	4500	
Primary analogue sensor neutral position	P3209	U16	mVolts	Primary analogue sensor voltage output for neutral position	OEM, Dealer	0	6000	2500	
Redundant analogue sensor max left position	P3211	U16	mVolts	Redundant analogue sensor voltage output for leftmost position	OEM, Dealer	0	6000	500	
Redundant analogue sensor max right position	P3213	U16	mVolts	Redundant analogue sensor voltage output for rightmost position	OEM, Dealer	0	6000	4500	
Redundant analogue sensor neutral position	P3215	U16	mVolts	Redundant analogue sensor voltage output for neutral position	OEM, Dealer	0	6000	2500	
5V sensor supply for primary analogue sensor during calibration	P3217	U16	mVolts	Measured Supply voltage during calibration of the primary analogue sensor	OEM, Dealer	4650	5350	5000	
5V sensor supply for redundant analogue sensor during calibration	P3219	U16	mVolts	Measured Supply voltage during calibration of the redundant analogue sensor	OEM, Dealer	4650	5350	5000	
Automatically adjusted cylinder stroke volume (CAN WAS)	P3191	U16	ccm	Automatically adjusted cylinder stroke volume, for using CAN WAS, found during WAS auto-calibration	OEM, Dealer	100	65535	65535	
Automatically adjusted maximum steer angle to left side (CAN WAS)	P3193	U16	Deg	Automatically adjusted maximum steer angle to left side, for using CAN WAS, found during WAS auto-calibration	OEM, Dealer	0	65535	65535	
Automatically adjusted maximum steer angle to right side (CAN WAS)	P3195	U16	Deg	Automatically adjusted maximum steer angle to right side, for using CAN WAS, found during WAS auto-calibration	OEM, Dealer	0	65535	65535	
Automatically adjusted cylinder stroke volume (analogue WAS)	P3221	U16	ccm	Automatically adjusted cylinder stroke volume, for using analogue WAS, found during WAS auto-calibration	OEM, Dealer	100	65535	65535	
Automatically adjusted maximum steer angle to left side (analogue WAS)	P3223	U16	Deg	Automatically adjusted maximum steer angle to left side, for using analogue WAS, found during WAS auto-calibration	OEM, Dealer	0	65535	65535	
Automatically adjusted maximum steer angle to right side (analogue WAS)	P3225	U16	Deg	Automatically adjusted maximum steer angle to right side, for using analogue WAS, found during WAS auto-calibration	OEM, Dealer	0	65535	65535	

Table 31

Or

Name	Address	Data type	Unit	Description of parameter	User	Range		Danfoss default value	Safety critical parameters 'S'
						Min.	Max.		
WAS max left position (CAN)	P3185	U16	mVolts	Wheel angle sensor voltage output for leftmost position over CAN	OEM, Dealer	0	5000	500	
WAS max right position (CAN)	P3187	U16	mVolts	Wheel angle sensor voltage output for rightmost position over CAN	OEM, Dealer	0	5000	4500	
WAS neutral position (CAN)	P3189	U16	mVolts	Wheel angle sensor voltage output for neutral position over CAN	OEM, Dealer	0	5000	2500	

Table 32

Important



If WAS interface is selected as NONE then WAS auto-calibration cannot be performed.

WAS Calibration

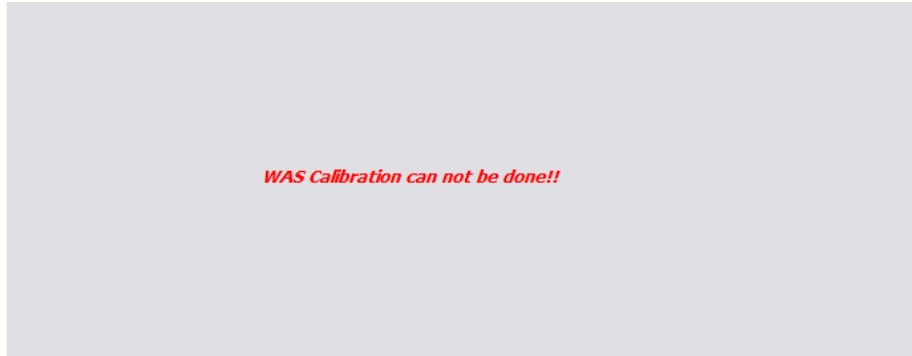

Figure 31

9.5.3 Execute Analogue Joystick auto-calibration from the PLUS+1 SERVICE TOOL

In the navigation pane, find “Parameter Pages” → “Auto-Calibration” → “Joystick Calibration”

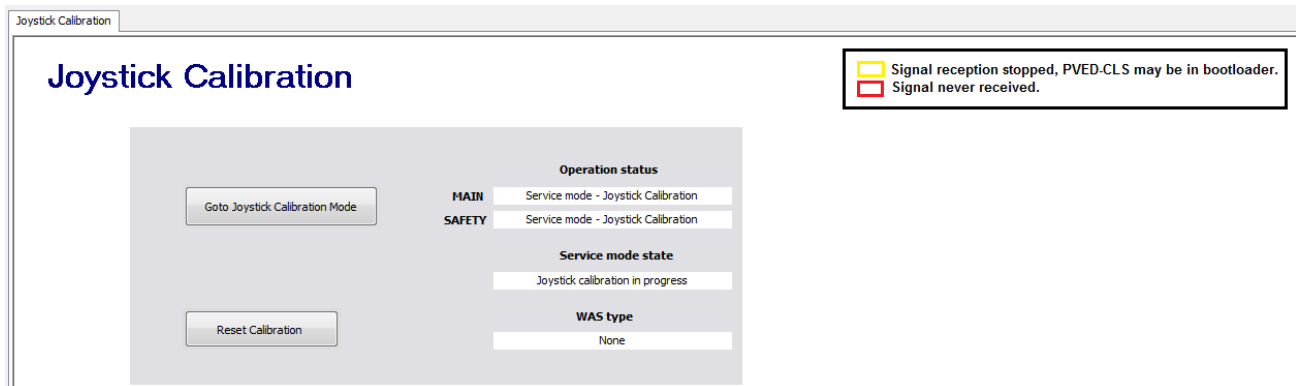

Figure 32



Press “Goto Joystick Calibration Mode”. Now the leftmost, rightmost and neutral position can be captured, simply by steer the Joystick fully left, fully right and back to neutral and press the capture buttons (Capture L, Capture N and Capture R) respectively. It does not matter in which sequence this is done. Danfoss recommends to capture neutral position while driving the vehicle slowly, aiming at a spot far away.

Goto Joystick Calibration Mode

Reset Calibration

Operation status

MAIN Service mode - Joystick Calibration

SAFETY Service mode - Joystick Calibration

Service mode state

Joystick calibration in progress

WAS type

None

	MAIN		SAFETY
Primary WAS	2493	[mV]	2481
Redundant WAS	2492	[mV]	2484
5V Sensor supply	5061	[mV]	5020

Capture L

Capture N

Capture R

	MAIN		SAFETY
Primary WAS	688	[mV]	693
Redundant WAS	686	[mV]	695
5V Sensor supply	5063	[mV]	5020
P3791: Max allowable Analogue Sensor signal to be captured in Neutral	0 4 5 0 0	[mV]	0 4 5 0 0
P3793: Min voltage needed in between the captured Analogue Sensor values	0 0 0 0 0	[mV]	0 0 0 0 0
P3795: Min allowable Analogue sensor signal to be captured in Neutral	0 0 5 0 0	[mV]	0 0 5 0 0

Accept and Save

Figure 33



Whenever one of the capture-buttons has been pushed, a green bar will light up beneath it.

Operation status

MAIN Service mode - Joystick Calibration

SAFETY Service mode - Joystick Calibration

Service mode state

Joystick calibration complete

WAS type

None

Goto Joystick Calibration Mode

Reset Calibration

MAIN **SAFETY**

Primary WAS [mV]

Redundant WAS [mV]

5V Sensor supply [mV]



Capture L

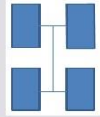

Capture N



Capture R

MAIN **SAFETY** **MAIN** **SAFETY** **MAIN** **SAFETY**

Primary WAS [mV] [mV] [mV]

Redundant WAS [mV] [mV] [mV]

5V Sensor supply [mV]

P3791: Max allowable Analogue Sensor signal to be captured in Neutral [mV]

P3793: Min voltage needed in between the captured Analogue Sensor values [mV]

P3795: Min allowable Analogue sensor signal to be captured in Neutral [mV]

New parameter values in the EEPROM

Read Data

MAIN **SAFETY**

Analog Sensor calibration data

Primary WAS

P3205 : Primary analogue sensor max left position [mV]

P3207 : Primary analogue sensor max right position [mV]

P3209 : Primary analogue sensor neutral position [mV]

P3217 : 5V sensor supply for primary analogue sensor during calibration [mV]

Redundant WAS

P3211 : Redundant analogue sensor max left position [mV]

P3213 : Redundant analogue sensor max right position [mV]

P3215 : Redundant analogue sensor neutral position [mV]

P3219 : 5V sensor supply for redundant analogue sensor during calibration [mV]

Accept and Save

Figure 34



When all three measurements have been captured, press “Accept and Save”. PVED-CLS will now store the values in the EEPROM for the following addresses:

Name	Address	Data type	Unit	Description of parameter	User	Range		Danfoss default value	Safety critical parameters ‘S’
						Min.	Max.		
Primary analogue sensor max left position	P3205	U16	mVolts	Primary analogue sensor voltage output for leftmost position	OEM, Dealer	0	6000	500	
Primary analogue sensor max right position	P3207	U16	mVolts	Primary analogue sensor voltage output for rightmost position	OEM, Dealer	0	6000	4500	
Primary analogue sensor neutral position	P3209	U16	mVolts	Primary analogue sensor voltage output for neutral position	OEM, Dealer	0	6000	2500	
Redundant analogue sensor max left position	P3211	U16	mVolts	Redundant analogue sensor voltage output for leftmost position	OEM, Dealer	0	6000	500	
Redundant analogue sensor max right position	P3213	U16	mVolts	Redundant analogue sensor voltage output for rightmost position	OEM, Dealer	0	6000	4500	
Redundant analogue sensor neutral position	P3215	U16	mVolts	Redundant analogue sensor voltage output for neutral position	OEM, Dealer	0	6000	2500	
5V sensor supply for primary analogue sensor during calibration	P3217	U16	mVolts	Measured Supply voltage during calibration of the primary analogue sensor	OEM, Dealer	4650	5350	5000	
5V sensor supply for redundant analogue sensor during calibration	P3219	U16	mVolts	Measured Supply voltage during calibration of the redundant analogue sensor	OEM, Dealer	4650	5350	5000	

Table 33

Important

If WAS interface is selected as Analogue then joystick calibration cannot be performed.

Joystick Calibration

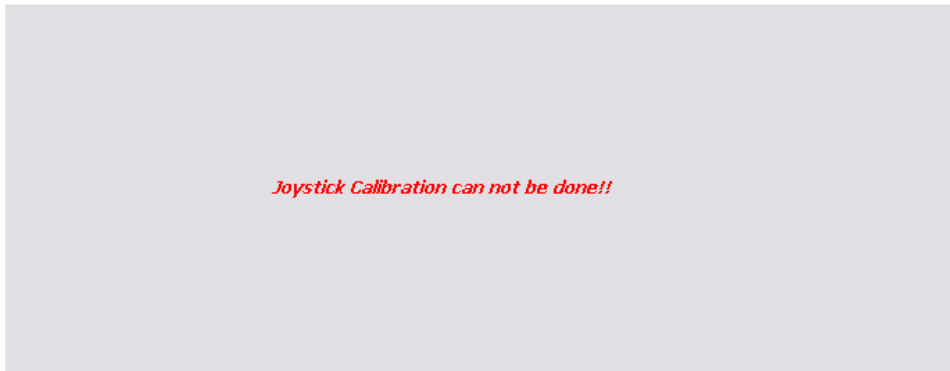

Figure 35



9.5.4 Execute spool auto-calibration from the PLUS+1 SERVICE TOOL

In the system navigator pane, find “Parameter pages” → “Auto-Calibration” → “Spool Calibration”

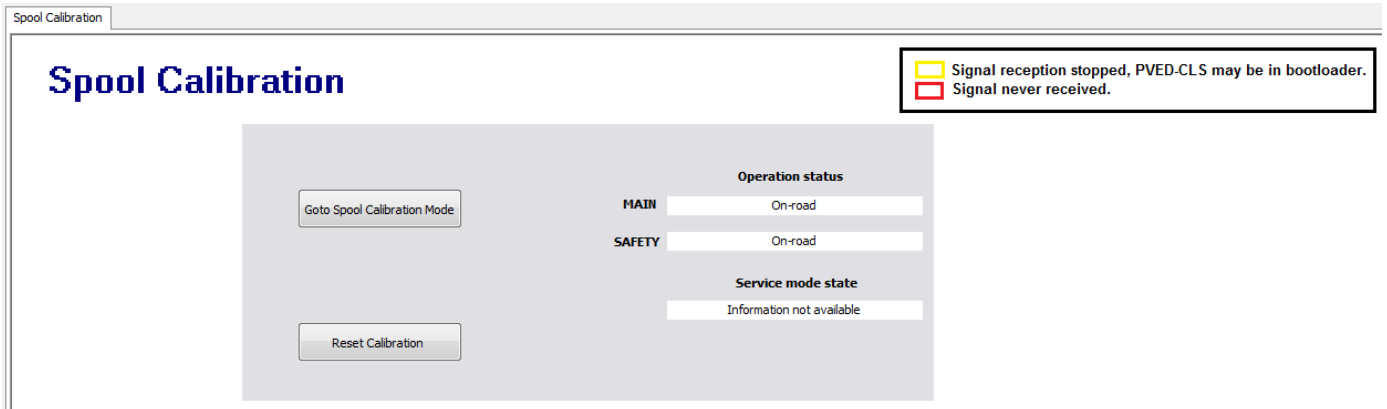

Figure 36

Press “Goto Spool Calibration Mode”.

Important

Before pressing the “Start spool calibration”-button, the steering has to be activated otherwise it will not engage the spool calibration. See description for P3801 in section 9.4.1.1

Important

*The wheels of the machine need to be in a straight-ahead position (within value for **Spool calibration - +/- turn range sweep**; P3804), in order to start the spool auto-calibration routine.*



Now the spool calibration can be started with the values stored in the EEPROM (P3797 – P3811), simply by pressing the “Start spool calibration” button.

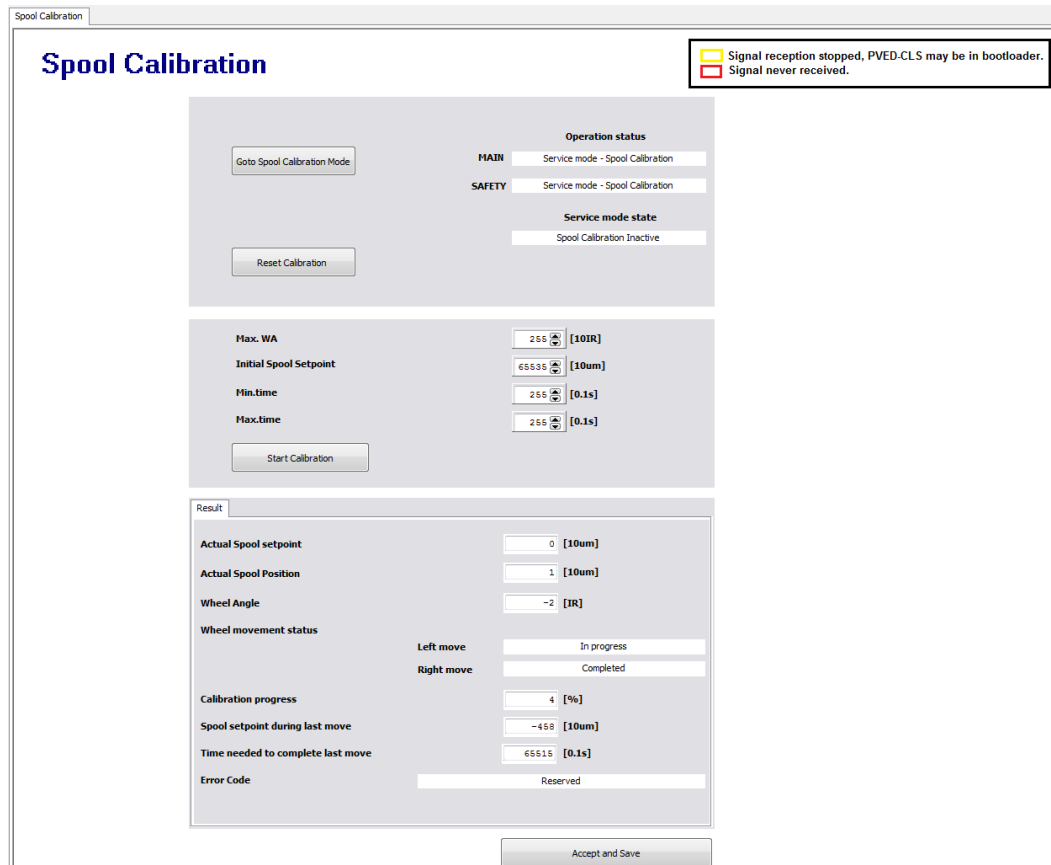



Figure 37

The 4 parameters listed below have the following values per default (in hex 0xFF, 0xFFFF, 0xFF, 0xFF):

- “Max. WA” = 255 [10IR]
- “Initial Spool Set-point” = 65535 [10µm]
- “Min. time” = 255 [0.1s]
- “Max. time” = 255 [0.1s]

The above only means that the default values from the EEPROM are used. If these 4 parameters are changed (by typing a different value or using the increase/decrease-buttons “”), the new values will be used for the auto-calibration function.



Spool Calibration

Spool Calibration

■ Signal reception stopped, PVED.CLS may be in bootloader.
■ Signal never received.

Operation status

MAIN Service mode - Spool Calibration

SAFETY Service mode - Spool Calibration

Service mode state

Spool Calibration Complete

Max. WA [10IR]

Initial Spool Setpoint [10um]

Min.time [0.1s]

Max.time [0.1s]

Result

Actual Spool setpoint [10um]

Actual Spool Position [10um]

Wheel Angle [IR]

Wheel movement status

Left move	Completed
Right move	Information not available

Calibration progress [%]

Spool setpoint during last move [10um]

Time needed to complete last move [0.1s]

Error Code

New parameter values in the EEPROM

	MAIN	SAFETY
P3162 : Leftmost position	<input type="text" value="-420"/> [10um]	<input type="text" value="-420"/>
P3164 : Rightmost position	<input type="text" value="420"/> [10um]	<input type="text" value="420"/>
Closed Loop deadband		
P3166 : Left deadband edge	<input type="text" value="-158"/> [10um]	<input type="text" value="-158"/>
P3168 : Right deadband edge	<input type="text" value="146"/> [10um]	<input type="text" value="146"/>
P3170 : Deadband offset	<input type="text" value="15"/> [10um]	<input type="text" value="15"/>

Figure 38

When a successful spool calibration has been achieved, press “Accept and Save” button. PVED-CLS will now store the values in the EEPROM for the following addresses:

Name	Address	Data type	Unit	Description of parameter	User	Range		Danfoss default value	Safety critical parameters ‘S’
						Min.	Max.		
Max spool position, left	P3162	S16	x10u Meter	Spool left most position	OEM, Dealer	-1000	1000	-420	
Max spool position, right	P3164	S16	x10u Meter	Spool right most position	OEM, Dealer	-1000	1000	420	
Closed loop dead-band edge, left	P3166	S16	x10u Meter	Spool closed loop dead-band edge, Left	OEM, Dealer	-1000	1000	-105	
Closed loop dead-band edge, right	P3168	S16	x10u Meter	Spool closed loop dead-band edge, Right	OEM, Dealer	-1000	1000	105	
Open loop dead-band edge offset	P3170	S16	x10u Meter	Spool open loop dead-band offset	OEM, Dealer	-1000	1000	25	

Table 34



Updating Valve Calibration Data sector manually and by auto-calibration function:

Changing parameters P3162, P3164, P3170 in the valve calibration sector can be done in two ways, depending on the configuration tool capability and the access authority of the requestor.

1) Manual Valve Calibration Data sector modification

The valve calibration sector is modified by:

- Reading out the sector values
- Modifying the parameters subject to changes
- Calculate a new sector CRC
- Write the modified sector, sector CRC and signature CRC to the PVED-CLS

The PVED-CLS will apply the calibration values directly after re-start.

The advantage is that changes can be made to the sector without enforcing a subsequent auto-calibration procedure for the change to take effect.

Important

*This strategy requires using manual modification of the following parameters:
P3091 set to 0, P3093 set to 0 and P3095 set to 0, which are the default values.*

2) Automatic Valve Calibration Data sector modification

In situations where it is not desired that the service tool shall read sector values and calculate new CRC values after modification, the Automatic Valve Calibration sector modification can be employed.

To use this method the desired parameter changes to P3162, P3164 and P3170 in the valve calibration sector is configured in the hydraulic configuration sector.

The PVED-CLS spool auto-calibration routine will copy P3091, P3093 and P3095 to P3162, P3164 and P3170, respectively and calculate the Valve Calibration Data sector CRC.

The advantage is that a change to the valve calibration sector can be effectuated by updating the hydraulic configuration sector with a pre-calculated sector CRC and signature CRC.

Important

A spool auto-calibration must be executed for effectuating the change in the Valve Calibration Data sector.

In this case the below parameters shall be configured (shown with default values).

P3091 set to -420 for OSPE/EHi or -700 for EHPS, P3093 set to 420 for OSPE/EHi or 700 for EHPS and P3095 set to 25.

9.5.4.1 Fine-tuning of parameters for spool calibration

The following parameters can be tuned when the calibrated dead-band values give, either in Auto-guidance or Fast-steering mode, a sluggish steering behavior, aggressive steering behavior or simply if the total calibration time is too time-consuming.

- Sluggish steering behavior after successful dead-band calibration**
 The operator should try with a smaller time frame (P3806 and P3808 should be decreased) and the measured wheel angle distance should be increased (P3804).
- Aggressive steering behavior after successful dead-band calibration**
 The operator should try with a larger time frame (P3806 and P3808 should be increased) and the measured wheel angle distance should be decreased (P3804).
- Total spool calibration time is to long**
 The operator should try with a lower vector combination (P3810 and P3811 should be decreased) and the time frame (delta between P3806 and P3808) and measure wheel angle distance (P3804) should be decreased percentage-wise, equally.

Important

If WAS interface is selected as NONE then Spool auto-calibration cannot be performed.

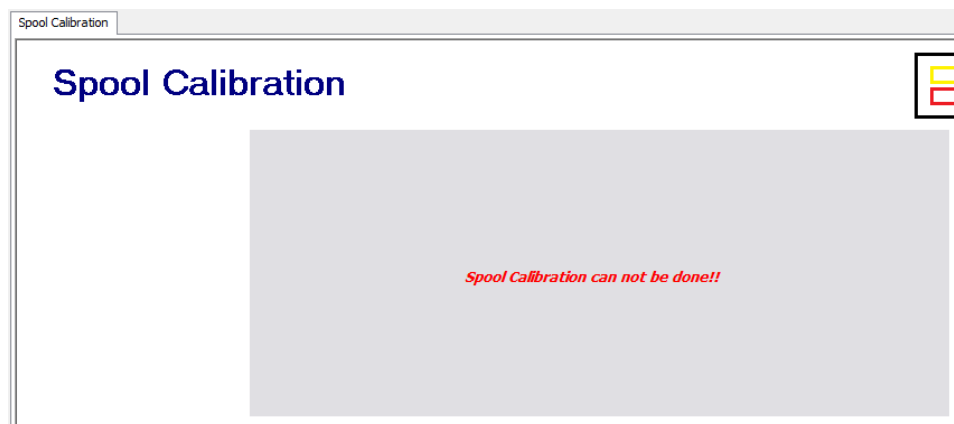

Figure 39



10 Steering wheel programs

When the PVED-CLS is in Off-road steering mode, one of the 5 different programs can be chosen which can be set with some individual parameters for the steering ratio, and some parameters which are common for all 5 programs such as soft-stop, anti-jerk etc. Furthermore, if the an OSPE/EHi-E system is being used and the OSP steering unit is specified as an LSRM-type (see OSPE Steering valve, Technical information), then either Off-road reaction or Off-road non-reaction can be chosen.

10.1 BLOCK DIAGRAM

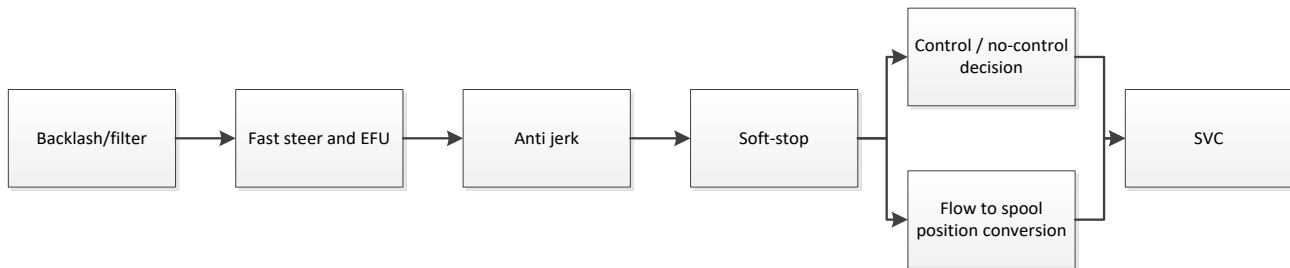

Figure 40

10.2 BACKLASH

If the neutral springs in the OSP affect the SASAID sensor readings when the driver releases the steering wheel and hereby unintentionally operates the valve, a backlash region (P3570) can be applied to prevent it. The size of the backlash region is normally set equal to the angle related to response. However, any set-value greater than zero leads to slower steering responds. Therefore, to minimize these effects, the steering wheel, sensor shaft and underlying mechanics must be designed as stiff as possible.

Since this parameter only affects changes in the set-point, stability problems in closed loop are not related to the set-value of this parameter.

The value recommended by Danfoss, which is 0.5 Deg., i.e. P3570 set to 5, does not remove elasticity effects.

Important

Setting this value higher than the recommended value, could lead to slow steering response

Name	Address	Data type	Unit	Description of parameter	User	Range		Danfoss default value	Safety critical parameters 'S'
						Min.	Max.		
Backlash region	P3570	U8	dDeg	Backlash limit to use in the backlash filter in the steering wheel control algorithm Resolution: 1dDeg = 0.1Deg	OEM	0	200	5	

Table 35



10.3 STW IN USE AND ACTIVATION THRESHOLD

A steering wheel signal filter has been applied to the PVED-CLS’s steering wheel control algorithm, as a part of risk mitigation, to avoid unintended spool actuation, etc. when driving on bumpy-ground.

Practically, any steering wheel signals, i.e. steering wheel signal where the steering angle velocity is below the value in P3521, will be disregarded.

Furthermore, any other steering devices can be disengaged and returned back to STW mode (only hydraulic steering) by activating/turning the steering wheel. In OSPE, EHi-E and EHPS system, the PVED-CLS detects that the steering wheel is in use when both the threshold P3583 and P3584 are being exceeded. Transition to the Auto-guidance or AUX program is allowed if steering wheel velocity is lower than STW in use – velocity threshold i.e. P3583. To disengage auto-guidance or AUX program, both the steering wheel velocity and steering wheel position change shall exceed the values in P3583 and 3584 respectively. (In EHI-H system, the disengage is performed by IMD function unlike above function)

Name	Address	Data type	Unit	Description of parameter	User	Range		Danfoss default value	Safety critical parameters ‘S’
						Min.	Max.		
STW - Steering wheel no-activation threshold	P3521	U8	dRpm	Min steering angle velocity value below which the angle velocity of 0 is used by the STW control algorithm	OEM	0	100	5	
STW in use - Velocity threshold	P3583	U8	dRpm	Steering wheel velocity threshold	OEM	1	100	5	S
STW in use - Angle threshold	P3584	U8	Deg	Steering wheel position change threshold, from last detected position at 0 RPM	OEM	0	45	10	S

Table 36

10.4 VEHICLE SPEED DEPENDENT FAST-STEERING

The PVED-CLS has 5 different steering wheel programs, where the wanted number of turns lock-to-lock can be set up, on the steering wheel at a given vehicle speed (i.e. “Fast-steering”). Fast Steering is possible only in OSPE, EHi-E, EHPS with SASA sensor.

The range is from 1 to 100 km/h for the parameters named “Steering wheel program 1,2,3,4,5 - Vehicle speed @ Point B,C” and from 10 to 800 dec [Resolution = 0.01; 1turn = 100] for parameters named “Steering wheel program 1,2,3,4,5 – No of turns @ Point A,B,C”.

These parameters represent the three points on the curve below (Point A, B and C). The steering wheel control algorithm will make linear interpolation in between each of the three points. It is allowed to move these three points in any direction, limited by the following rules:

- Point A is always specified at Vehicle speed = 0 km/h
- Point C “No of turns” is valid for Point C “Vehicle speed” and vehicle speeds above Point C “Vehicle speed”
- Point A “No of turns” ≤ Point B “No of turns” ≤ Point C “No of turns”
- Point C “Vehicle speed” > Point B “Vehicle speed” > Point A “Vehicle speed”

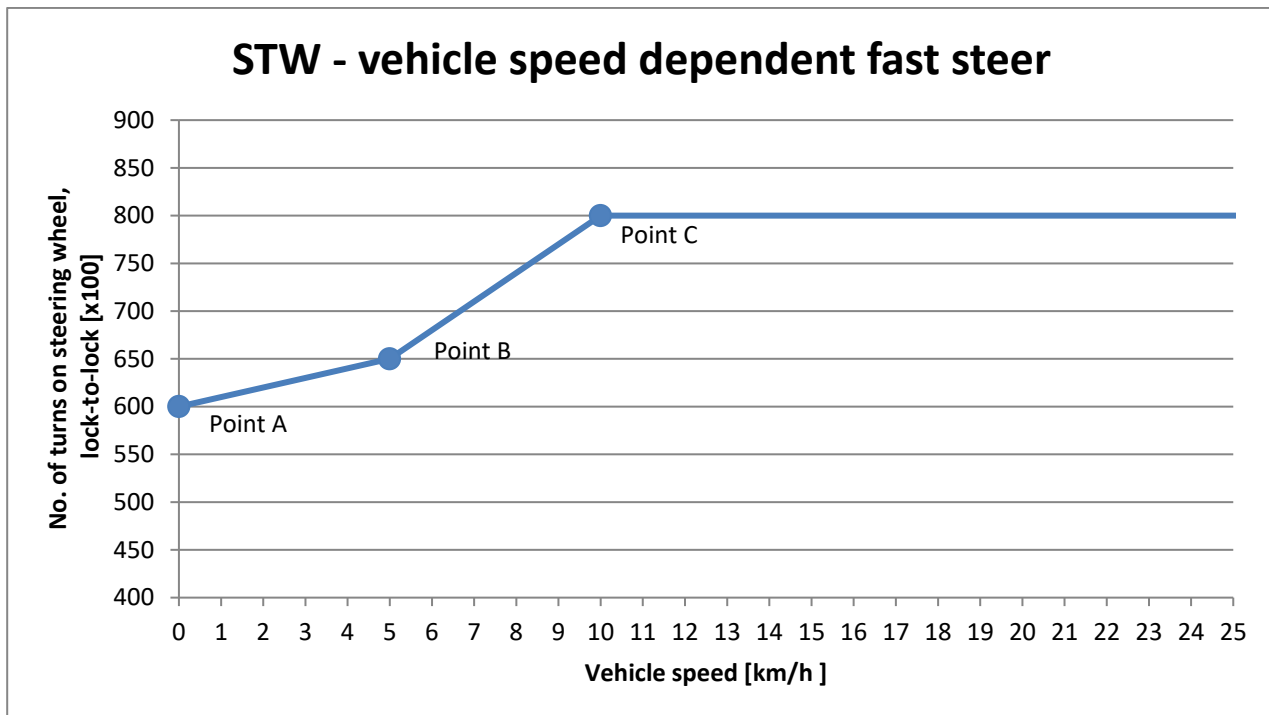

Figure 41

Important

For OSPE/EHi; even though it will be possible to set a value of “No of turns” up to 8 turns, lock-to-lock, this is limited by the Cylinder stroke volume; $P3086$ divided by OSP displacement, $P3084$. For EHPS, the limit will be the parameter; Turns lock-to-lock EHPS, $P3082$.

Warning

Danfoss strongly recommends that the Steering programs are set up to ensure safe operation at any vehicle speed. this implies that:

1. For every vehicle speed dependent steering program the configurable points shall result in a graph with positive slope.
2. If a steering program is configured not to be vehicle speed dependent, it must be ensured that the configuration allows safe driving at all possible vehicle speeds.
3. Unused steering programs shall be programmed with default values.

Failure to comply with the above rules may render this function inoperable or lead to undesirable steering behavior!



10.4.1 Compensate steering sensitivity according to wheel angle range

PVED-CLS offers a feature to keep the steering sensitivity fixed if the physical max wheel angle range is changed due to adding/changing tires.

The native steering program sensitivities for the steering programs are defined for the native physical wheel angle range at programming time. The native wheel angle range is set by the parameter, ‘Native wheel angle range for steering wheel programs’, P3585. The parameter shall not be modified unless new steering programs are created. This will ensure that the same aggressiveness in the steering system is maintained, even if the max angles change.

When the physical max wheel angle endpoints are changed by manual or WAS auto-calibration by one of the below conditions

- If WAS interface type in P3244 is selected as CAN and Automatic adjusted maximum steer angle to left side and right side, parameters P3193 and P3195 respectively, are changed OR
- If WAS interface type in P3244 is selected as Analogue WAS and Automatic adjusted maximum steer angle to left side and right side, parameters P3223 and P3225 respectively, are changed

Important

The programmed lock to lock ratio will not match the definition in EEPROM unless the actual wheel angle range matches ‘Native wheel angle range for steering wheel programs’.

Important

If steering sensitivity compensation is not required, the feature can be disabled by setting the parameter ‘Native wheel angle range for steering wheel programs’, P3585 to 0 deg or to a value equal to or larger than 179deg. Furthermore, if parameter ‘WAS Interface’ P3244, is configured to no wheel angle sensor present then this feature will be disabled.

Name	Address	Data type	Unit	Description of parameter	User	Range		Danfoss default value	Safety critical parameters ‘S’
						Min.	Max		
STW 1 - No of turns @ Point A	P3522	U16	-	Program1 - Number of steering wheel turns lock to lock at the vehicle speed of 0 km/h Resolution = 0.01; 1turn = 100	OEM	10	800	800	
STW 1 - No of turns @ Point B	P3524	U16	-	Program1 - Number of steering wheel turns lock to lock at the vehicle speed of "STW 1 - Vehicle speed @ Point B" Resolution = 0.01; 1turn = 100	OEM	10	800	800	
STW 1 - No of turns @ Point C	P3526	U16	-	Program1 - Number of steering wheel turns lock to lock at the vehicle speed of "STW 1 - Vehicle speed @ Point C" Resolution = 0.01; 1turn = 100	OEM	10	800	800	
STW 1 - Vehicle speed @ Point B	P3528	U8	km/h	Program1 - Vehicle speed at which lock to lock steering wheel turns = "STW 1 - No of turns @ Point B"	OEM	1	100	5	
STW 1 - Vehicle speed @ Point C	P3529	U8	km/h	Program1: Vehicle speed at which lock to lock steering wheel turns = "STW 1 - No of turns @ Point C"	OEM	1	100	10	
STW 2 - No of turns @ Point A	P3530	U16	-	Program2 - Number of steering wheel turns lock to lock at the vehicle speed of 0 km/h Resolution = 0.01; 1turn = 100	OEM	10	800	800	
STW 2 - No of turns @ Point B	P3532	U16	-	Program2 - Number of steering wheel turns lock to lock at the vehicle speed of "STW 2 - Vehicle speed @ Point B" Resolution = 0.01; 1turn = 100	OEM	10	800	800	



STW 2 - No of turns @ Point C	P3534	U16	-	Program2 - Number of steering wheel turns lock to lock at the vehicle speed of "STW 2 - Vehicle speed @ Point C" Resolution = 0.01; Iturn = 100	OEM	10	800	800	
STW 2 - Vehicle speed @ Point B	P3536	U8	km/h	Program2 - Vehicle speed at which lock to lock steering wheel turns = "STW 2 - No of turns @ Point B"	OEM	1	100	5	
STW 2 - Vehicle speed @ Point C	P3537	U8	km/h	Program2: Vehicle speed at which lock to lock steering wheel turns = "STW 2 - No of turns @ Point C"	OEM	1	100	10	
STW 3 - No of turns @ Point A	P3538	U16	-	Program3 - Number of steering wheel turns lock to lock at the vehicle speed of 0 km/h Resolution = 0.01; Iturn = 100	OEM	10	800	800	
STW 3 - No of turns @ Point B	P3540	U16	-	Program3 - Number of steering wheel turns lock to lock at the vehicle speed of "STW 3 - Vehicle speed @ Point B" Resolution = 0.01; Iturn = 100	OEM	10	800	800	
STW 3 - No of turns @ Point C	P3542	U16	-	Program3 - Number of steering wheel turns lock to lock at the vehicle speed of "STW 3 - Vehicle speed @ Point C" Resolution = 0.01; Iturn = 100	OEM	10	800	800	
STW 3 - Vehicle speed @ Point B	P3544	U8	km/h	Program3 - Vehicle speed at which lock to lock steering wheel turns = "STW 3 - No of turns @ Point B"	OEM	1	100	5	
STW 3 - Vehicle speed @ Point C	P3545	U8	km/h	Program3: Vehicle speed at which lock to lock steering wheel turns = "STW 3 - No of turns @ Point C"	OEM	1	100	10	
STW 4 - No of turns @ Point A	P3546	U16	-	Program4 - Number of steering wheel turns lock to lock at the vehicle speed of 0 km/h Resolution = 0.01; Iturn = 100	OEM	10	800	800	
STW 4 - No of turns @ Point B	P3548	U16	-	Program4 - Number of steering wheel turns lock to lock at the vehicle speed of "STW 4 - Vehicle speed @ Point B" Resolution = 0.01; Iturn = 100	OEM	10	800	800	
STW 4 - No of turns @ Point C	P3550	U16	-	Program4 - Number of steering wheel turns lock to lock at the vehicle speed of "STW 4 - Vehicle speed @ Point C" Resolution = 0.01; Iturn = 100	OEM	10	800	800	
STW 4 - Vehicle speed @ Point B	P3552	U8	km/h	Program4 - Vehicle speed at which lock to lock steering wheel turns = "STW 4 - No of turns @ Point B"	OEM	1	100	5	
STW 4 - Vehicle speed @ Point C	P3553	U8	km/h	Program4: Vehicle speed at which lock to lock steering wheel turns = "STW 4 - No of turns @ Point C"	OEM	1	100	10	
STW 5 - No of turns @ Point A	P3554	U16	-	Program5 - Number of steering wheel turns lock to lock at the vehicle speed of 0 km/h Resolution = 0.01; Iturn = 100	OEM	10	800	800	
STW 5 - No of turns @ Point B	P3556	U16	-	Program5 - Number of steering wheel turns lock to lock at the vehicle speed of "STW 5 - Vehicle speed @ Point B" Resolution = 0.01; Iturn = 100	OEM	10	800	800	
STW 5 - No of turns @ Point C	P3558	U16	-	Program5 - Number of steering wheel turns lock to lock at the vehicle speed of "STW 5 - Vehicle speed @ Point C" Resolution = 0.01; Iturn = 100	OEM	10	800	800	
STW 5 - Vehicle speed @ Point B	P3560	U8	km/h	Program5 - Vehicle speed at which lock to lock steering wheel turns = "STW 5 - No of turns @ Point B"	OEM	1	100	5	
STW 5 - Vehicle speed @ Point C	P3561	U8	km/h	Program5: Vehicle speed at which lock to lock steering wheel turns = "STW 5 - No of turns @ Point C"	OEM	1	100	10	
Native wheel angle range for steering wheel programs	P3585	U8	deg	Lock to lock wheel angle range Used internally to maintain the steering sensitivity/aggressiveness when physical max wheel angle endpoints are changed	OEM	0	255	255	S

Table 37

10.5 ANTI-DRIFT (EFU)

The anti-drift function is implemented to eliminate drift in the steering wheel due to internal leakage and for having steering wheel in the same position, when driving straight ahead. The ideal output flow is calculated considering no drift in the steering wheel, however, if there is a drift in the steering wheel the function's control algorithm will calculate an anti-drift correction volume and determines the output flow (in ccm per revolution) by adding an anti-drift correction volume to the ideal output flow.

The anti-drift correction volume is calculated by looking at the difference, in degrees, measured at the steering wheel and the actual position of the wheels. How large a percentage of the full flow, the PVED-CLS's anti-drift algorithm will add, is defined by the following four points, Point A to Point D, where Point B and Point C are configurable.

- Point A (0, 0)
- Point B (P3568, P3569)
- Point C (160, P3569)
- Point D (0, 0)

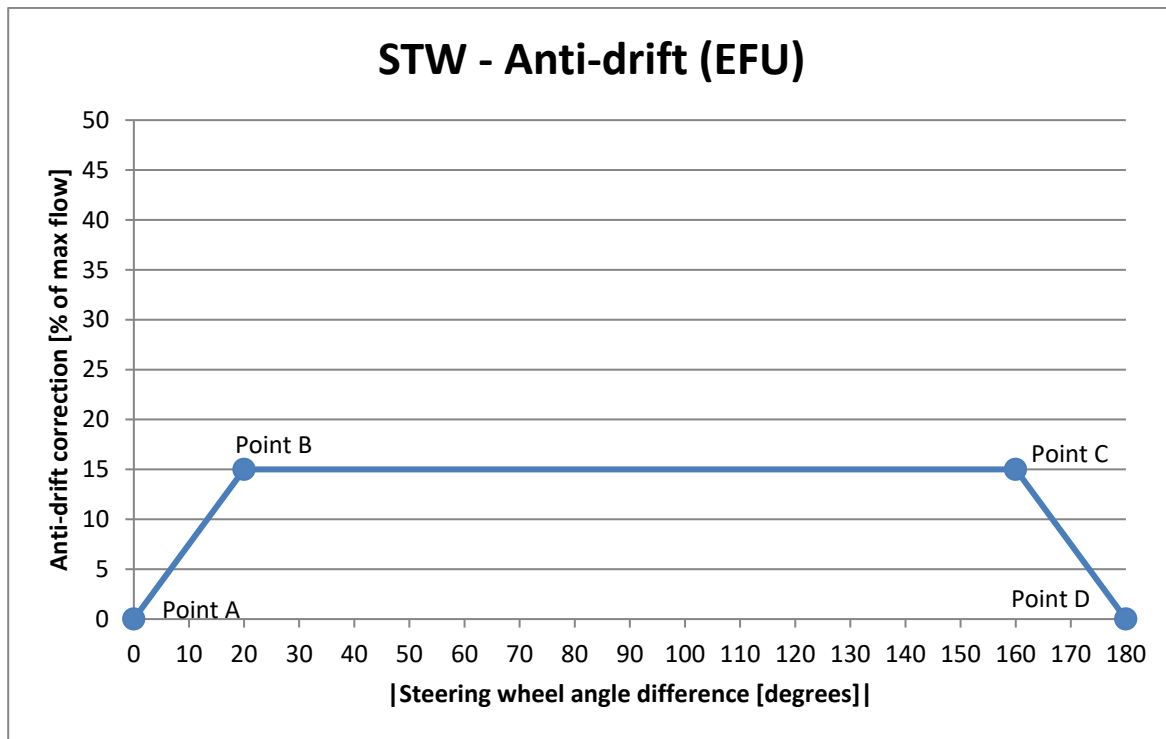

Figure 42

The range is from 1° to 160° for P3568, in steps of 1°. For P3569 the range goes from 0% to 100% in steps of 1%.

The values recommended by Danfoss are P3568 set to 20 and P3569 set to 15 i.e. anti-drift will be enabled all the time and 15% of the full flow will be added or deducted, depending on direction, to the calculated ideal ccm per revolution-output, when the difference between the measured steering wheel position and the actual position of the wheels is 20° - 160° (due to Point B and Point C’s coordinates). When steering wheel angle difference is > 160°, linear interpolation, between Point C and the fixed point D, will determine the anti-drift correction volume. Furthermore, anti-drift function will also improve consistency in lock-to-lock on steering wheel.

Important

If anti-drift is not required, the function can be disabled by setting P3569 to 0.

Name	Address	Data type	Unit	Description of parameter	User	Range		Danfoss default value	Safety critical parameters 'S'
						Min.	Max.		
STW anti-drift - Max steering wheel drift correction	P3568	U8	Deg	The difference between the observed and ideal STW steering angle at which and above which the max. EFU correction ("STW Anti-drift - Max flow correction") shall be applied.	OEM	1	160	20	
STW anti-drift - Max flow correction in percentage of full flow	P3569	U8	%	Max flow correction which can be requested by the EFU algorithm	OEM	0	100	15	

Table 38



10.6 ANTI-JERK

Jerk is a common unpleasant feeling/phenomenon, which can be experienced on large, articulated vehicles. To minimize these jerks, the PVED-CLS has a built-in anti-jerk algorithm which can be enabled and parameterized.

Briefly, the Anti-jerk algorithm has two sets of parameters to choose from, one set for when moving away from neutral position and one set for moving towards neutral position.

In the Figure below, point S1 shows the current spool position and S2 shows the calculated flow command to PVED-CLS. The point Sa1, Sa2 and Sa3 shows adjusted flow set-points after applying anti-jerk algorithm. When the spool is at point S1 and when there is jerk in the system, the flow set-point S2 is calculated and is expected to reach S2 in one cycle which is shown by dotted line (—) curve.

The anti-jerk algorithm calculates the ‘adjusted flow set-points’ Sa1, Sa2 and Sa3 based on relative or absolute set-point changes in one cycle i.e. in 10 ms which is shown by line (—) in Figure 43 and more smoother ramps will be applied to minimize the jerks in the system.

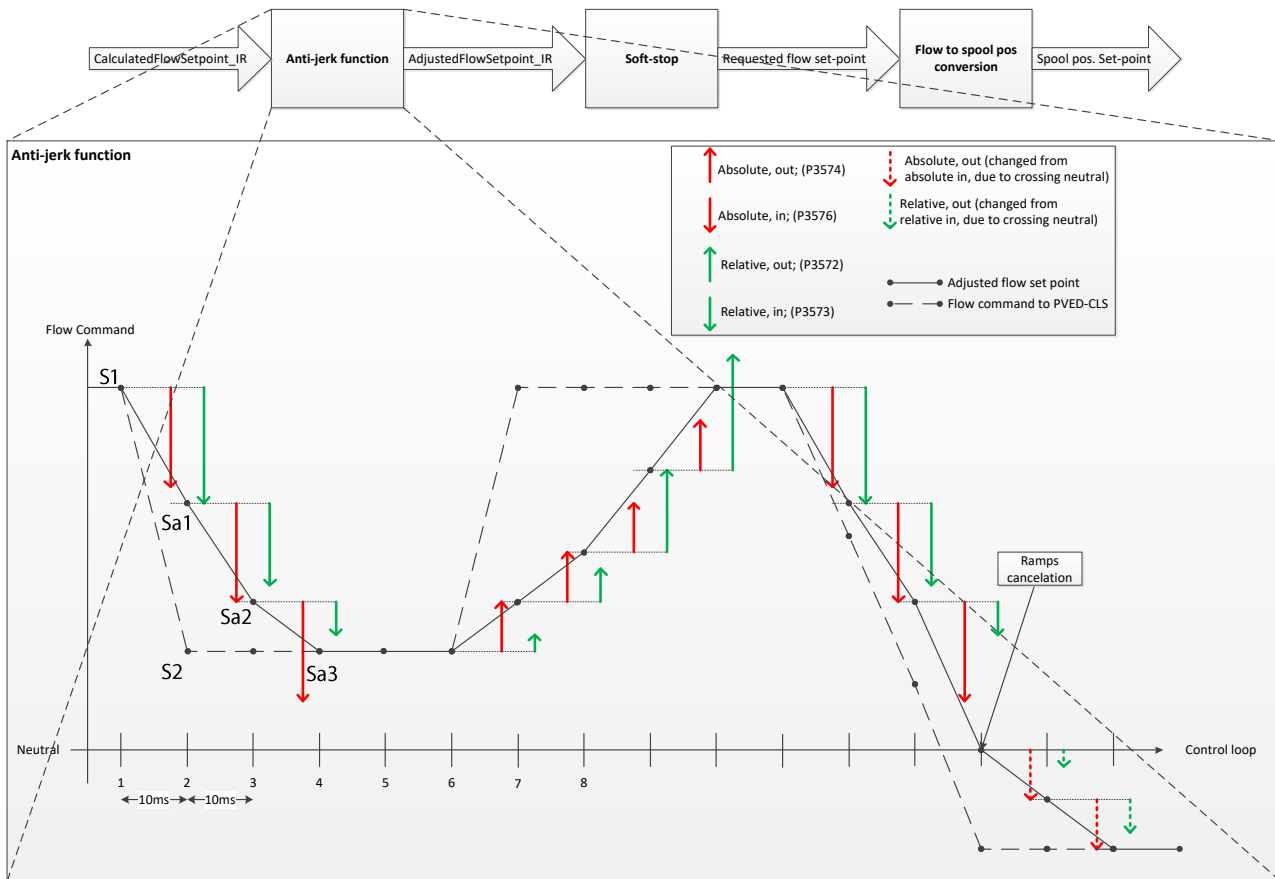

Figure 43



10.6.1 Calculation of flow set-point using anti-jerk functionality

The anti-jerk algorithm uses relative set-point parameters P3572 and P3573 in [%] and absolute set-point parameters P3734 and P3576 in [IR] and detects the relative or absolute set-point changes in one loop/cycle (10ms). The algorithm will choose the parameter (absolute or relative) which has the highest change of set-points for each loop (i.e. 10ms) and a new '*modified flow set-point*' is calculated. Finally, the low pass filter is applied on the '*modified flow set-point*' to calculate the '*filtered flow set-point*'.

The low pass filter in the function is configurable by P3582 (default cut-off frequency is 10Hz, i.e. P3582 set to 100).

If the EH-spool is commanded to go from left- to right-side or opposite, when crossing neutral, the ramps will be canceled and the parameter set will change from "*moving towards neutral position*" to "*moving away from neutral position*".

For the relative set-point parameters (P3572 and P3573), the value will change depending on the actual spool position. For the absolute set-point change parameters (P3574 and P3576), the value will always be a fixed set-point value, parameters shall be configured accordingly.

Important

An anti-jerk function is normally only used on articulated vehicles, where jerk is very common.

Important

Jerk is a sideways hard movement around the articulated point. This Anti-Jerk functionality will minimize the unpleasant sideways movement around the articulated point.

As an "on-the-top"-feature, further dampen of STW speed fluctuations can be done. So if the general STW Anti-jerk setup (P3571 to P3576) does not give the enough dampen/satisfying result, the anti-jerk on-the-top function can be enabled.

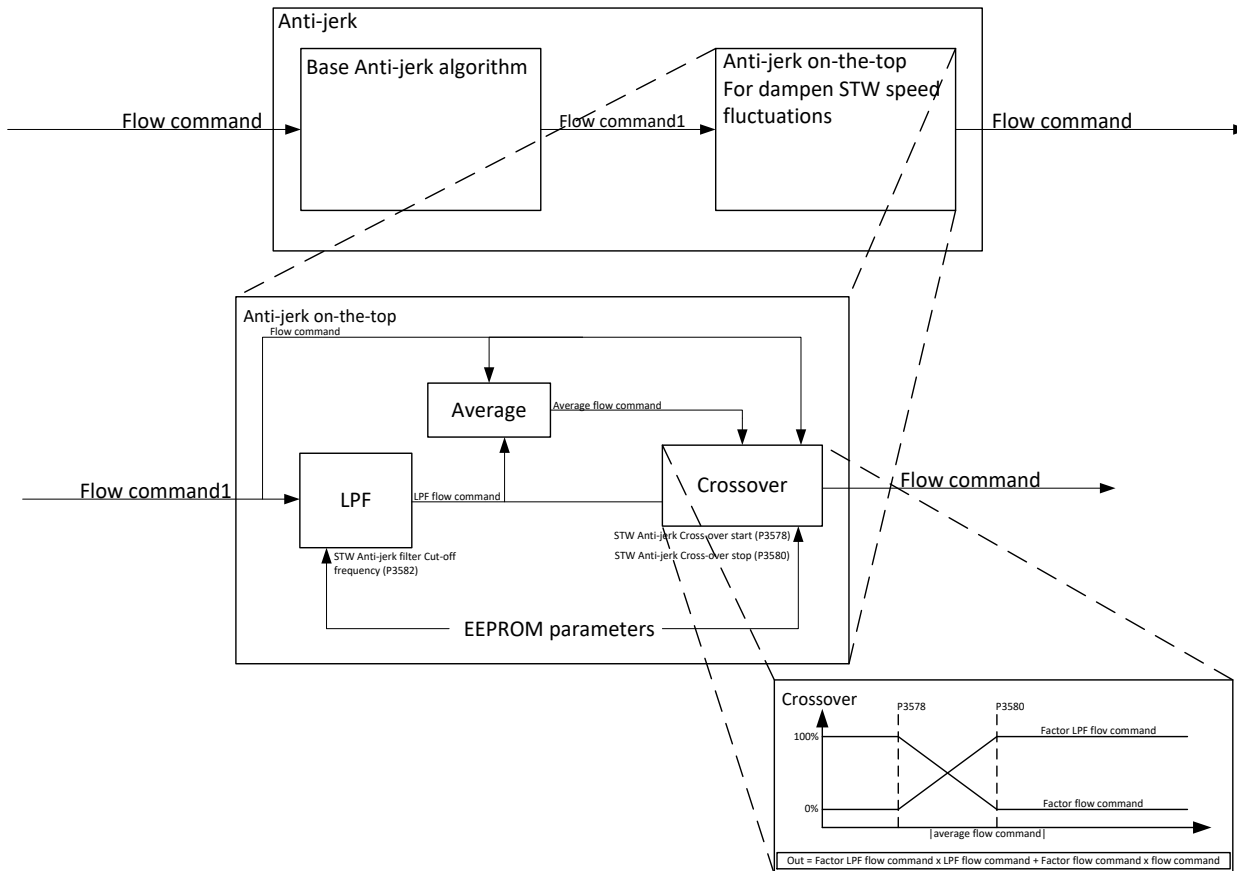

Figure 44

Referring to the Figure below, the ‘crossover/mixing factor’ in percentage is calculated and is applied on ‘Filtered flow set-point’ (see 10.6.1) to calculate the final ‘flow set-point’ of Anti-jerk algorithm.

Parameters P3578 and P3580 are used to calculate the percentage crossover to be applied on the ‘filtered flow set-point’ (see 10.6.1) to calculate the final ‘flow set-point’ with anti-jerk functionality.

The ‘Crossover/mixing factor’ is defined by the piece-wise linear characteristics based on following points in Figure 5. The absolute value of average flow set-point is calculated from ‘Modified Flow Set-point’ (see 10.6.1) and ‘Filtered Flow Set-point’ (see 10.6.1) in IR.

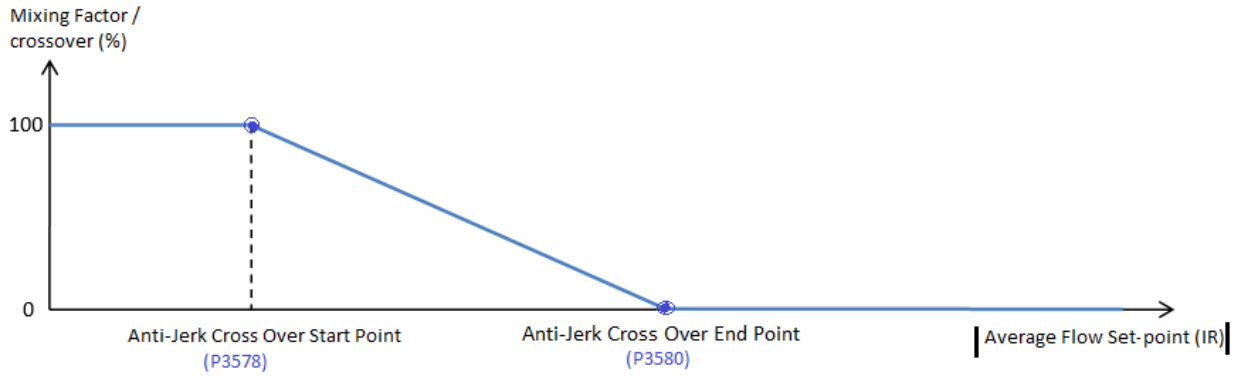

Figure 45

If P3578 is set to 1000 IR, the mixing factor 100 % will be considered for calculation of adjusted flow set-point.

As per default, P3578 and P3580 are both set to 10. Having both parameters set to the same value cancel out any crossover ramping. To enable the function, set P3578 and P3580 to a value between 0 and 1000 to indicate the crossover start (P3578) and crossover stop (P3580).

Name	Address	Data type	Unit	Description of parameter	User	Range		Danfoss default value	Safety critical parameters 'S'
						Min.	Max.		
STW anti-jerk function	P3571	U8	-	Defines the type of the anti-jerk functionality to use 0 for Anti Jerk type NONE and 1 for Anti Jerk type 1	OEM	0	1	0	
STW relative set-point change, out from spool neutral position	P3572	U8	%	Relative set-point change allowed to apply when ramping the spool position set-point out, i.e. further out from the spool neutral position [%]	OEM	0	100	5	
STW relative set-point change, in towards spool neutral position	P3573	U8	%	Relative set-point change allowed to apply when ramping the spool position set-point in, i.e. towards the spool neutral position [%]	OEM	0	100	5	
STW absolute set-point change, out from spool neutral position	P3574	U16	IR	Set-point change allowed to apply when ramping the spool position set-point out, i.e. further out from the spool neutral position	OEM	1	1000	15	
STW absolute set-point change, in towards spool neutral position	P3576	U16	IR	Set-point change allowed to apply when ramping the spool position set-point in, i.e. towards the spool neutral position	OEM	1	1000	10	
STW anti-jerk cross-over start point	P3578	U16	IR	STW Anti-jerk Cross-over start	OEM	0	1000	10	
STW anti-jerk cross-over stop point	P3580	U16	IR	STW Anti-jerk Cross-over stop	OEM	0	1000	10	
STW anti-jerk low pass filter cut-off frequency	P3582	U8	dHz	STW Anti-jerk low pass filter cut-off frequency Resolution: 1 dHz = 0.1 Hz	OEM	5	200	100	
STW in use - Velocity threshold	P3583	U8	dRpm	Steering wheel velocity threshold	OEM	1	100	5	S
STW in use - Angle threshold	P3584	U8	Deg	Steering wheel position change threshold, from last detected position at 0 RPM	OEM	0	45	10	S

Table 39



10.7 SOFT-STOP

The soft-stop function can limit the allowed maximum flow delivered to the steering cylinders in proportion to the relative wheel angle. The function is mirrored to both sides (left- and right-end stop). The functions control algorithm will implement a linear interpolation between two points, Point A and Point B.

- Point A (1000-P3562, 1000)
- Point B (1000-P3566, P3564)

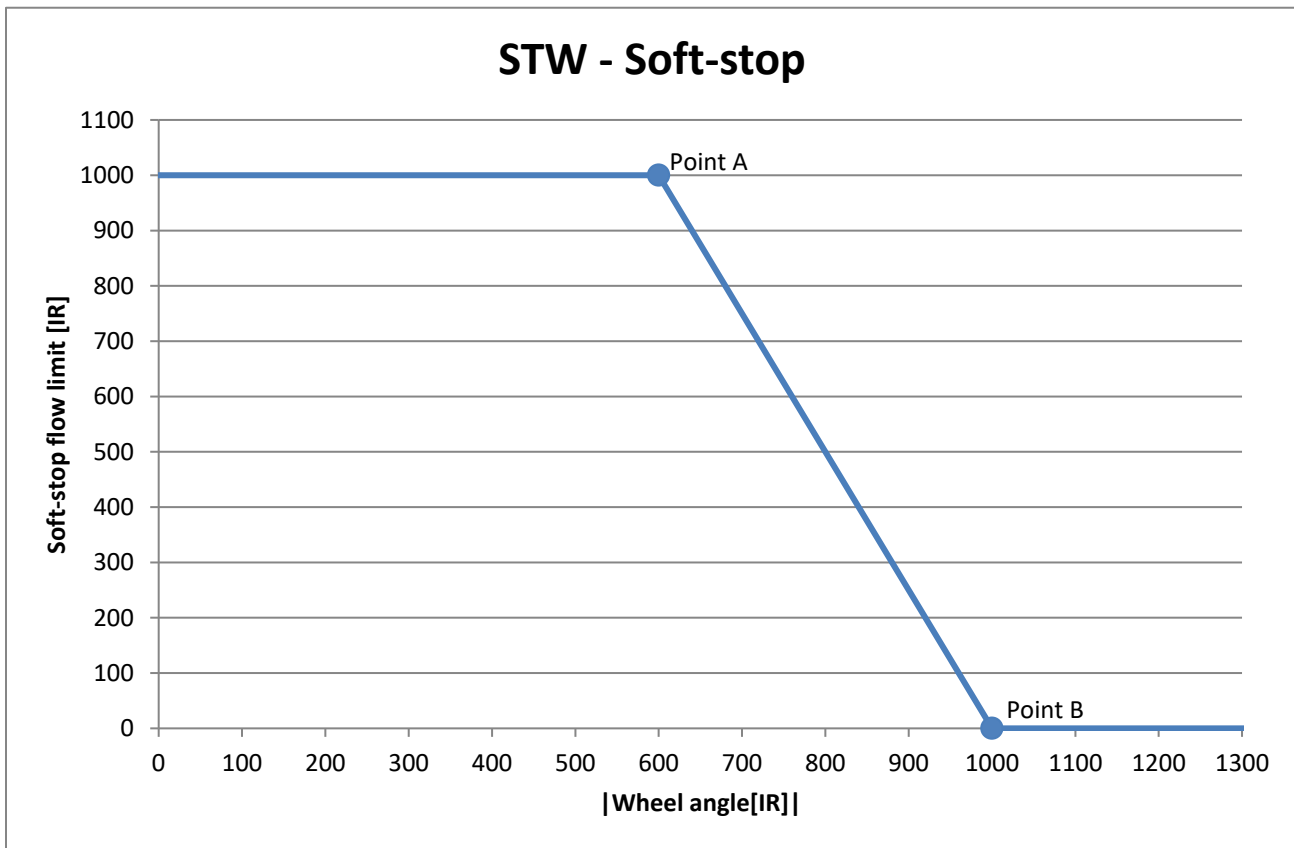

Figure 46

The range is from 0 to 1000 [IR] for P3562, P3564 and P3566 (i.e. relative wheel angle and soft-stop flow limit, respectively).

The values recommended by Danfoss are P3562 set to 400, and P3564 and P3566 set to 0.

Important

For absolute wheel angles lower than the one specified at Point A maximum flow is available.

Important

If soft-stops are not required, those can be eliminated by setting P3564 to 1000.



Name	Address	Data type	Unit	Description of parameter	User	Range		Danfoss default value	Safety critical parameters 'S'
						Min.	Max.		
STW soft-stop wheel angle region start	P3562	U16	IR	Defines the wheel angle region start, from the max possible wheel angle towards 0, in which the soft stop has to be applied	OEM	0	1000	400	
STW soft-stop max flow @ cylinder end-stop	P3564	U16	IR	Oil flow to deliver at the max possible wheel angle	OEM	0	1000	0	
STW soft-stop wheel angle region end	P3566	U16	IR	Defines the wheel angle region end, from the max possible wheel angle towards 0, in which the soft stop region shall end	OEM	0	1000	0	

Table 40



11 AUX steering

When the PVED-CLS is in off-road steering mode (see Figure) the following steering devices can be chosen: open loop mini wheel steering, open loop joystick steering or closed loop joystick steering.

Important

Only one type of AUX steering device can be present in the steering system at the same time. AUX steering device is selected by the parameter AUX type (P3240).

Important

Only one analogue input device can be present in the system. If a wheel angle sensor is wanted, in systems with an analogue joystick, the wheel angle sensor must be CAN based.

The PVED-CLS offers five different AUX open loop mini wheel steering programs, which can be setup with some individual parameters for the steering ratio. One AUX open loop joystick steering program can also be selected. The AUX open loop joystick steering program has its own individual speed dependent flow limit parameters. All AUX open loop steering programs share common parameters for soft-stop and anti-jerk.

The PVED-CLS offers one AUX closed loop joystick steering program. AUX closed loop joystick steering program has its own individual speed dependent wheel angle limit parameters.

Below Table 41, specifies the AUX steering options as per AUX Type parameter P3240.

AUX Steering device	CAN based – Danfoss proprietary protocol	Analogue – Two channel	Elobau® - Joystick series J4F with 351JCM
Open loop Joystick	Yes	Yes	Yes
Closed loop joystick	Yes	No	No
Mini-wheel	Yes	No	No

Table 41

11.1 BLOCK DIAGRAM

11.1.1 Open loop mini-wheel

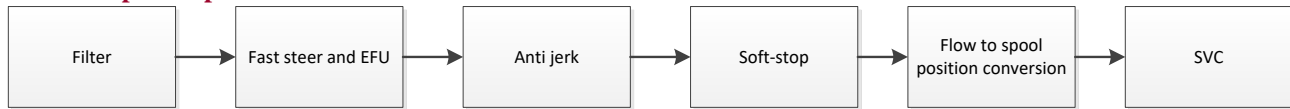

Figure 47

11.1.2 Open loop joystick



Figure 48

11.1.3 Closed loop joystick

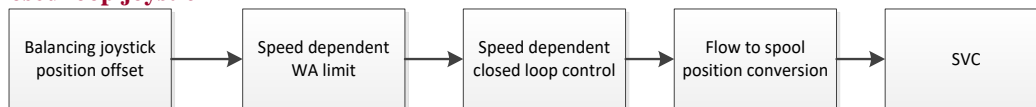

Figure 49

11.2 AUX CONFIG

Since the AUX functionality contains both mini wheel functionalities and joystick functionalities, the appropriate AUX functionality needs to be selected, by setting the parameter P3240.

When using auto-guidance functionality, a transition to AUX-program is performed by disengaging the auto-guidance functionality if:

11.2.1 AUX Joystick Config – Open Loop Mode

If the parameter P3240 is set to Analogue Joystick or open loop joystick or Elobau Joystick i.e. to function in open loop fashion. Then the PVED-CLS will perform a transition to AUX-program if the conditions specified in section 3.6.2 for ‘AUX open loop device’ are met and parameters for selected joystick type are configured correctly (Please see sections 11.8 and 11.9 for parameter configuration of analogue and open loop joystick and section 11.12.4 for elobau joystick).

Important

The system cannot contain two analogue sensors at the same time, meaning that WAS and Joystick cannot both be analogue in the same system hence if analogue joystick is selected then P3244, i.e. WAS Interface, must not be set to analogue.

11.2.2 AUX Joystick Config – Closed Loop Mode

To use the AUX steering device in close loop mode,

- The auxiliary steering device shall be present in the system i.e. parameter P3239 is set to TRUE and
- The auxiliary steering device is a closed loop joystick i.e. the parameter P3240 must be set to 1 and
- The auxiliary steering device is enabled in MMI messages (see PVED-CLS communication protocol for more details on MMI message) and



- The enable flag available in the AUX message-byte 5 is set to 01 (see PVED-CLS communication protocol for more details on AUX message) and
- The absolute value of the auxiliary steering device related closed loop error calculated by difference between calculated wheel angle set-point and actual wheel angle is less than or equal to the value specified by parameter P3732 i.e. *AUX joystick - Max closed loop error for engaging closed loop joystick steering*

If all these conditions are satisfied then the transition to AUX close loop mode is performed.

11.2.3 AUX Config – Mini-steering wheel

For mini-steering wheel, the PVED-CLS detects that the mini-steering wheel is used when both the threshold P3646 and P3719 are being exceeded, and will then perform a transition to AUX-program.

As a risk mitigation method, disengage the AUX-program and return to STW mode (only hydraulic steering or faststeering) is allowed by activating/turning the steering wheel. When driving off-road, e.g. on bumpy ground, too high sensitivity of the SASAIIID sensor may cause unintended disengage of AUX steering. In order to allow small movements of the steering wheel without disengaging the AUX-program, appropriate threshold values should be written in P3583 and P3584.

The PVED-CLS detects that the steering wheel is in use when both the threshold P3583 and P3584 are being exceeded. In order to allow the steering device change to AUX mini wheel, the steering wheel shall not be in use i.e. the absolute steering wheel velocity shall be lower than or equal to STW in use – Velocity threshold (P3583).

Important

The same “steering wheel in use”-algorithm is used for Auto-guidance-steering programs, hence the same rules are used to perform a transition to the Auto-guidance-program.

Name	Address	Data type	Unit	Description of parameter	User	Range		Danfoss default value	Safety critical parameters ‘S’
						Min.	Max.		
AUX type	P3240	U8	-	Aux device is mini steering wheel or Joystick Valid Values: 0 (Open Loop Joystick); 1 (Closed Loop Joystick); 2 (mini steering wheel); 3 (Analogue Joystick);20 (Elobau joystick)	OEM	0	20	2	
AUX mini-steering in use - Velocity threshold	P3646	U8	dRpm	AUX mini-steering velocity threshold to declare that the steering is in use	OEM	0	100	15	S
AUX joystick in use - Flow command threshold	P3647	U8	IR	AUX Joystick flow command threshold to declare that joystick is in use	OEM	0	100	10	S
STW in use - Velocity threshold	P3583	U8	dRpm	Steering wheel velocity threshold to detect steering is in use	OEM	1	100	5	S
STW in use - Angle threshold	P3584	U8	Deg	Steering wheel position change threshold, from last detected position at 0 RPM	OEM	0	45	10	S
AUX mini-steering in use - Angle threshold	P3719	U8	Deg	AUX mini-steering wheel angle change threshold to detect steering is in use	OEM	0	45	10	S

Table 43 (a)



11.3 OPEN LOOP FILTER

As a risk mitigation method, Danfoss wants to avoid unintended spool actuation, etc. when driving on bumpy-ground, therefore an open loop joystick and open loop mini-steering wheel signal filter has been applied to the PVED-CLS’s steering wheel control algorithm.

Practically, if open loop mini-steering wheel has been selected as steering type, any mini-steering wheel signals, i.e. where the steering angle velocity is below the value in P3649, will be disregarded.

Furthermore, if open loop joystick steering type has been selected, any joystick flow commands below the value in P3648 will be disregarded.

Name	Address	Data type	Unit	Description of parameter	User	Range		Danfoss default value	Safety critical parameters ‘S’
						Min.	Max.		
AUX – Joystick no-activation threshold	P3648	U8	IR	Min Flow command from AUX joystick below which the flow command of 0 is used by the AUX control algorithm	OEM	0	100	5	
AUX - Mini-steering no-activation threshold	P3649	U8	dRpm	Min AUX steering angle velocity value below which the angle velocity of 0 is used by the AUX control algorithm	OEM	0	100	5	

Table 42 (b)



11.4 OPEN LOOP MINI-WHEEL – VEHICLE SPEED DEPENDENT FAST-STEERING

The PVED-CLS has five different open loop mini-steering wheel programs, where the desired number of turns lock-to-lock on the mini-steering wheel at a given vehicle speed (i.e. “Fast-steering”) can be setup.

The range is from 1 to 100 km/h for the parameters named “AUX mini-steering 1,2,3,4,5 - Vehicle speed @ Point K,L” and from 10 to 800 dec [Resolution = 0.01; 1turn = 100] for parameters named “AUX mini-steering 1,2,3,4,5 - No of turns @ Point J,K,L”.

These parameters represent the three points on the Figure 50 (Point J, K and L). The Open Loop Mini-steering wheel control algorithm will make linear interpolation in between each of the three points. It is allowed to move the three points in any direction, limited by the following rules:

- Point J is always specified at Vehicle speed = 0 km/h
- Point L “No of turns” is valid for Point L “Vehicle speed” and vehicle speeds above Point L “Vehicle speed”
- Point J “No of turns” ≤ Point K “No of turns” ≤ Point L “No of turns”
- Point L “Vehicle speed” > Point K “Vehicle speed” > Point J “Vehicle speed”

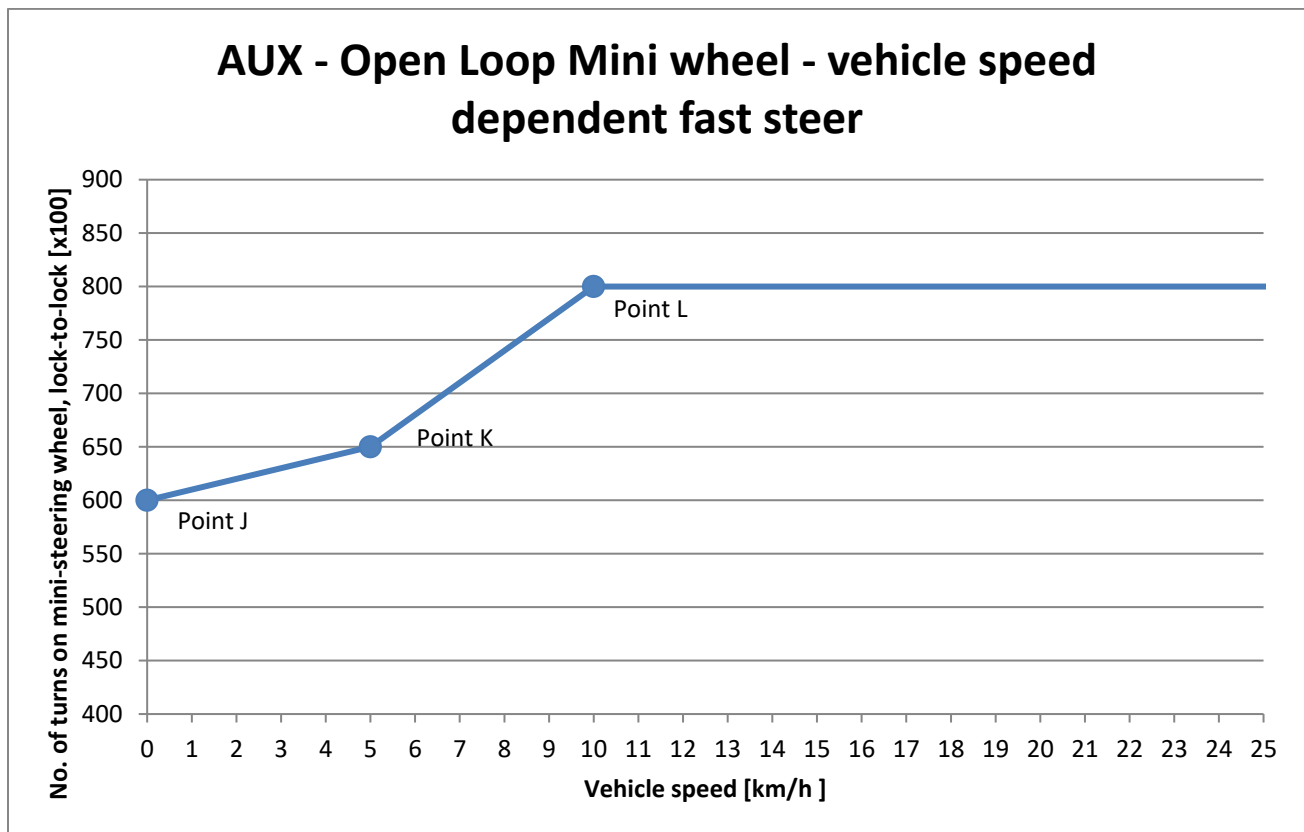

Figure 50

**Warning**

Danfoss strongly recommends that the Steering programs are set up to ensure safe operation at any vehicle speed. this implies that:

- 1. For every vehicle speed dependent steering program the configurable points shall result in a graph with positive slope.**
- 2. If a steering program is configured not to be vehicle speed dependent, it must be ensured that the configuration allows safe driving at all possible vehicle speeds.**
- 3. Unused steering programs shall be programmed with default values.**

Failure to comply with the above rules may render this function inoperable or lead to undesirable steering behavior!

11.4.1 Compensate steering sensitivity according to wheel angle range

PVED-CLS offers a feature to keep the steering sensitivity fixed if the physical max wheel angle range is changed due to adding/changing tires.

The native steering program sensitivities for the steering programs are defined for the native physical wheel angle range at programming time. The native wheel angle range is set by the parameter, '*Native wheel angle range for AUX steering programs*', P3742. The parameter shall not be modified unless new steering programs are created. This will ensure that the same aggressiveness in the steering system is maintained, even if the max angles change.

When the physical max wheel angle endpoints are changed by manual or WAS auto-calibration by one of the below conditions

- If WAS interface type in P3244 is selected as CAN and Automatic adjusted maximum steer angle to left side and right side, parameters P3193 and P3195 respectively, are changed OR
- If WAS interface type in P3244 is selected as Analogue WAS and Automatic adjusted maximum steer angle to left side and right side, parameters P3223 and P3225 respectively, are changed

Important

The Programmed lock to lock will not match the definition in EEPROM unless the actual wheel angle range matches 'Native wheel angle range for AUX steering programs'.

Important

If steering sensitivity compensation is not required, the feature can be disabled by setting the parameter 'Native wheel angle range for AUX steering programs, P3742 to 0 deg or to a value equal to or larger than 179deg. Furthermore, if parameter 'WAS Interface' P3244, is configured to no wheel angle sensor present then this feature will be disabled.



Name	Address	Data type	Unit	Description of parameter	User	Range		Danfoss default value	Safety critical parameters 'S'
						Min.	Max.		
AUX mini-steering 1 - No of turns @ Point J	P3650	U16	-	Program1 - Number of steering wheel turns lock to lock at the vehicle speed of 0 km/h Resolution = 0.01; Iturn = 100	OEM	10	800	800	
AUX mini-steering 1 - No of turns @ Point K	P3652	U16	-	Program1 - Number of steering wheel turns lock to lock at the vehicle speed of "AUX program 1 - Vehicle speed @ Point K" Resolution = 0.01; Iturn = 100	OEM	10	800	800	
AUX mini-steering 1 - No of turns @ Point L	P3654	U16	-	Program1 - Number of steering wheel turns lock to lock at the vehicle speed of "AUX program 1 - Vehicle speed @ Point L" Resolution = 0.01; Iturn = 100	OEM	10	800	800	
AUX mini-steering 1 - Vehicle speed @ Point K	P3656	U8	km/h	Program1 - Vehicle speed at which lock to lock steering wheel turns = "AUX program 1 - No of turns @ Point K"	OEM	1	100	5	
AUX mini-steering 1 - Vehicle speed @ Point L	P3657	U8	km/h	Program1: Vehicle speed at which lock to lock steering wheel turns = "AUX program 1 - No of turns @ Point L"	OEM	1	100	10	
AUX mini-steering 2 - No of turns @ Point J	P3658	U16	-	Program2 - Number of steering wheel turns lock to lock at the vehicle speed of 0 km/h Resolution = 0.01; Iturn = 100	OEM	10	800	800	
AUX mini-steering 2 - No of turns @ Point K	P3660	U16	-	Program2 - Number of steering wheel turns lock to lock at the vehicle speed of "AUX program 2 - Vehicle speed @ Point K" Resolution = 0.01; Iturn = 100	OEM	10	800	800	
AUX mini-steering 2 - No of turns @ Point L	P3662	U16	-	Program2 - Number of steering wheel turns lock to lock at the vehicle speed of "AUX program 2 - Vehicle speed @ Point L" Resolution = 0.01; Iturn = 100	OEM	10	800	800	
AUX mini-steering 2 - Vehicle speed @ Point K	P3664	U8	km/h	Program2 - Vehicle speed at which lock to lock steering wheel turns = "AUX program 2 - No of turns @ Point K"	OEM	1	100	5	
AUX mini-steering 2 - Vehicle speed @ Point L	P3665	U8	km/h	Program2: Vehicle speed at which lock to lock steering wheel turns = "AUX program 2 - No of turns @ Point L"	OEM	1	100	10	
AUX mini-steering 3 - No of turns @ Point J	P3666	U16	-	Program3 - Number of steering wheel turns lock to lock at the vehicle speed of 0 km/h Resolution = 0.01; Iturn = 100	OEM	10	800	800	
AUX mini-steering 3 - No of turns @ Point K	P3668	U16	-	Program3 - Number of steering wheel turns lock to lock at the vehicle speed of "AUX program 3 - Vehicle speed @ Point K" Resolution = 0.01; Iturn = 100	OEM	10	800	800	
AUX mini-steering 3 - No of turns @ Point L	P3670	U16	-	Program3 - Number of steering wheel turns lock to lock at the vehicle speed of "AUX program 3 - Vehicle speed @ Point L" Resolution = 0.01; Iturn = 100	OEM	10	800	800	
AUX mini-steering 3 - Vehicle speed @ Point K	P3672	U8	km/h	Program3 - Vehicle speed at which lock to lock steering wheel turns = "AUX program 3 - No of turns @ Point K"	OEM	1	100	5	
AUX mini-steering 3 - Vehicle speed @ Point L	P3673	U8	km/h	Program3: Vehicle speed at which lock to lock steering wheel turns = "AUX program 3 - No of turns @ Point L"	OEM	1	100	10	
AUX mini-steering 4 - No of turns @ Point J	P3674	U16	-	Program4 - Number of steering wheel turns lock to lock at the vehicle speed of 0 km/h Resolution = 0.01; Iturn = 100	OEM	10	800	800	
AUX mini-steering 4 - No of turns @ Point K	P3676	U16	-	Program4 - Number of steering wheel turns lock to lock at the vehicle speed of "AUX program 4 - Vehicle speed @ Point K" Resolution = 0.01; Iturn = 100	OEM	10	800	800	
AUX mini-steering 4 - No of turns @ Point L	P3678	U16	-	Program4 - Number of steering wheel turns lock to lock at the vehicle speed of "AUX program 4 - Vehicle speed @ Point L" Resolution = 0.01; Iturn = 100	OEM	10	800	800	
AUX mini-steering 4 - Vehicle speed @ Point K	P3680	U8	km/h	Program4 - Vehicle speed at which lock to lock steering wheel turns = "AUX program 4 - No of turns @ Point K"	OEM	1	100	5	
AUX mini-steering 4 - Vehicle speed @ Point L	P3681	U8	km/h	Program4: Vehicle speed at which lock to lock steering wheel turns = "AUX program 4 - No of turns @ Point L"	OEM	1	100	10	
AUX mini-steering 5 - No of turns @ Point J	P3682	U16	-	Program5 - Number of steering wheel turns lock to lock at the vehicle speed of 0 km/h Resolution = 0.01; Iturn = 100	OEM	10	800	800	
AUX mini-steering 5 - No of turns @ Point K	P3684	U16	-	Program5 - Number of steering wheel turns lock to lock at the vehicle speed of "AUX program 5 - Vehicle speed @ Point K" Resolution = 0.01; Iturn = 100	OEM	10	800	800	
AUX mini-steering 5 - No of turns @ Point L	P3686	U16	-	Program5 - Number of steering wheel turns lock to lock at the vehicle speed of "AUX program 5 - Vehicle speed @ Point L" Resolution = 0.01; Iturn = 100	OEM	10	800	800	
AUX mini-steering 5 - Vehicle speed @ Point K	P3688	U8	km/h	Program5 - Vehicle speed at which lock to lock steering wheel turns = "AUX program 5 - No of turns @ Point K"	OEM	1	100	5	
AUX mini-steering 5 - Vehicle speed @ Point L	P3689	U8	km/h	Program5: Vehicle speed at which lock to lock steering wheel turns = "AUX program 5 - No of turns @ Point L"	OEM	1	100	10	
Native wheel angle range for AUX steering programs	P3742	U8	deg	AUX Lock to lock wheel angle range Used internally to maintain the steering sensitivity/aggressiveness when physical max wheel angle endpoints are changed by changing/adding tires	OEM	0	255	255	S

Table 43



11.5 OPEN LOOP MINI-WHEEL ANTI-DRIFT (EFU)

The anti-drift function is implemented for eliminating internal leakage errors and for having the steering wheel in the same position when driving straight ahead. The functions control algorithm will determine the correct output flow (ccm per revolution) by adding an anti-drift correction portion to the calculated ideal ccm per revolution-output.

The anti-drift correction portion is calculated by looking at the difference, in degrees, measured at the steering wheel and the actual position of the wheels. The percentage of the full flow, which PVED-CLS's anti-drift algorithm will add is defined by the following four points, Point A to Point D, where Point B and Point C are configurable.

- Point A (0, 0)
- Point B (P3706, P3705)
- Point C (160, P3705)
- Point D (0, 0)

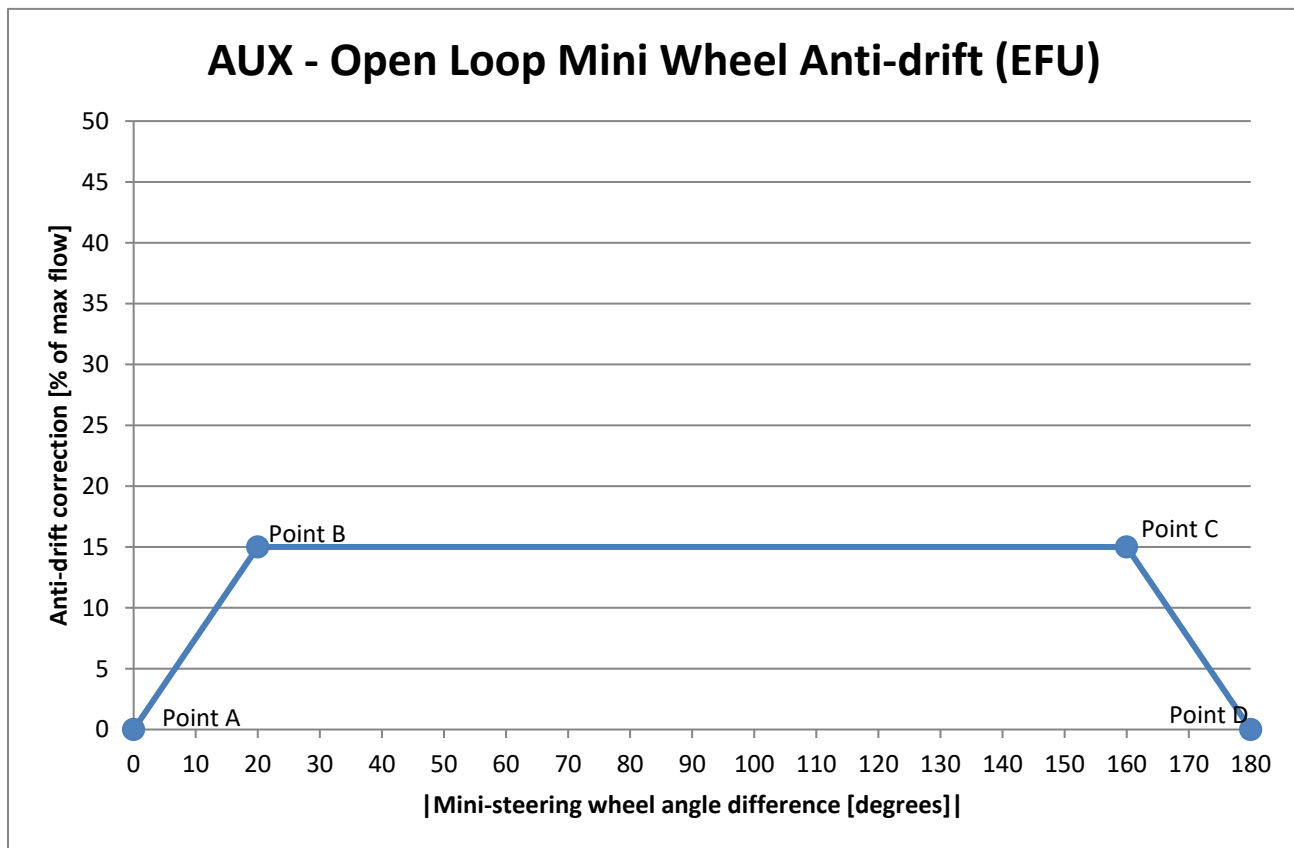

Figure 51

The range is from 1° to 160° for P3706, in steps of 1°. For P3705 the range goes from 0% to 100% in steps of 1%.

The values recommended by Danfoss are P3706 set to 20 and P3705 set to 15 i.e. anti-drift will be enabled all the time and 15% of the full flow will be added or deducted depending on direction, to the calculated ideal ccm per revolution-output, when the difference between the measured steering wheel position and the actual position of the wheels is 20° - 160° (due to Point B and Point C's coordinates). When steering wheel angle difference is > 160° linear interpolation between Point C and the fixed point D, will determine the anti-drift correction portion.

Furthermore, anti-drift function will also improve consistency in lock-to-lock on steering wheel.



Important

If anti-drift is not needed, the function can be disabled by setting P3705 to 0.

Name	Address	Data type	Unit	Description of parameter	User	Range		Danfoss default value	Safety critical parameters 'S'
						Min.	Max.		
AUX anti-drift - Max flow correction in percentages of full flow	P3705	U8	%	Max flow correction which can be requested by the EFU algorithm. If anti-drift is not needed, the function can be disabled by setting P3705 to 0	OEM	0	100	15	
AUX anti-drift - Max steering wheel drift correction	P3706	U16	Deg	The difference between the observed and ideal AUX steering angle at which and above which the max. EFU correction ("AUX Anti-drift - Max flow correction") shall be applied.	OEM	1	160	20	

Table 44

11.6 OPEN LOOP ANTI-JERK

Jerk is a common unpleasant feeling/phenomenon, which can be experienced on large, articulated vehicles. To minimize these jerks, the PVED-CLS has a built-in anti-jerk algorithm, which can be enabled and parameterized. The anti-jerk function applies to all AUX Open Loop steering devices.

Briefly, the Anti-jerk algorithm has two sets of parameters to choose from, one set for when moving away from neutral position and one set for moving towards neutral position.

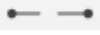
In the Figure 3 below, point S1 shows the current spool position and S2 shows the calculated flow command to PVED-CLS. The point Sa1, Sa2 and Sa3 shows adjusted flow set-points after applying anti-jerk algorithm. When the spool is at point S1 and when there is jerk in the system, the flow set-point S2 is calculated and is expected to reach S2 in one cycle which is shown by dotted line () curve.

The anti-jerk algorithm calculates the 'adjusted flow set-points' Sa1, Sa2 and Sa3 based on relative or absolute set-point changes in one cycle i.e. in 10 ms which is shown by line () in Figure and more smoother ramps will be applied to minimize the jerks in the system.

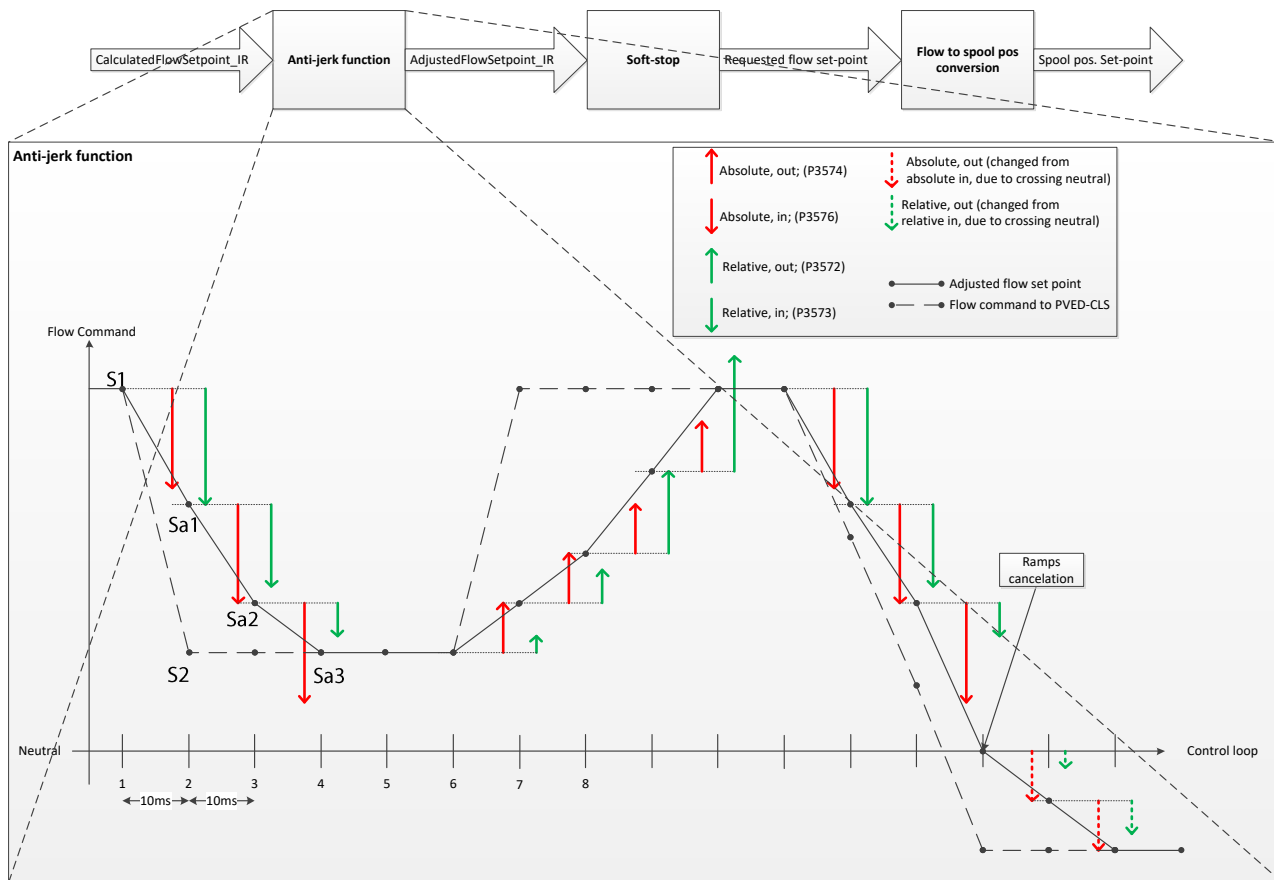

Figure 52

11.6.1 Calculation of flow set-point using anti-jerk functionality

The anti-jerk algorithm uses relative set-point parameters P3699 and P3700 in [%] and absolute set-point parameters P3701 and P3703 in [IR] and detects the relative or absolute set-point changes in one loop/cycle (10ms). The algorithm will choose the parameter (absolute or relative) which has the highest change of set-points for each loop (i.e. 10ms) and a new ‘modified flow set-point’ is calculated. Finally, the low pass filter is applied on the ‘modified flow set-point’ to calculate the ‘filtered flow set-point’.

The low pass filter in the function is configurable by P3718 (default cut-off frequency is 10Hz, i.e. P3718 set to 100).

If the EH-spool is commanded to go from left- to right-side or opposite, when crossing neutral, the ramps will be canceled and the parameter set will change from “moving towards neutral position” to “moving away from neutral position”.

For the relative set-point parameters (P3699 and P3700), the value will change depending on the actual spool position. For the absolute set-point change parameters (P3701 and P3703), the value will always be a fixed set-point value, parameters shall be configured accordingly.

Important

An anti-jerk function is normally only used on articulated vehicles, where jerk is very common.



Jerk is a sideways hard movement around the articulated point. This Anti-Jerk functionality will minimize the unpleasant sideways movement around the articulated point.

As an “on-the-top”-feature, further dampen of AUX speed fluctuations can be done. So if the general AUX Anti-jerk setup (P3699 to P3703) does not give a sufficient dampening/satisfying result, the anti-jerk on-the-top function can be enabled.

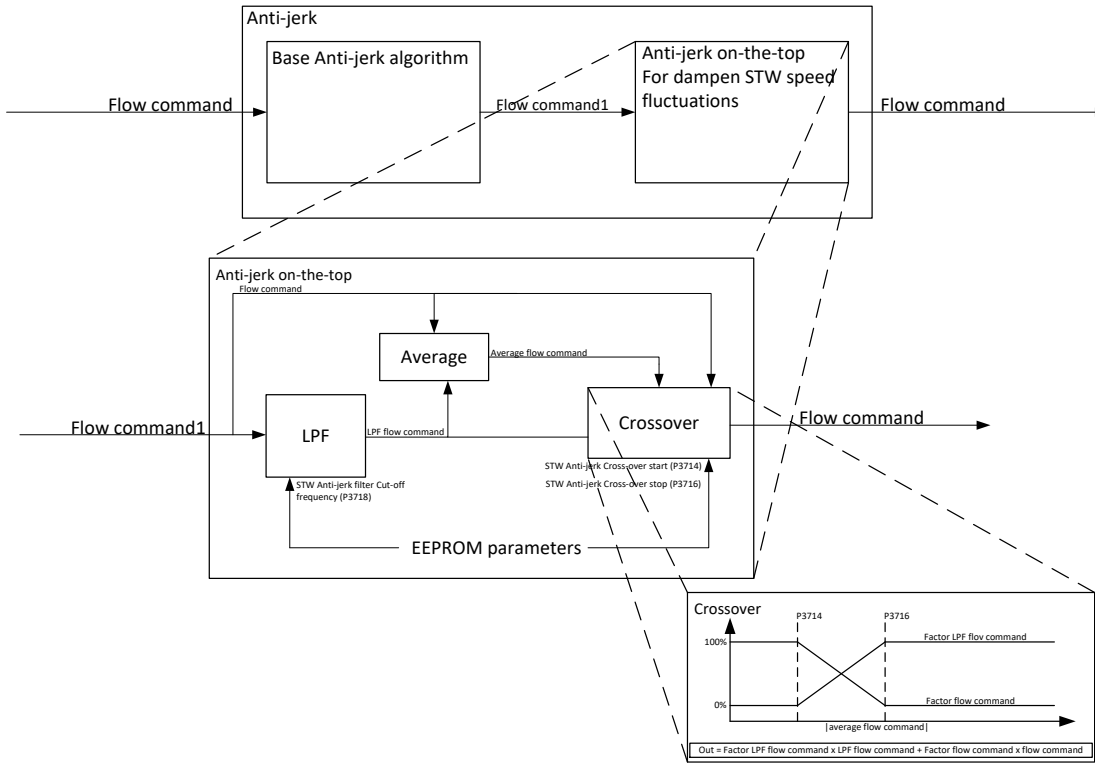

Figure 53

Referring to the Figure 5 below, the ‘crossover/mixing factor’ in percentage is calculated and is applied on ‘Filtered flow set-point’ (see 11.6.1) to calculate the final ‘flow set-point’ of Anti-jerk algorithm.

Parameters P3714 and P3716 are used to calculate the percentage crossover to be applied on the ‘filtered flow set-point’ (see 11.6.1) to calculate the final ‘flow set-point’ with anti-jerk functionality.

The ‘Crossover/mixing factor’ is defined by the piece-wise linear characteristics based on following points in Figure 54. The absolute value of average flow set-point is calculated from ‘Modified Flow Set-point’ (see 11.6.1) and ‘Filtered Flow Set-point’ (see 11.6.1) in IR.

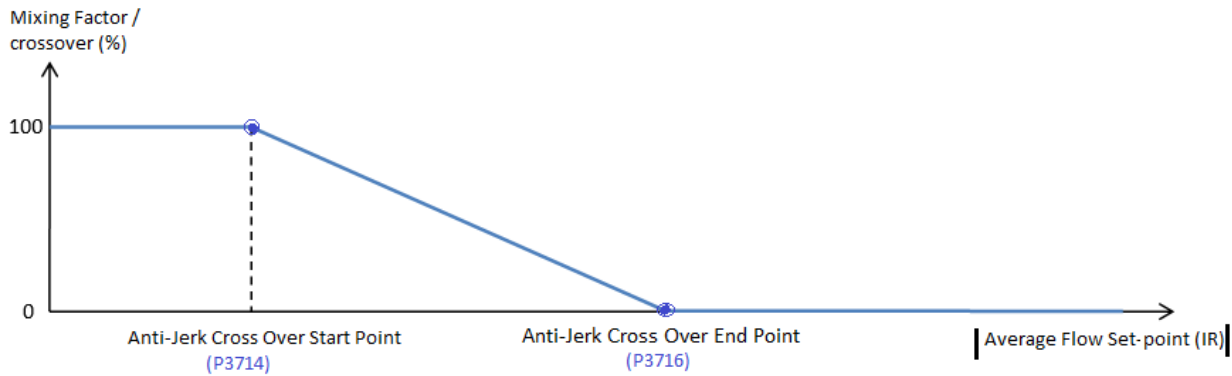

Figure 54

If P3714 is set to 1000 IR, the mixing factor 100 % will be considered for calculation of adjusted flow set-point.

As per default, P3714 and P3716 are both set to 10. Having these parameters set to the same value cancel out any crossover ramping. To enable the function, set P3714 and P3716 to a value between 0 and 1000 to indicate the crossover start (P3714) and crossover stop (P3716).

Name	Address	Data type	Unit	Description of parameter	User	Range		Danfoss default value	Safety critical parameters 'S'
						Min.	Max.		
AUX anti-jerk function	P3698	U8	-	Defines the type of the anti-jerk functionality to use 0 for Anti Jerk type NONE and 1 for Anti Jerk type 1	OEM	0	1	0	
AUX relative set-point change, in towards spool neutral position	P3699	U8	%	Relative set-point change allowed to apply when ramping the spool position set-point out, i.e. further out from the spool neutral position [%]	OEM	0	100	5	
AUX relative set-point change, out from spool neutral position	P3700	U8	%	Relative set-point change allowed to apply when ramping the spool position set-point in, i.e. towards the spool neutral position [%]	OEM	0	100	5	
AUX absolute set-point change, in towards spool neutral position	P3701	U16	IR	Set-point change allowed to apply when ramping the spool position set-point out, i.e. further out from the spool neutral position	OEM	1	1000	10	
AUX absolute set-point change, out from spool neutral position	P3703	U16	IR	Set-point change allowed to apply when ramping the spool position set-point in, i.e. towards the spool neutral position	OEM	1	1000	15	
AUX anti-jerk cross-over start point	P3714	U16	IR	AUX Anti-jerk Cross-over start	OEM	1	1000	10	
AUX anti-jerk cross-over stop point	P3716	U16	IR	AUX Anti-jerk Cross-over stop	OEM	1	1000	10	
AUX anti-jerk low pass filter cut-off frequency	P3718	U8	dHz	AUX Anti-jerk low pass filter cut-off frequency Resolution: 1 dHz = 0.1 Hz	OEM	5	200	100	

Table 45



11.7 OPEN LOOP SOFT STOP

The soft-stop function applies to all Open Loop configurations and limits the allowed maximum flow delivered to the steering cylinders in proportion to the relative wheel angle and is mirrored to both sides (left- and right-end stop). The function's control algorithm will implement a linear interpolation between two points, Point A and Point B.

- Point A (1000-P3710, 1000)
- Point B (1000-P3712, P3708)

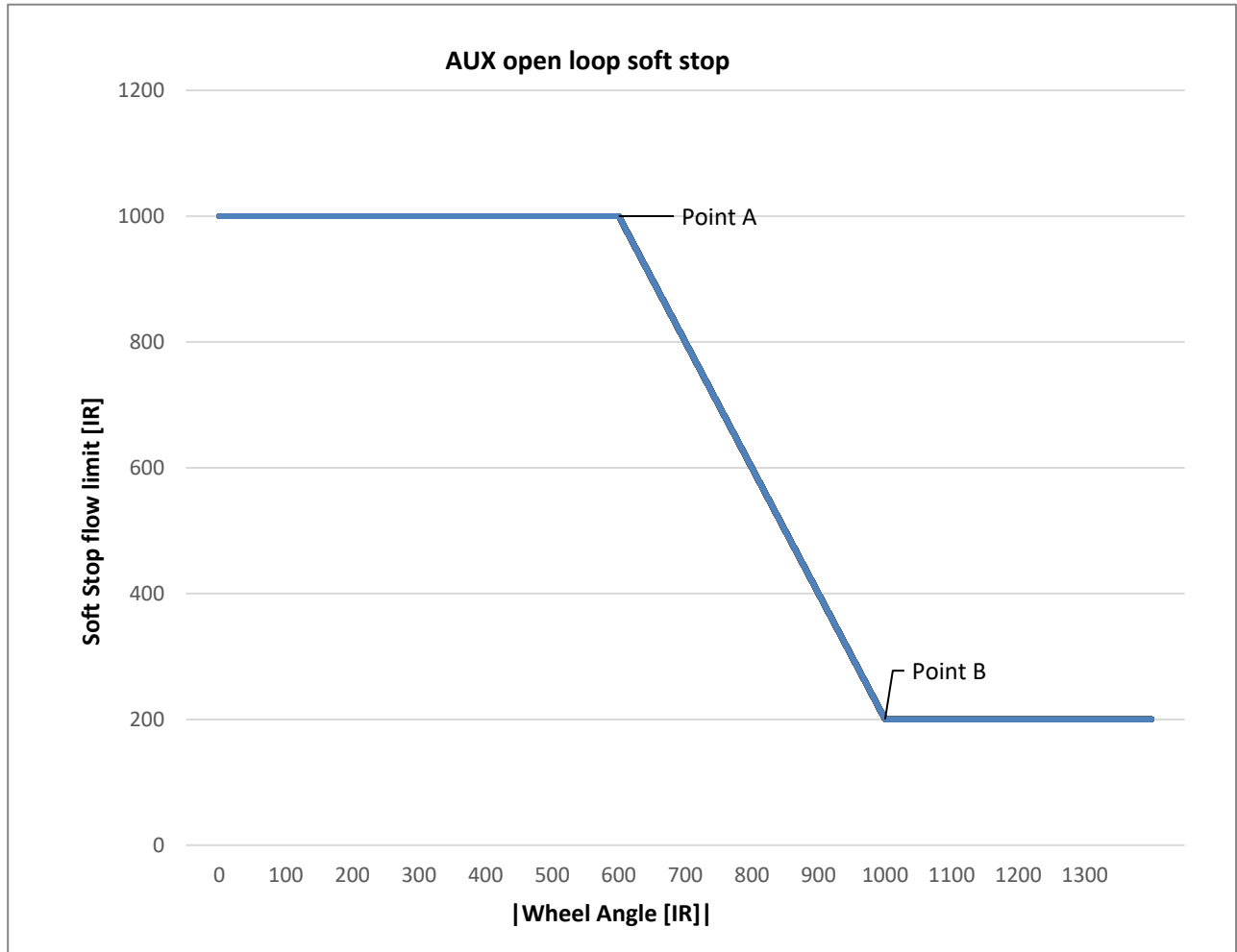

Figure 55

The range is from 100 to 1000 [IR] for P3708 (i.e. relative soft-stop flow limit).

The range is from 0 to 1000 [IR] for P3710 and P3712 (i.e. relative wheel angle).

The Danfoss recommended values are P3708 set to 200, and P3710 and P3712 set to 0. Soft stop functionality is disabled with default values.

Important

For wheel angles lower than the one specified at Point A, maximum flow is available.



Important

If soft-stop function is not required, it can be eliminated by setting P3708 to 1000.

Name	Address	Data type	Unit	Description of parameter	User	Range		Danfoss default value	Safety critical parameters 'S'
						Min.	Max.		
AUX soft-stop max flow @ cylinder end-stop	P3708	U16	IR	Oil flow to deliver at the max possible wheel angle	OEM	100	1000	200	
AUX soft-stop wheel angle region start	P3710	U16	IR	Defines the wheel angle region start, from the max possible wheel angle towards 0, in which the soft stop has to be applied	OEM	0	1000	0	
AUX soft-stop wheel angle region stop	P3712	U16	IR	Defines the wheel angle region end, from the max possible wheel angle towards 0, in which the soft stop has to be applied	OEM	0	1000	0	

Table 46

11.8 OPEN LOOP JOYSTICK – TRANSFER FUNCTION

While using open loop joystick with PVED-CLS it is possible to define a transfer function, which scales the open loop joystick position to a requested flow.

The transfer function configuration can be done by configuring the below parameters

- The parameter P3734, i.e. AUX joystick - Maximum deflection region offset, defines the dead-bands at each extremity of the transfer function.
- Parameter P3736, AUX joystick - Dead-band region, which defines the dead-band around neutral position.
- Parameter P3738 and P3740, i.e. Interpolation point X and Interpolation point Y respectively, to define the slope from the neutral dead-band to the point **P**(P3738,P3740) and from point **P** to the extremity dead-band on positive side.

Similarly from the – (neutral dead-band) to the point **Q** (-P3738, -P3740) and from point **Q** to the extremity dead-band on negative side.

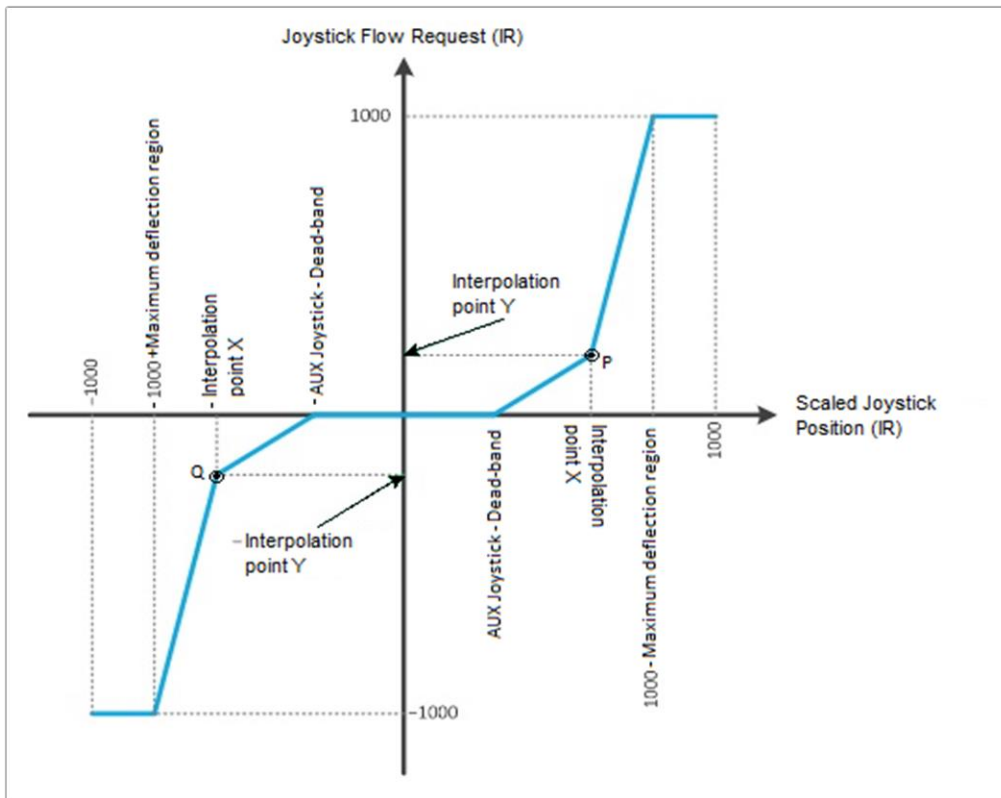

Figure 56

The open loop transfer function applies for all open loop joysticks and allows joystick flow request scaled to the internal resolution, using piecewise linear conversion, based on slope values defined by parameters P3734 to P3740, of the scaled joystick position limited by following rules-

- P3734 i.e. ‘AUX joystick-Maximum deflection region offset’ is less than or equal to (1000 IR – P3738 i.e. ‘AUX joystick-Interpolation point X for open loop joystick transfer function’).
- P3740 i.e. ‘AUX joystick - Interpolation point Y for open loop joystick transfer function’ shall be greater than 0 and less than or equal to 1000 IR.
- P3736 i.e. ‘AUX joystick - Dead-band region’ shall be less than or equal to P3738.

PVED-CLS will enter safe state if these rules are not followed.

Name	Address	Data type	Unit	Description of parameter	User	Range		Danfoss default value	Safety critical parameters ‘S’
						Min.	Max.		
AUX joystick - Maximum deflection region offset	P3734	U16	IR	AUX joystick - Maximum joystick deflection region offset from scaled MAX position 1000 IR	OEM	0	1000	0	
AUX joystick - Dead-band region	P3736	U16	IR	AUX joystick - Neutral dead-band region for open loop transfer function	OEM	0	1000	0	
AUX joystick - Interpolation point X for open loop joystick transfer function	P3738	U16	IR	AUX Joystick - Interpolation point X for open loop Joystick transfer function	OEM	0	1000	1000	
AUX joystick - Interpolation point Y for open loop joystick transfer function	P3740	U16	IR	AUX Joystick - Interpolation point Y for open loop Joystick transfer function	OEM	0	1000	1000	

Table 47



11.9 OPEN LOOP JOYSTICK – VEHICLE SPEED DEPENDENT FLOW SCALING

As a risk mitigation method, when using the open loop joystick functionality in AUX steering mode, the PVED-CLS's AUX control algorithm can also limit and scale the maximum allowed output flow in proportion to the vehicle speed (i.e. the faster the vehicle goes the lower the maximum allowed flow will be).

The flow scaling algorithm calculates the maximum flow allowed based on vehicle speed. The determined maximum flow is scaled to the full joystick input range so that always the full joystick stroke is utilized. This gives better controllability at high vehicle speeds as the joystick sensitivity is reduced. A calculation example of the flow scaling function is shown below:

If the flow limit at a given vehicle speed is calculated to 400 IR and the joystick position is 700 IR, the resulting flow command calculated by PVED-CLS will be $700 \text{ IR} * (400\text{IR}/1000\text{IR}) = 280\text{IR}$.

The flow scaling function is configured by following parameters: P3696 and P3697 set the vehicle speed (range from 0 to 100 km/h) and P3690, P3692 and P3694 set the maximum flow (range from 0 to 1000 IR).

These parameters represent the three points on the curve below (Point M, N and O). The Open Loop AUX Joystick algorithm will make linear interpolation in between each of the three points. It is allowed to move the three points in any direction, limited by the following rules:

- Point M is always specified at Vehicle speed limited flow = 0 km/h
- Point O "Max flow" is valid for Point O "Vehicle speed limited flow" and vehicle speeds above Point O "Vehicle speed limited flow"
- Point M "Max flow" \geq Point N "Max flow" \geq Point O "Max flow"
- Point O "Vehicle speed limited flow" $>$ Point N "Vehicle speed limited flow" $>$ Point M "Vehicle speed limited flow"

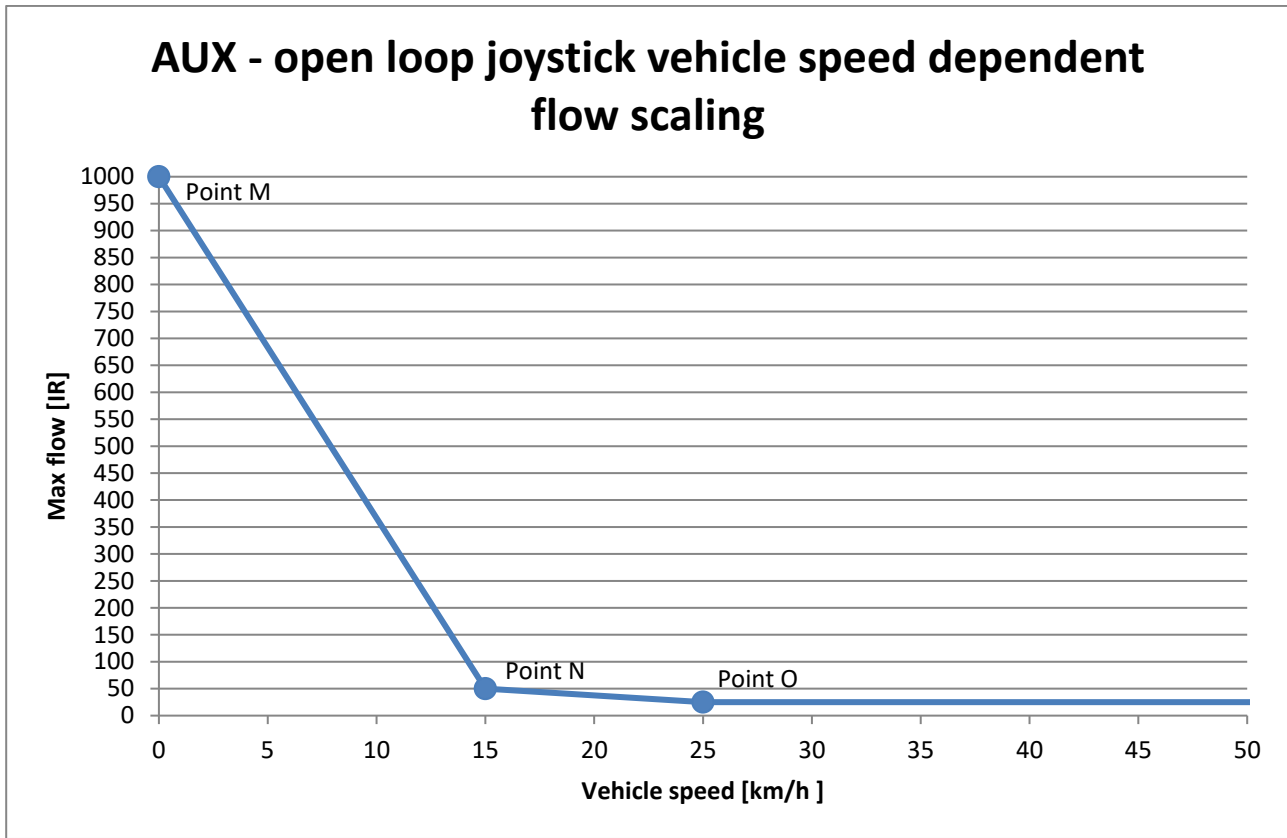

Figure 57

Warning



Failure to comply with the above rules may render this function inoperable or lead to undesirable steering behavior!

Name	Address	Data type	Unit	Description of parameter	User	Range		Danfoss default value	Safety critical parameters 'S'
						Min.	Max.		
AUX joystick - Flow limit for max joystick command @ Point M	P3690	U16	lR	Aux Joystick: flow limit for maximum joystick command at Vehicle speed of 0 km/h	OEM	0	1000	1000	
AUX joystick - Flow limit for max joystick command @ Point N	P3692	U16	lR	Aux Joystick - flow limit for maximum joystick command at the vehicle speed of "Aux Joystick - Vehicle speed @ Point N"	OEM	0	1000	50	
AUX joystick - Flow limit for max joystick command @ Point O	P3694	U16	lR	Aux Joystick - flow limit for maximum joystick command at the vehicle speed of "Aux Joystick - Vehicle speed @ Point O"	OEM	0	1000	25	
AUX joystick - Vehicle speed @ Point N	P3696	U8	km/h	Aux Joystick - Vehicle speed to limit the flow @ point N for maximum joystick command	OEM	0	100	15	
AUX joystick - Vehicle speed @ Point O	P3697	U8	km/h	Aux Joystick - Vehicle speed to limit the flow @ point O for maximum joystick command	OEM	0	100	25	

Table 48



11.10 CLOSED LOOP JOYSTICK – VEHICLE SPEED DEPENDENT WHEEL ANGLE LIMITATION

As a risk mitigation method, when using a Closed Loop Joystick function, the PVED-CLS’s Closed Loop Joystick control algorithm can limit the maximum allowed angle, that the wheels can be moved to, in proportion to the vehicle speed (i.e. the faster the vehicle goes, the narrower the maximum allowed angle, that the wheel can be moved to, will be).

The range is from 0 to 100 km/h for P3723 and P3724 and from 0 to 89 [°] for P3720, P3721 and P3722.

These parameters represent the three points on the curve below (Point A, B and C). The Closed Loop Joystick-algorithm will make linear interpolation in between each of the three points. It is allowed to move the three points in any direction, limited by the following rules:

- Point A is always specified at Vehicle speed limiting wheel angle = 0 km/h
- Point C “Max wheel angle” is valid for Point C “Vehicle speed limiting wheel angle” and vehicle speeds above Point C “Vehicle speed limiting wheel angle”
- Point A “Max wheel angle” \geq Point B “Max wheel angle” \geq Point C “Max wheel angle”
- Point C “Vehicle speed limiting wheel angle” $>$ Point B “Vehicle speed limiting wheel angle” $>$ Point A “Vehicle speed limiting wheel angle”

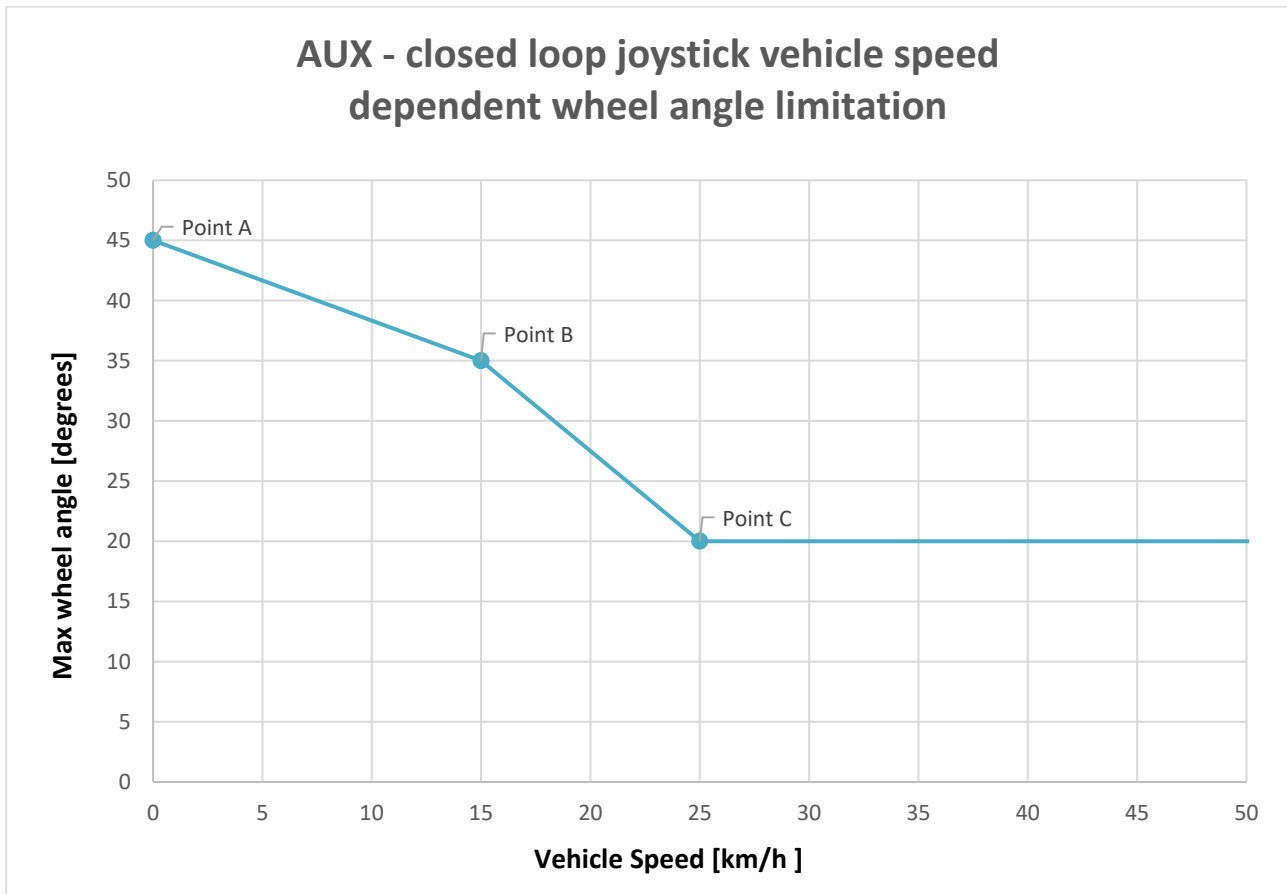

Figure 58

Warning



Failure to comply with the above rules may render this function inoperable or lead to undesirable steering behavior!

After a desired max wheel angle has been found by the PVED-CLS, in terms of the vehicle speed, the PVED-CLS will scale and interpolate to that max wheel angle, see example in Figure .

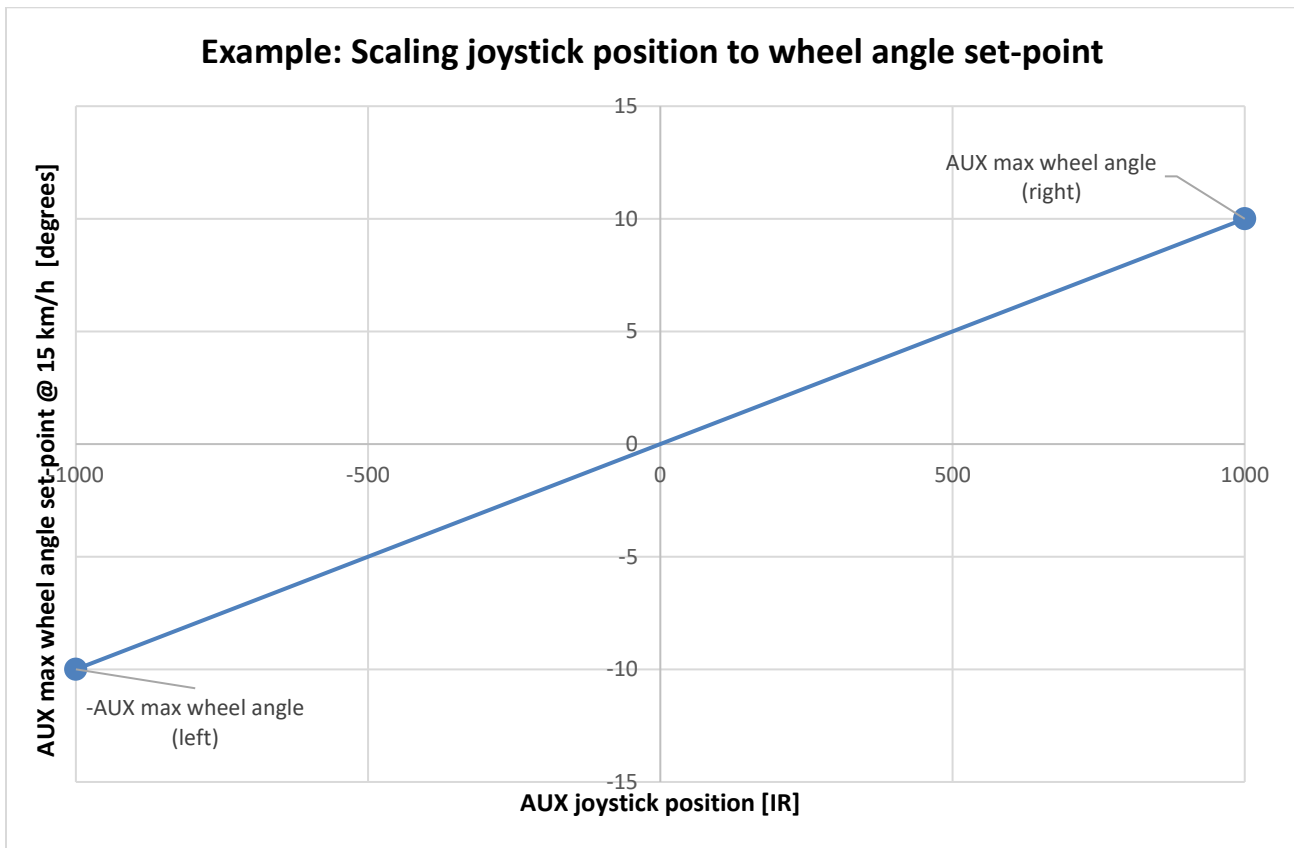

Figure 59

In Figure , an example is shown, using the default parameters for parameters P3720 to P3724 (see Figure and Table 49). Figure is considering a vehicle speed of 15 km/h, where the corresponding max wheel angle is 10°. The PVED-CLS will scale, using interpolation, from AUX max wheel angle (left) to 0,0 and from 0,0 to AUX max wheel angle (right).

The PVED-CLS will execute this scaling-calculation every 10ms.



Name	Address	Data type	Unit	Description of parameter	User	Range		Danfoss default value	Safety critical parameters 'S'
						Min.	Max.		
AUX joystick - Max wheel angle @ Point A	P3720	U8	Deg	AUX Joystick - Maximum allowed wheel angle at the vehicle speed of 0 km/h	OEM	0	89	15	S
AUX joystick - Max wheel angle @ Point B	P3721	U8	Deg	AUX Joystick - Maximum allowed wheel angle at the vehicle speed "AUX Joystick - Vehicle speed limiting wheel angle @ Point B"	OEM	0	89	10	S
AUX joystick - Max wheel angle @ Point C	P3722	U8	Deg	AUX Joystick - Maximum allowed wheel angle at the vehicle speed "AUX Joystick - Vehicle speed limiting wheel angle @ Point C"	OEM	0	89	5	S
AUX joystick - Vehicle speed limiting wheel angle @ Point B	P3723	U8	km/h	AUX Joystick - Vehicle speed at which the flow should be limited to "AUX Joystick - Max wheel angle @ Point B"	OEM	0	100	15	S
AUX joystick - Vehicle speed limiting wheel angle @ Point C	P3724	U8	km/h	AUX Joystick - Vehicle speed at which the flow should be limited to "AUX Joystick - Max wheel angle @ Point C"	OEM	0	100	25	S

Table 49

11.11 CLOSED LOOP JOYSTICK – VEHICLE SPEED DEPENDENT CLOSED LOOP CONTROL

As each application is different, Danfoss has implemented a speed dependent closed loop control gain, configurable for Closed Loop Joystick. When using a Closed Loop Joystick function, the PVED-CLS’s Closed Loop Joystick-control algorithm can vary the closed loop gain, dependent on the vehicle speed.

The range is from 0 to 100 km/h for P3728 to P3729 and from 0 to 200 [%] for P3725 to P3727.

These parameters represent the three points on the figure 60 (Point A, B and C). The Auto-guidance-algorithm will make linear interpolation in between each of the three points. It is allowed to move the three points in any direction, limited by the following rules:

- Point A is always specified at Vehicle speed = 0 km/h
- The Vehicle speed has to increase for each point, hence “Vehicle speed” for Point A < “Vehicle speed” for Point B and “Vehicle speed” for Point B < “Vehicle speed” for Point C.
- Point C “Closed loop gain” is valid for Point C “Vehicle speed” and vehicle speeds above Point C “Vehicle speed”

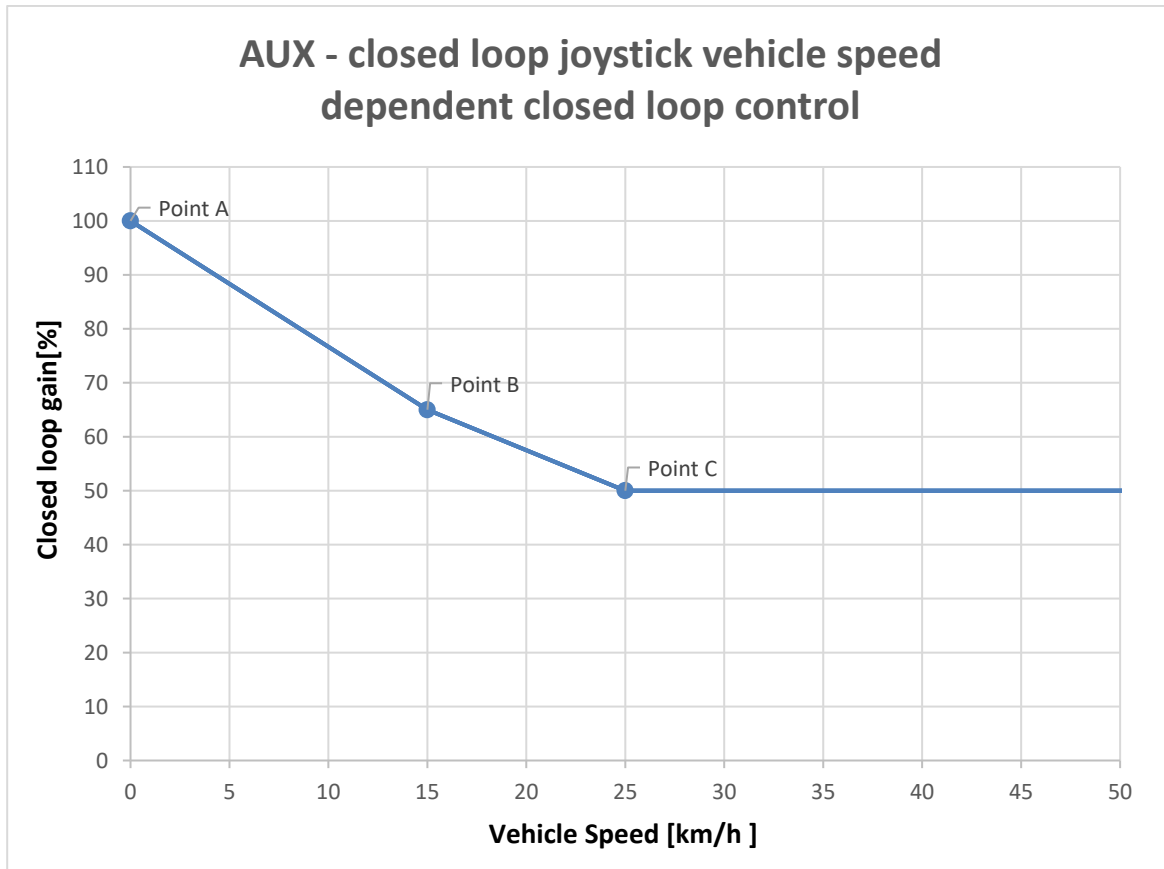

Figure 60

Warning



Setting the closed loop gain at a too high level could give unwanted aggressive steering behavior in AUX closed loop joystick mode, especially in combination with a low vehicle speed this could lead to unwanted aggressive steering behavior.

Name	Address	Data type	Unit	Description of parameter	User	Range		Danfoss default value	Safety critical parameters 'S'
						Min.	Max.		
AUX joystick - CL gain @ Point A	P3725	U8	%	AUX Joystick - Closed loop proportional gain at 0 km/h	OEM	0	200	50	S
AUX joystick - CL gain @ Point B	P3726	U8	%	AUX Joystick - Closed loop proportional gain at "AUX Joystick - Vehicle speed @ Point B"	OEM	0	200	50	S
AUX joystick - CL gain @ Point C	P3727	U8	%	AUX Joystick - Closed loop proportional gain at "AUX Joystick - Vehicle speed @ Point C"	OEM	0	200	50	S
AUX joystick - Vehicle speed @ Point B	P3728	U8	km/h	AUX Joystick - Vehicle speed at "AUX - CL gain @ Point B"	OEM	0	100	15	S
AUX joystick - Vehicle speed @ Point C	P3729	U8	km/h	AUX Joystick - Vehicle speed at "AUX - CL gain @ Point C"	OEM	0	100	25	S

Table 50



11.12 AUX TYPE - ELOBAU JOYSTICK

PVED-CLS is compatible to be configured with ELOBAU joystick series J4F with 351JCM, an auxiliary joystick. Two J4F joysticks can be present on vehicle, in the same CAN network, as joystick 1 and joystick 2 for right and left hand operations respectively.

PVED-CLS will accept and process below steering related signals received from ELOBAU joystick

- **Basic Joystick Message (BJM):**
BJM and inverted BJM shall be received as a message pair where, main controller uses BJM message and Safety controller uses inverted BJM.
- **Extended Joystick Message (EJM):**
EJM and inverted EJM shall be received as a message pair where, main controller uses EJM message and Safety controller uses inverted EJM.

If there are two J4F joysticks present on vehicle, in one CAN network, then the right joystick will use BJM1, EJM1 and left joystick will use BJM2 and EJM2 messages.

PVED-CLS processes the received percentage value of Joystick position signal (X-axis position), intended for steering. Percentage values received from joystick for x-axis position are from 0.0 % to 100.0 %, i.e. from 0 to 1000, with resolution of 0.1%, and those will be used for steering purpose. If the received x-axis position is greater than 100.0%, i.e. if greater than 1000, PVED-CLS will enter safe state.

Below is the graphical overview of how ELOBAU joystick signal is processed and then used for steering, using open loop joystick control.

For safety controller:

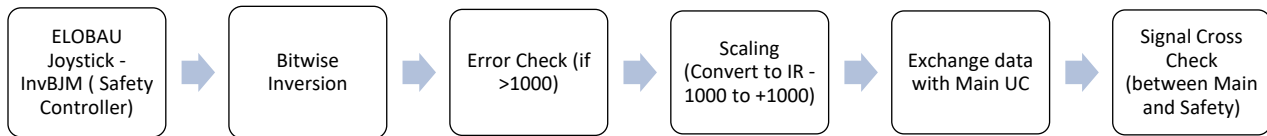

Figure 61

For main controller:

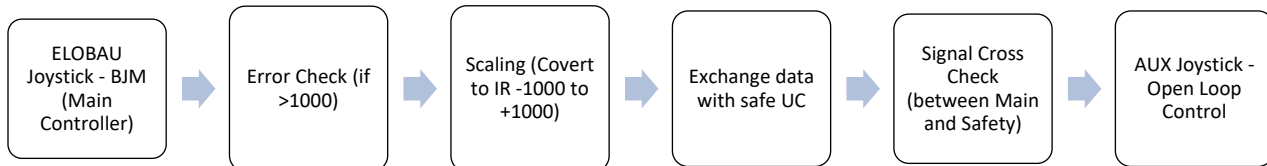

Figure 62

Once PVED-CLS receives the BJM and invBJM, byte 1 and 2 of invBJM will be bitwise inverted in safety controller.



11.12.1 Validation of Elobau Joystick Position Status

Elobau joystick message i.e. BJM/EJM contains 'x-axis position status', PVED-CLS performs validation on the x-axis position status as shown in below table.

X-axis position status bits in Byte1 of BJM						X-axis Position Status
Right position status		Left position status		Neutral position status		
bit6	bit5	bit4	bit3	bit2	bit1	
0	1	0	0	0	0	Right - Valid
0	0	0	1	0	0	Left - Valid
0	0	0	0	0	1	Neutral - Valid
All Remaining combinations						Invalid, Trigger Safe State

Table 51

PVED-CLS also checks if the Joystick position status and X-axis position are consistent with each other, if not PVED-CLS triggers safe state.

11.12.2 Validation and Scaling of Elobau Joystick Position

Error check on the received x-axis position signal is performed in both main and safety controller i.e. if received x-axis position is greater than 1000 then PVED-CLS will trigger safe state.

During Scaling, X-axis position received will be converted to PVED-CLS internal resolution i.e. from -1000 IR to +1000 IR and is performed by considering following conditions

- If received 'X-axis position status' is 'X-axis position Left' (01) then
Scaled joystick position = X-axis position * (-1), hence obtained value will be between -1000 IR to -1 IR
- If received 'X-axis position status' is 'X-axis position Right' (01) then
Scaled joystick position = X-axis position, hence obtained value will be between 1 IR to 1000 IR
- If received 'X-axis position status' is 'X-axis position Neutral' (01) then
Scaled joystick position = 0 IR

Scaled X-axis position in IR is calculated in both main and safety controller and then exchanged with each other for signal crosscheck. In case the difference between scaled values is greater than allowed tolerance specified by P3369 (*Channel cross-check monitoring - Max AUX joystick position divergence*) continuously for more than the time specified by P3368 (*Channel cross-check monitoring - max AUX joystick position divergence time*) then safe state will be triggered.

For information to set the above two parameters P3369 and P3368, please refer the ELOBAU document "*Operating/Safety Manual for J4F with 351JCM*".

11.12.3 Time guarding on Elobau Joystick Messages:

PVED-CLS also performs time guarding on BJM/EJM messages received from ELOBAU joystick. P3291 (*CAN message monitoring - AUX message monitoring - Max time difference between two messages*) specifies the delta time between two consecutive BJM/EJM messages. Safe state will be triggered if next message is not received within time specified by P3291.



For information to set the above two parameters P3291, please refer the ELOBAU document “Operating/Safety Manual for J4F with 351JCM”.

11.12.4 Elobau Joystick - Parameter Configuration

Name	Address	Data type	Unit	Description of parameter	User	Range		Danfoss default value	Safety critical parameters ‘S’
						Min.	Max.		
AUX present	P3239	U8	-	AUX device Present/Not Present Valid Values: 0 (NOT PRESENT); 255 (PRESENT)	OEM	0	255	0	
AUX type	P3240	U8	-	Aux device is mini steering wheel or Joystick Valid Values: 0 (Open Loop Joystick); 1 (Closed Loop Joystick); 2 (mini steering wheel); 3 (Analogue Joystick);20 (Elobau joystick)	OEM	0	20	2	
PGN for AUX Elobau joystick	P3329	U16	-	PGN for Aux Elobau Joystick- PGN' values for BJM1,BJM2,EJM1 and EJM2 are 64982,64984,64983 and 64985 respectively.	OEM	0	65535	64982	
AUX device (joystick) source address	P3300	U8	-	J1939 Source Address of the AUX device (joystick)	OEM	0	253	78	
AUX joystick in use - Flow command threshold	P3647	U8	IR	AUX Joystick flow command threshold to declare that joystick is in use	OEM	0	100	10	S

Table 52

Important

The PVED-CLS will only handle byte 1 and 2 of BJM and EJM messages received from ELOBAU joystick, all other bytes are treated as “don’t cares” by the PVED-CLS and no checks will be performed on these.

Important

Danfoss PVED-CLS is not handling DM1 message send by the ELOBAU Joystick as this is not relevant for steering applications.

12 Auto-guidance steering

When the PVED-CLS is in off-road steering mode (see Figure) the Auto-guidance steering can be chosen. Furthermore, the PVED-CLS can be configured in such a way, that two auto-guidance controllers (GPS and GPS2) can be interfaced.

Two safety functions for auto-guidance controllers (GPS and GPS2) can be configured, which can be enabled and run simultaneously. In addition, these functions are dependent on the vehicle's speed and can limit the maximum wheel angles and flow allowed in Auto-guidance steering.

12.1 BLOCK DIAGRAM

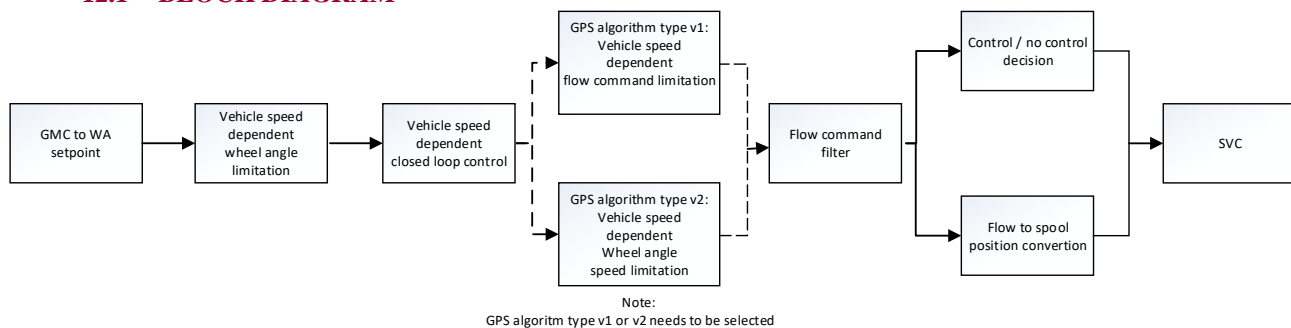

Figure 63

12.2 SELECTION OF GPS ALGORITHM TYPE

It is possible to select GPS algorithm type:

GPS v1: Vehicle speed dependent flow limitation

GPS v2: Vehicle speed dependent wheel angle speed limitation.

Selection is done from the service tool under GPS config in parameter P3496: GPS Algorithm type.

GPS v1:

If the max WA and cylinder size are unknown.

If a series of machines will not have variation in cylinder size and max WA (same lock stops position across fleet).

If the lock stops are changed after tuning and the WA is re-calibrated at it should, it will influence the system gain.

Unless the max angles are updated, the curvature to angle conversion will not be accurate. Further the gain in the system will change. Small changes will have limited influence in steering accuracy, but if WA is halved or doubled, the steering inaccuracy will increase



GPS v2:

If the max WA and cylinder size are known.

Suitable for larger series of machines, where different applications or tire dimensions will result in different lock stop settings.

When the wheel angle cal. can estimate the max WA and cylinder size at calibration time, the curvature command to wheel angle conversion will be accurate and system gain will also stay the same.

If machines where lock stops are changed also in field, the max WA and cylinder size must be known, to use this method. With this method there will not be adverse effects in guidance performance, due to changes in geometry.

In both modes the WA should be re-calibrated if lock stops are changed, for diagnostic purposes.

Further details see chapter 12.6 and 12.6

Important

Changing GPS algorithm type, may result in that gain parameters in section 12.5 Vehicle speed dependent closed loop control needs to be adjusted.

P3496: GPS Algorithm Type

GPS v2 ▾

Figure 64

Name	Address	Data type	Description of parameter	User	Range		Danfoss default value	Safety critical parameters 'S'
					Min.	Max.		
GPS – Algorithm type	P3496	U16	Vehicle speed dependent flow limitation value = 0 => GPS v1 Vehicle speed dependent wheel angle speed limitation = 1 => GPS v2	OEM	0	1	0	S

Table 53

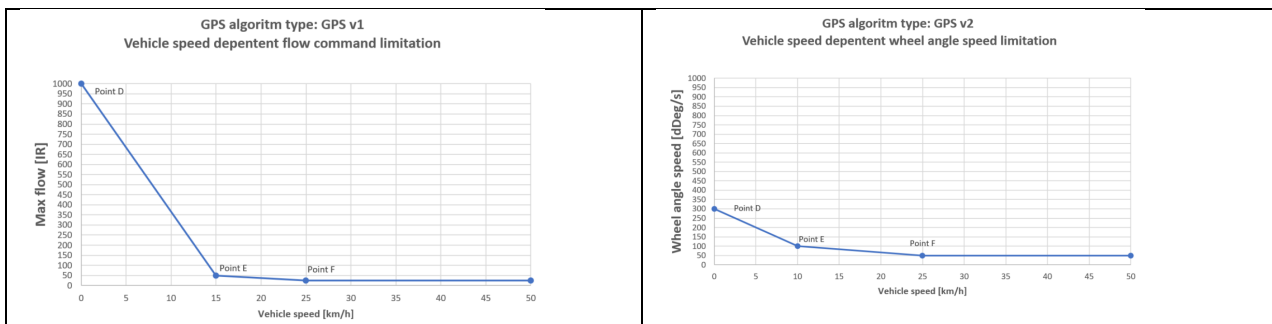

Figure 65

Warning



As parameter address is identical for GPS algorithm type v1 and v2, parameters values must accordingly be adjusted to meet application requirement, when the GPS algorithm type is changed

12.3 GPS CONFIG

As a risk mitigation method, disengaging the Auto-guidance-program and return to STW mode (hydraulic steering only) is possible by activating/turning the steering wheel. When driving off-road, an uneven surface etc. may disengage the Auto-guidance steering mode. In order to allow small movements of the steering wheel without disengaging the Auto-guidance steering, appropriate disengage threshold values should be written in P3583 and P3584.

The PVED-CLS detects that the steering wheel is used when both the threshold P3583 and P3584 are being exceeded. In order to switch to auto-guidance program from STW or AUX program, following conditions shall be satisfied

- To switch from STW program to auto-guidance program, the steering wheel shall not be in use i.e. the absolute steering wheel velocity shall be lower than or equal to STW in use – Velocity threshold (P3583).
- To switch from AUX program to auto-guidance program, if an AUX device is present in the system i.e. P3239 set to 255 AND
 - The AUX steering device is a ‘mini-steering wheel’ i.e. P3240 set to 2 AND absolute value of ‘AUX mini-steering wheel velocity’ is less than or equal to the ‘AUX mini-steering in use – Velocity threshold’ i.e. P3646.
OR
 - The AUX steering device is an ‘open loop joystick’ (P3240 set to 0 - *Open Loop Joystick* OR P3240 set to 3 - *Analogue Joystick* OR P3240 set to 20 - *Elobau joystick*) AND the absolute value of ‘Requested AUX joystick flow command’ is lower than ‘AUX joystick in use – Flow command threshold’ i.e. P3647.
OR
 - The AUX steering device is a ‘closed loop joystick’ i.e. P3240 set to 1 AND the absolute value of ‘AUX steering device related closed loop error’ is lower than ‘AUX joystick - Max. CL steady state error threshold’ i.e. P3730 for at least the time specified by P3731 (*AUX joystick - Min time for CL steady state error threshold*) AND closed loop joystick is inactive (see flags in the AUX messages in PVED-CLS communication protocol).

Important

The same “steering wheel in use”-algorithm is used for AUX-steering programs, hence the same rules are used to perform a transition to the AUX-program.

P3484 controls a Low-pass filter, which can be applied upon the calculated flow command. If P3484 is set to 0, the filter is disabled. This filter can be used to dampen machine steering commands for minimizing jerky vehicle movements and hereby avoid introducing oscillations in the auto-guidance feedback loop.

Important

Setting the filter value too low will slow down the auto-guidance steering performance. Danfoss recommends not to change the default value of P3484.



Name	Address	Data type	Unit	Description of parameter	User	Range		Danfoss default value	Safety critical parameters 'S'
						Min.	Max.		
GPS - Flow command filter frequency	P3484	U8	dHz	Auto-guidance flow command filter cut-off frequency	OEM	0	200	0	
STW in use - Velocity threshold	P3583	U8	dRpm	Steering wheel velocity threshold	OEM	1	100	5	S
STW in use - Angle threshold	P3584	U8	Deg	Steering wheel position change threshold, from last detected position at 0 RPM	OEM	0	45	10	S
AUX mini-steering in use - Velocity threshold	P3646	U8	dRpm	AUX mini-steering velocity threshold to declare that the steering is in use	OEM	0	100	15	S
AUX joystick in use - Flow command threshold	P3647	U8	IR	AUX Joystick flow command threshold to declare that joystick is in use	OEM	0	100	10	S
AUX joystick - Max CL steady state error threshold	P3730	U8	IR	AUX Joystick - Maximum closed loop steady state error allowed for changing steering device from AUX to auto-guidance	OEM	0	200	100	S
AUX joystick - Min time for CL steady state error threshold	P3731	U8	X10mSec	AUX Joystick - The minimum amount of time for where the CL steady state error threshold (i.e. value for P3730) should not be exceeded, for being able to change steering device from AUX to auto-guidance	OEM	0	255	50	S

Table 54

12.4 VEHICLE SPEED DEPENDENT WHEEL ANGLE LIMITATION

As a risk mitigation method, when using an auto-guidance function, the PVED-CLS's auto-guidance control algorithm can limit the maximum allowed angle, that the wheels can be moved to, in proportion to the vehicle speed (i.e. the faster the vehicle goes, the narrower the maximum allowed angle, that the wheel can be moved to, will be).

The range is from 0 to 100 km/h for P3463 and P3467 and from 0 to 89 [°] for P3461, P3465 and P3469.

Important

This function applies to both GPS and GPS2.

These parameters represent the three points on the curve below (Point G, H and I). The auto-guidance algorithm will make linear interpolation in between each of the three points. It is allowed to move the three points in any direction, limited by the following rules:

- Point G is always specified at Vehicle speed limiting wheel angle = 0 km/h
- Point I "Max wheel angle" is valid for Point I "Vehicle speed limiting wheel angle" and vehicle speeds above Point I "Vehicle speed limiting wheel angle"
- Point G "Max wheel angle" \geq Point H "Max wheel angle" \geq Point I "Max wheel angle"
- Point I "Vehicle speed limiting wheel angle" $>$ Point H "Vehicle speed limiting wheel angle" $>$ Point G "Vehicle speed limiting wheel angle"

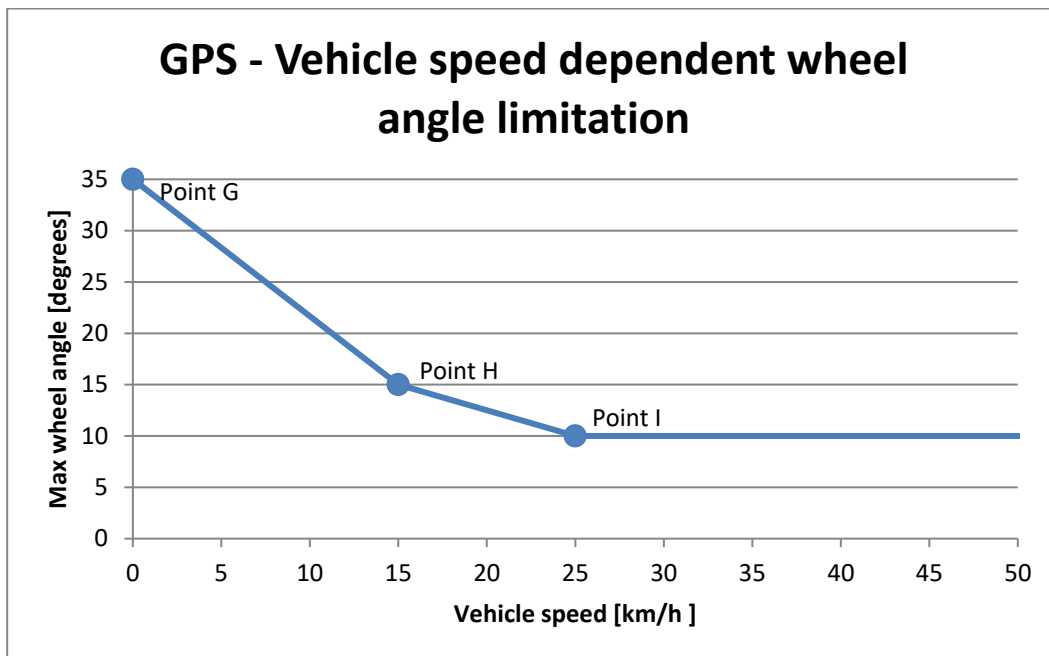

Figure 66

Warning



Failure to comply with the above rules may render this function inoperable or lead to undesirable steering behavior!



Name	Address	Data type	Unit	Description of parameter	User	Range		Danfoss default value	Safety critical parameters 'S'
						Min.	Max.		
GPS - Max wheel angle @ Point G	P3461	U16	Deg	Auto-guidance mode - Maximum allowed wheel angle at the vehicle speed of 0 km/h	OEM	0	89	35	S
GPS - Vehicle speed limiting wheel angle @ Point H	P3463	U16	km/h	Auto-guidance mode - Vehicle speed at which the flow should be limited to "GPS - Max wheel @ Point H"	OEM	0	100	15	S
GPS - Max wheel angle @ Point H	P3465	U16	Deg	Auto-guidance mode - Maximum allowed wheel angle at the vehicle speed "GPS - Vehicle speed limiting @ Point H"	OEM	0	89	15	S
GPS - Vehicle speed limiting wheel angle @ Point I	P3467	U16	km/h	Auto-guidance mode - Vehicle speed at which the flow should be limited to "GPS - Max wheel @ Point I"	OEM	0	100	25	S
GPS - Max wheel angle @ Point I	P3469	U16	Deg	Auto-guidance mode - Maximum allowed wheel angle at the vehicle speed "GPS - Vehicle speed limiting @ Point I"	OEM	0	89	10	S

Table 55



12.5 VEHICLE SPEED DEPENDENT CLOSED LOOP CONTROL

As each application is different, Danfoss has implemented a speed dependent closed loop control gain, configurable for each Auto-guidance controller (hence individual parameters for both GPS and GPS2). When using an auto-guidance function, the PVED-CLS's Auto-guidance control algorithm can vary the closed loop gain, dependent on the vehicle speed.

GPS

The range is from 0 to 100 km/h for P3479 to P3483 and from 0 to 200 [%] for P3473 to P3478.

GPS2

The range is from 0 to 100 km/h for P3491 to P3495 and from 0 to 200 [%] for P3485 to P3490.

These parameters represent the six points on the curve below (Point P, Q, R, S, T and U). The Auto-guidance algorithm will make linear interpolation in between each of the six points. It is allowed to move the six points in any direction, limited by the following rules:

- Point P is always specified at Vehicle speed = 0 km/h
- The Vehicle speed has to increase for each point, hence "Vehicle speed" for Point P < "Vehicle speed" for Point Q AND "Vehicle speed" for Point Q < "Vehicle speed" for Point R AND "Vehicle speed" for Point R < "Vehicle speed" for Point S etc....
- Point U "Closed loop gain" is valid for Point U "Vehicle speed" and vehicle speeds above Point U "Vehicle speed"

Important

Danfoss recommends using fixed gain. Use speed dependent gain only if necessary.

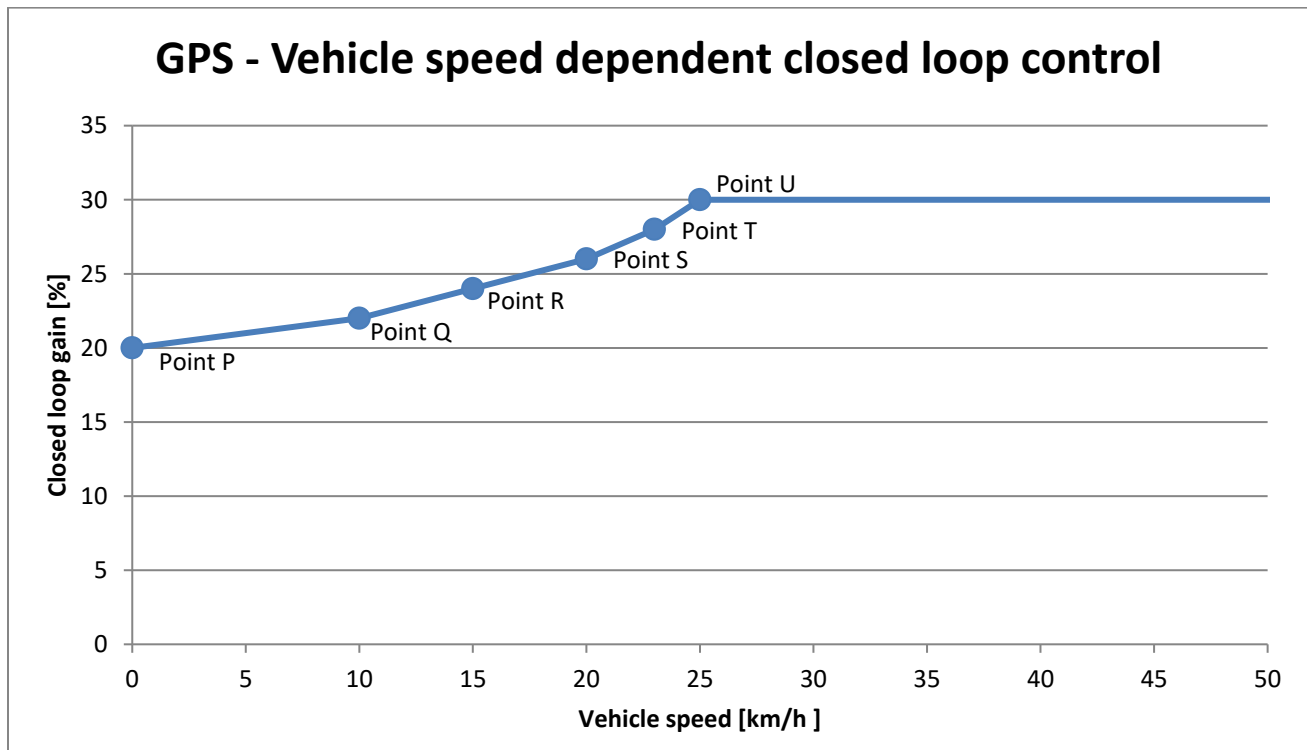

Figure 67



Warning



Setting the closed loop gain at a too high level could give unwanted aggressive steering behavior in auto-guidance mode, especially in combination with a low vehicle speed this could lead to unwanted aggressive steering behavior when acquiring a line!

Important

If the GPS algorithm type is changed, then it might be necessary to adjust GPS gain parameter

Name	Address	Data type	Unit	Description of parameter	User	Range		Danfoss default value	Safety critical parameters 'S'
						Min.	Max.		
GPS – CL gain @ Point P	P3473	U8	%	Auto-guidance mode - Close loop proportional gain at 0 km/h	OEM	0	200	50	S
GPS – CL gain @ Point Q	P3474	U8	%	Auto-guidance mode - Close loop proportional gain at "GPS – Vehicle speed @ Point Q"	OEM	0	200	50	S
GPS – CL gain @ Point R	P3475	U8	%	Auto-guidance mode - Close loop proportional gain at "GPS – Vehicle speed @ Point R"	OEM	0	200	50	S
GPS – CL gain @ Point S	P3476	U8	%	Auto-guidance mode - Close loop proportional gain at "GPS – Vehicle speed @ Point S"	OEM	0	200	50	S
GPS – CL gain @ Point T	P3477	U8	%	Auto-guidance mode - Close loop proportional gain at "GPS – Vehicle speed @ Point T"	OEM	0	200	50	S
GPS – CL gain @ Point U	P3478	U8	%	Auto-guidance mode - Close loop proportional gain at "GPS – Vehicle speed @ Point U"	OEM	0	200	50	S
GPS – Vehicle speed @ Point Q	P3479	U8	km/h	Auto-guidance mode – Vehicle speed at "GPS – CL gain @ Point Q"	OEM	0	100	30	S
GPS – Vehicle speed @ Point R	P3480	U8	km/h	Auto-guidance mode – Vehicle speed at "GPS – CL gain @ Point R"	OEM	0	100	31	S
GPS – Vehicle speed @ Point S	P3481	U8	km/h	Auto-guidance mode – Vehicle speed at "GPS – CL gain @ Point S"	OEM	0	100	32	S
GPS – Vehicle speed @ Point T	P3482	U8	km/h	Auto-guidance mode – Vehicle speed at "GPS – CL gain @ Point T"	OEM	0	100	33	S
GPS – Vehicle speed @ Point U	P3483	U8	km/h	Auto-guidance mode – Vehicle speed at "GPS – CL gain @ Point U"	OEM	0	100	34	S
GPS2 – CL gain @ Point P	P3485	U8	%	Auto-guidance mode for second Auto-guidance controller - Close loop proportional gain at 0 km/h	OEM	0	200	50	S
GPS2 – CL gain @ Point Q	P3486	U8	%	Auto-guidance mode for second Auto-guidance mode - Close loop proportional gain at "GPS2 – Vehicle speed @ Point Q"	OEM	0	200	50	S
GPS2 – CL gain @ Point R	P3487	U8	%	Auto-guidance mode for second Auto-guidance mode - Close loop proportional gain at "GPS2 – Vehicle speed @ Point R"	OEM	0	200	50	S
GPS2 – CL gain @ Point S	P3488	U8	%	Auto-guidance mode for second Auto-guidance mode - Close loop proportional gain at "GPS2 – Vehicle speed @ Point S"	OEM	0	200	50	S



GPS2 – CL gain @ Point T	P3489	U8	%	Auto-guidance mode for second Auto-guidance mode - Close loop proportional gain at “GPS2 – Vehicle speed @ Point T”	OEM	0	200	50	S
GPS2 – CL gain @ Point U	P3490	U8	%	Auto-guidance mode for second Auto-guidance mode - Close loop proportional gain at “GPS2 – Vehicle speed @ Point U”	OEM	0	200	50	S
GPS2 – Vehicle speed @ Point Q	P3491	U8	km/h	Auto-guidance mode for second Auto-guidance mode – Vehicle speed at “GPS2 – CL gain @ Point Q”	OEM	0	100	30	S
GPS2 – Vehicle speed @ Point R	P3492	U8	km/h	Auto-guidance mode for second Auto-guidance mode – Vehicle speed at “GPS2 – CL gain @ Point R”	OEM	0	100	31	S
GPS2 – Vehicle speed @ Point S	P3493	U8	km/h	Auto-guidance mode for second Auto-guidance mode – Vehicle speed at “GPS2 – CL gain @ Point S”	OEM	0	100	32	S
GPS2 – Vehicle speed @ Point T	P3494	U8	km/h	Auto-guidance mode for second Auto-guidance mode – Vehicle speed at “GPS2 – CL gain @ Point T”	OEM	0	100	33	S
GPS2 – Vehicle speed @ Point U	P3495	U8	km/h	Auto-guidance mode for second Auto-guidance mode – Vehicle speed at “GPS2 – CL gain @ Point U”	OEM	0	100	34	S

Table 56



12.6 VEHICLE SPEED DEPENDENT FLOW COMMAND LIMITATION

GPS algorithm type = GPS v1

Using the auto-guidance function, the PVED-CLS’s auto-guidance control algorithm can also limit the maximum allowed output flow in proportion to the vehicle speed (i.e. the faster the vehicle goes the lower the maximum allowed flow will be).

Speed range [km/h]: 0 to 100 for P3453 and P3457

Range [IR]: 0 to 1000 for P3451, P3455 and P3459

Important

This function applies to both GPS and GPS2.

These parameters represent the three points on the curve below (Point D, E and F). The auto-guidance algorithm will make linear interpolation in between each of the three points. It is allowed to move the three points in any direction, limited by the following rules:

- Point D is always specified at Vehicle speed limited flow = 0 km/h
- Point F “Max flow” is valid for Point F and vehicle speeds above Point F
- Point D “Max flow” ≥ Point E “Max flow” ≥ Point F “Max flow”
- Point F “Vehicle speed limited flow” > Point E “Vehicle speed limited flow” > Point D “Vehicle speed limited flow”

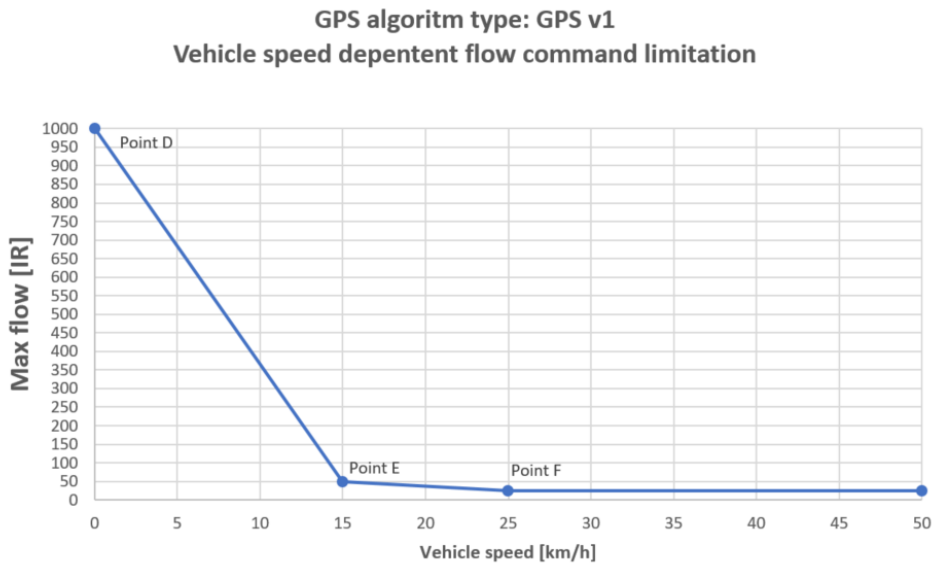

Figure 68

Warning



Failure to comply with the above rules may render this function inoperable or lead to undesirable steering behavior!



Name	Address	Data type	Unit	Description of parameter	User	Range		Danfoss default value	Safety critical parameters 'S'
						Min.	Max.		
GPS - Max flow @ Point D	P3451	U16	IR	Auto-guidance mode Maximum allowed flow at the vehicle speed of 0 km/h	OEM	0	1000	1000	S
GPS - Vehicle speed limiting flow @ Point E	P3453	U16	km/h	Auto-guidance mode Vehicle speed at which the flow should be limited to @ Point E	OEM	0	100	15	S
GPS - Max flow @ Point E	P3455	U16	IR	Auto-guidance mode Maximum allowed flow at the vehicle speed @ Point E	OEM	0	1000	50	S
GPS - Vehicle speed limiting flow @ Point F	P3457	U16	km/h	Auto-guidance mode Vehicle speed at which the flow should be limited to @ Point F	OEM	0	100	25	S
GPS - Max flow @ Point F	P3459	U16	IR	Auto-guidance mode Maximum allowed flow at the vehicle speed @ Point F	OEM	0	1000	25	S

Table 57



12.7 VEHICLE SPEED DEPENDENT WHEEL ANGLE SPEED LIMITATION

GPS algorithm type = GPS v2

Using the auto-guidance function, the PVED-CLS’s auto-guidance control algorithm can also limit the maximum allowed wheel angle speed in proportion to the vehicle speed (i.e. the faster the vehicle goes the lower the maximum wheel angle speed will be).

Speed range [km/h]: 0 to 100 for P3453 and P3457

Range [dDeg/s]: 0 to 1000 for P3451, P3455 and P3459

Important

This function applies to both GPS and GPS2.

These parameters represent the three points on the curve below (Point D, E and F). The auto-guidance algorithm will make linear interpolation in between each of the three points. It is allowed to move the three points in any direction, limited by the following rules:

- Point D is always specified at Vehicle speed limited flow = 0 km/h
- Point F “Max wheel angle speed” is valid for Point F and vehicle speeds above Point F
- Point D “Max wheel angle speed” ≥ Point E “Max wheel angle speed” ≥ Point F “Max wheel angle speed”
- Point F “Vehicle speed limited wheel angle speed” > Point E “Vehicle speed limited wheel angle speed” > Point D “Vehicle speed limited wheel angle speed”

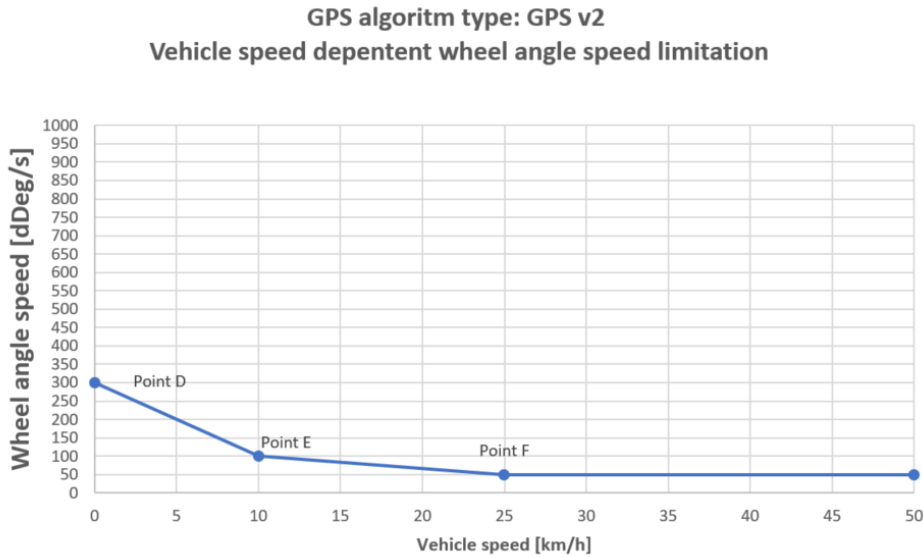

Figure 69

Warning



Failure to comply with the above rules may render this function inoperable or lead to undesirable steering behavior!



Name	Address	Data type	Unit	Description of parameter	User	Range		Danfoss default value	Safety critical parameters 'S'
						Min.	Max.		
GPS - Max wheel angle speed @ Point D	P3451	U16	dDeg/s	Auto-guidance mode Maximum allowed wheel angle speed at the vehicle speed of 0 km/h, @ Point D	OEM	0	1000	1000	S
GPS - Vehicle speed limiting wheel angle speed @ Point E	P3453	U16	km/h	Auto-guidance mode Vehicle speed at which the wheel angle speed should be limited, @ Point E	OEM	0	100	15	S
GPS - Max wheel angle speed @ Point E	P3455	U16	dDeg/s	Auto-guidance mode Maximum allowed wheel angle speed @ Point E	OEM	0	1000	50	S
GPS - Vehicle speed limiting wheel angle speed @ Point F	P3457	U16	km/h	Auto-guidance mode Vehicle speed at which the wheel angle speed should be limited @ Point F	OEM	0	100	25	S
GPS - Max wheel angle speed @ Point F	P3459	U16	dDeg/s	Auto-guidance mode Maximum allowed wheel angle speed @ Point F	OEM	0	1000	25	S

Table 58



13 Safe on-road mode

Controlling an OSPE, EHPS or EHi valve with a PVED-CLS is designed for off-road use only. When the vehicle is taken from an off-road situation to an on-road situation, a common risk mitigation method is to power off the PVED-CLS.

If powering off the PVED-CLS is not feasible, Danfoss has implemented an option to use the PVED-CLS to broadcast wheel angle position on the CAN bus. This functionality will do a soft shut down of the PVED-CLS, to fulfill that the PVED-CLS is active for broadcasting signals on the CAN bus, when driving on road, but no controlling of the EH is available (hence SVB and Cut-off valve are off).

For more details on how to setup this architecture and the PVED-CLS, please see the Danfoss document, PVED-CLS Safety Manual.

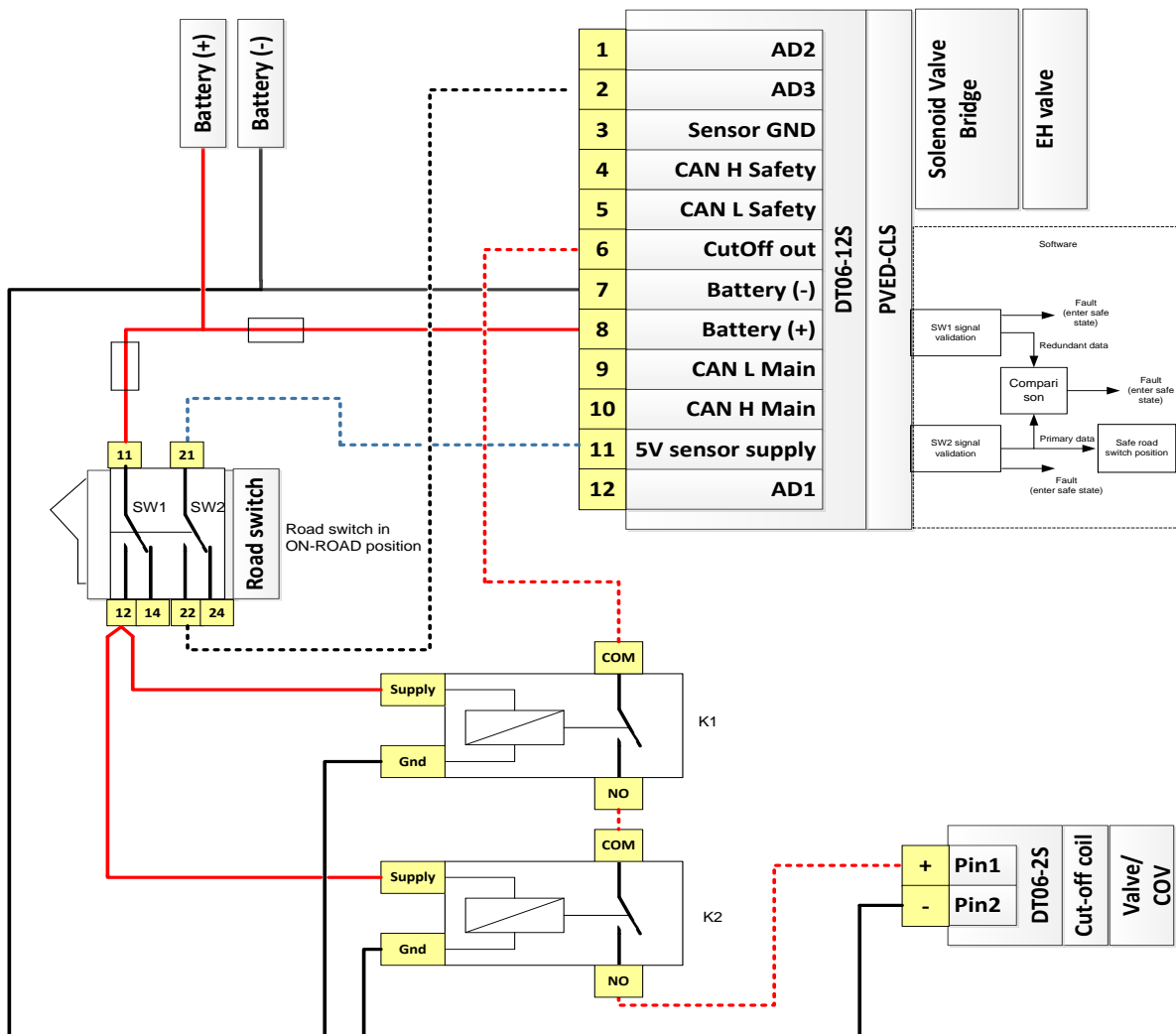

Figure 70



14 FDA

FDA – Fault Detection Algorithm is a safety function, which can be used to monitor the system behavior and check if the steering wheel movements, spool position and the wheel angle changes are consistent with each other. To learn more about the safety aspect in this functionality, please see the Danfoss document, PVED-CLS Safety Manual.

The FDA functions are only available when both SASA and WAS are present in the system. In a system where the SASA or WAS are not present, the parameter Safe state upon a failure detection (P3132) must be set to disabled, otherwise the PVED-CLS will enter safe state. No safety impact.

The FDA evaluation is done in 3 steps:

First step: Sensor validation

The input sensors are evaluated using the thresholds defined by parameters in the FDA sector.

For STW it is determined whether its turning left, not turning or turning right by using parameters P3122 & P3133.

For WAS it is determined whether the vehicle is turning left, not turning or turning right by using parameters P3123 & P3124.

For the spool position sensor (LVDT) it is determined whether it is outside left dead-band, inside both dead-bands or outside right dead-band by using the closed loop dead-bands + P3128 & P3130.

The results of these evaluations are found in status message 5, byte 1, bits 8 – 3.

Second step: System evaluation

With the information from the sensors the FDA validates whether the state of the system is OK (Yes) or not OK (No) by using the following truth table:

Sensor validation	Condition								
Spool position	Left	Left	Left	Neutral	Neutral	Neutral	Right	Right	Right
Steering wheel direction	Left	Neutral	Right	Left	Neutral	Right	Left	Neutral	Right
WAS direction = Left	Yes	Yes	No	Yes	No	No	No	No	No
WAS direction = Neutral and cylinder close to left end-stop (WAS IR < -950)	Yes	Yes	No	Yes	Yes	No	No	No	No
WAS direction = Neutral and cylinder not close to end stop (WAS IR ≤ 950)	No	No	No	No	Yes	No	No	No	No
WAS direction = Neutral and cylinder close to right end-stop (WAS IR > 950)	No	No	No	No	Yes	Yes	No	Yes	Yes
WAS direction = Right	No	No	No	No	No	Yes	No	Yes	Yes

Table 59

Whenever the FDA detects a “not OK” condition, the error condition flag is set. The error condition flag is found in status message 5, byte 1, bits 2 – 1.

Third step: confidence counter

Whenever the FDA detects an error condition, the confidence counter is incremented by 10ms (the validation is done every 10ms). If the system is in a good condition, the confidence counter is decremented by 10ms*P3125.

If the confidence counter is greater than equal to P3126, the fault condition flag is set and PVED-CLS enters safe state (unless disabled by parameter P3132). The fault condition flag is found in status message 5, byte 2, bits 2 – 1.



Warning



DISABLE of FDA (P3132 set to 0) should only be used when diagnosis of the wheel angle sensor and SASA failure modes are ensured by another monitoring function or when getting initial data for FDA tuning.

Important

FDA parameter settings are not to be tuned manually. They are obtained by parameter training with a PC tool. The PC tool requires CAN data from actual driving with the machine in all working modes to train the algorithm for good parameters.

To perform the training the following is needed:

- CAN log with status message 5 @ 10ms, both MAIN and SAFETY
- Parameter settings from the FDA and spool calibration sectors.

Event triggered CAN loggers are useful here, in field testing. They can be used to obtain only data when FDA is failing or close to failing, so additional training can be done on those situations.

At present the training tool is not released, therefore contact your local technical support at Danfoss Power Solutions.



Name	Address	Data type	Unit	Description of parameter	User	Range		Danfoss default value	Safety critical parameters 'S'
						Min.	Max.		
Fault Detection Algorithm - Steering wheel activation velocity threshold	P3122	U8	dRpm	Steering wheel angle velocity threshold used in the Fault Detection Algorithm to detect the steering wheel activation	OEM	0	150	5	S
Fault Detection Algorithm - min. wheel angle movement threshold	P3123	U8	IR	Minimum wheel angle difference necessary to observe in order to make the Fault Detection Algorithm assume that the wheels are moving	OEM	0	200	50	S
Fault Detection Algorithm - wheel angle sensor delay	P3124	U8	x10mSec	Number of loops between samples that are being compared against next parameter or WA motion determination	OEM	1	20	1	S
Fault Detection Algorithm - Fault confidence counter decrease rate	P3125	U8	x10mSec	Rate at which the Fault Detection Algorithm confidence counter value decreases if an error is no longer observed	OEM	1	10	1	S
Fault Detection Algorithm - Fault confidence counter timeout	P3126	U16	x10mSec	Time period for which error shall be observed by FDA to report failure	OEM	0	2000	50	S
Fault Detection Algorithm - Spool in left position range offset	P3128	S16	x10u Meter	Distance from closed loop dead-band to check if spool in left side	OEM	-200	200	0	S
Fault Detection Algorithm - Spool in right position range offset	P3130	S16	x10u Meter	Distance from closed loop dead-band to check if spool in right side	OEM	-200	200	0	S
Fault Detection Algorithm - Safe state upon a failure detection	P3132	U8	-	<p>FDA safe state trigger Enable/Disable after failure detection. Valid Values: 0 (DISABLE); 255 (ENABLE)</p> <p>Warning</p>  <p>DISABLE should only be used when diagnosis of the wheel angle sensor and SASA failure modes are ensured by another monitoring function or when getting initial data for FDA tuning</p>	OEM	0	255	0	S
Fault Detection Algorithm - Backlash region	P3133	U8	dDeg	Backlash limit to use in the backlash filter in the FDA control algorithm exclusively Resolution: 1dDeg = 0.1Deg	OEM	0	200	5	S
Fault Detection Algorithm - Vehicle speed threshold for EHPS	P3134	U8	km/h	Will disable the FDA and spool monitoring if speed of the vehicle goes below this value. Should only be changed if EHPS/OSPE system is underpowered, hence the system does not have enough pressure to move the wheels (normally when vehicle is not moving)	OEM	0	10	0	S

Table 60



15 Diagnostics and troubleshooting

15.1 DIAGNOSTICS

All detected faults, except faults with severity level INFO, will bring the PVED-CLS in to its safe state. Going into safe state infers that the SVB and cut-off valve is de-energized. Any fault that brings the PVED-CLS in safe state are stored in the PVED-CLS' error buffer for diagnostic purposes. The Danfoss Plus+1 Service Tool can be used to read out the error-history or send DM2.

The PVED-CLS may be accessed via CAN for diagnostic purposes while being in safe state but parameter configuration is not possible in safe state. Parameter configuration is only possible in "bootloader-mode"!

If the fault is related to the sensors or CAN bus cable tree, these faults should be resolved and the PVED-CLS should be powered up again. If the fault requires parameters to be changed, the PVED-CLS must be brought into "bootloader-mode" before re-configuring the parameters.

Example on resolving a fault

A redundant wheel angle sensor is mapped as present (i.e. P3245 is set to 255) but does not exist in the system. The PVED-CLS will boot, but go directly to safe state during safety checks, due to the missing wheel angle sensor.

Solution

The PVED-CLS needs to run in "bootloader-mode" before any parameter may be changed i.e. power up the PVED-CLS in "bootloader-mode" (see the Danfoss document, PVED-CLS KWP2000 protocol) and set the parameter P3245 to 0 (i.e. redundant WAS not present) or mount a redundant sensor in the system and reboot the PVED-CLS.

The PVED-CLS software performs diagnostic checks on the CAN bus interface, analogue sensors, SVB interface, internal hardware peripherals and software execution plausibility. All detected faults, except faults with severity level INFO, will bring the PVED-CLS in to its safe state. Secondly, the diagnostic checks provide precise indication of the fault source and thus reduce system down-time.

However, not all unexpected system behavior can be traced via error codes. E.g. a too low gain-related parameter value may result in too slow steering actuation but this cannot be detected as a fault. To rule out faults resulting from conflicting system and parameter settings, the following trouble shooting steps are recommended:

- Check the list of typical faults first (see paragraph 15.2)
- Check the J1939 Diagnostic interface
- Check the PVED-CLS LED diagnostic interface (see paragraph 5.2)



15.2 TROUBLESHOOTING – TYPICAL FAULTS

Symptom	PVED-CLS operational status	Cause/solution
No actuation (neither by AUX-steering and auto-guidance-steering)	Operational	<ol style="list-style-type: none"> No or insufficient pressure is supplied to the valve. No Auto-guidance controller or AUX-steering device is mapped Flow/angle limited parameters set to ~0 No or incorrect auto-steering message from external set-point controller System is in road mode
	Fault	<ol style="list-style-type: none"> Any missing or incorrect input signal/message + wrong parameterization from steering sensors/switches at the AD1, AD2, AD3 or CAN interface. Insufficient electrical power supply to the PVED-CLS Connector or wiring harness problem Missing wheel angle- or valve calibration
	No status available	<ol style="list-style-type: none"> CAN bus not operational. Check connection. No electric power supply Check CAN message addresses PVED-CLS is damaged. (see 5.2)
Opposite actuation	Operational	<ol style="list-style-type: none"> Hoses between valve and steering actuator are swapped Parameter; Invert Flow Direction; (P3080), is set to 255 and PVED-CLS is mounted on a OSPE/EHi or P3080 is set to 0 and PVED-CLS is mounted on a EHPS
Slow actuation responds (delays)	Operational	<ol style="list-style-type: none"> Air is trapped in the steering actuator or hoses. Oil has high viscosity. Make sure to apply to the technical requirements listed in the Danfoss document OSPE Steering valve, SASA sensor, Technical information The requested pressure is supplied with some delay (Pump).
Snake-movement or shaky-movement in auto-guidance mode	Operational	<ol style="list-style-type: none"> Shaky-movement: The Open loop dead-band parameters P1 and/or P2 (P1: P3166 + P3170; P2: P3168 + P3170) is set too aggressive (in flow range) or the Closed loop dead-band edge, Left/Right (P3166 and P3168) are set too conservative (inside hydraulic dead-band) Snake-movement: The Open loop dead-band parameters P1 and/or P2 (P1: P3166 + P3170; P2: P3168 + P3170) is set too conservative (inside hydraulic dead-band) or the Closed loop dead-band edge, Left/Right (P3166 and P3168) are set too aggressive (in flow range)
Actuation with low gain (less flow than expected)	Operational	<ol style="list-style-type: none"> The offset dead-band CL parameter (P3170) is set too low (inside dead-band) or the left/right dead-band OL parameters (P3166 and P3168) are set too low (inside dead-band). The parameters for setting up a steering wheel program (P3522 to P3561) are set too high Parameter; OSP displacement (P3084) is set greater than the true displacement of the OSP Parameter Valve capacity (P3088) is set greater than the true flow capacity of the valve Parameters Max Spool Position Let/Right (P3162/P3164) is set too low The soft-stop functionality limits the flow due to wrong settings (P3564 and P3566)
	Fault	<ol style="list-style-type: none"> The hydraulic back-up system is active. The steering sensitivity is determined by the OSP.
PVED-CLS does not enter normal operation and stays in bootloader after software download	Fault	<ol style="list-style-type: none"> Wrong software downloaded to one of the microcontrollers inside PVED-CLS. Make sure the correct software is downloaded to the correct controller

Table 61



16 Errata information

The latest errata information is always available on the Danfoss homepage via following link:

[HTTP://POWERSOLUTIONS.DANFOSS.COM/PRODUCTS/STEERING/PVED-CLS-INTELLIGENT-STEERING-SUB-SYSTEM/](http://powersolutions.danfoss.com/products/steering/pved-cls-intelligent-steering-sub-system/)

It contains errata information for:

- PVED-CLS boot loader
- PVED-CLS application
- Documentation
- PLUS+1 Service tool
- Other topics related to the steering system

If further information to any errata is required, please contact your nearest Danfoss Product Application Engineer

Attention



- **The system integrator and/or responsible for the target system is advised to periodically observe the errata information as new information will be added as needed.**
- **Optionally, the system integrator and responsible for the system, after commissioning, may sign up for the email notification service.**



17 Appendix

17.1 PARAMETER CROSS CHECK

Error No.	Addresses	Name	Sector Name	Cross Check Condition	SPN	FMI list
1	3254	Disengage Method	Peripherals Config	1. If Disengage Method (P3254) is IMD : Valve_Type (P3081) should be = EHi-H (2), Fault Detection Algorithm - Safe state upon a failure detection (P3132) should be = 0, IMD - EH-Spool in neutral confidence limit should be less than IMD - EH-Steering disengage confidence limit 2. If Disengage Method (P3254) = SASA: Valve Type should not be (P3081) = EHi-H (2)	520246	31
	3081	Valve Type	Hydraulic Config			
	3132	Fault Detection Algorithm - Safe state upon a failure detection	SEHS FDA			
	3587	IMD - EH-Spool in neutral confidence limit	STW Config			
	3586	IMD - EH-Steering disengage confidence limit	STW Config			
2	3239	AUX Present	Peripherals Config	If Aux Present (P3239)= TRUE & Aux Type (P3240)= Analog Joystick: WAS Interface cannot be Analog and vice versa	520246	31
	3240	AUX Type	Peripherals Config			
	3244	WAS interface	Peripherals Config			
3	3244	WAS interface	Peripherals Config	If WAS Interface(P3244) = NONE: STW anti-drift - Max flow correction in percentage of full flow (P3569) & AUX anti-drift - Max flow correction in percentages of full flow (P3705) should be = 0, Valve type (P3081) should not be = EHPS (1), GPS Present (P3237) & GPS2 Present (P3238) should be = FALSE, If AUX Present(P3239) = TRUE, then AUX Type (P3240) should not be = AUX Closed Loop Joystick, Fault Detection Algorithm - Safe state upon a failure detection (P3132) should be = 0	520246	31
	3081	Valve type	Hydraulic Config			
	3569	STW anti-drift - Max flow correction in percentage of full flow	STW Config			
	3705	AUX anti-drift - Max flow correction in percentages of full flow	AUX Config			
	3237	GPS present	Peripherals Config			
	3238	GPS2 present	Peripherals Config			
	3239	AUX present	Peripherals Config			
	3240	AUX type	Peripherals Config			
	3132	Fault Detection Algorithm - Safe state upon a failure detection	SEHS FDA			
	3254	EH-Steering disengage method	Peripherals Config			
4	3245	Redundant WAS present	Peripherals Config	1. If WAS Interface (P3244) = Analog, Or AUX Present (P3239)= TRUE & AUX Type (P3240) = AUX Analog Joystick: Primary analogue sensor max left position (P3205) < Primary analogue sensor neutral position (P3209) & Primary analogue sensor neutral position (P3209) < Primary analogue sensor max right position (P3207), Or Primary analogue sensor max left position (P3205) > Primary analogue sensor neutral position (P3209) & Primary analogue sensor neutral position (P3209) > Primary analogue sensor max right position (P3207), 2. If WAS Interface (P3244) = Analog & Redundant WAS present (P3245)= TRUE: Redundant analogue sensor max left position (P3211) < Redundant analogue sensor neutral position (P3215) & Redundant analogue sensor neutral position (P3215) < Redundant analogue sensor max right position (P3213), Or	520236	2
	3239	AUX present	Peripherals Config			
	3240	AUX type	Peripherals Config			
	3244	WAS interface	Peripherals Config			
	3205	Primary analogue sensor max left position	Analog Sensor Calibration Data			
	3207	Primary analogue sensor max right position	Analog Sensor Calibration Data			
	3209	Primary analogue sensor neutral position	Analog Sensor Calibration Data			



	3211	Redundant analogue sensor max left position	Analog Sensor Calibration Data	Redundant analogue sensor max left position (P3211) > Redundant analogue sensor neutral position (P3215) & Redundant analogue sensor neutral position (P3215) > Redundant analogue sensor max right position (P3213)		
	3213	Redundant analogue sensor max right position	Analog Sensor Calibration Data			
	3215	Redundant analogue sensor neutral position	Analog Sensor Calibration Data			
5	3239	AUX present	Peripherals Config	If WAS interface = CAN(P3244): WAS max left position (CAN) (P3185) < WAS neutral position (CAN) (P3189) < WAS max right position (CAN) (P3187), Or WAS max left position (CAN) (P3185) > WAS neutral position (CAN) (P3189) > WAS max right position (CAN) (P3187)	520235	2
	3240	AUX type	Peripherals Config			
	3244	WAS interface	Peripherals Config			
	3185	WAS max left position (CAN)	CAN WAS Calibration Data			
	3187	WAS max right position (CAN)	CAN WAS Calibration Data			
	3189	WAS neutral position (CAN)	CAN WAS Calibration Data			
6	3453	GPS - Vehicle speed limiting flow @ Point E	GPS Config	0 < GPS - Vehicle speed limiting flow @ Point E (P3453) < GPS - Vehicle speed limiting flow @ Point F (P3457)	520242	2
	3457	GPS - Vehicle speed limiting flow @ Point F	GPS Config			
7	3463	GPS - Vehicle speed limiting wheel angle @ Point H	GPS Config	0 < GPS - Vehicle speed limiting wheel angle @ Point H (P3463) < GPS - Vehicle speed limiting wheel angle @ Point I (P3467)	520242	2
	3467	GPS - Vehicle speed limiting wheel angle @ Point I	GPS Config			
8	3479	GPS - Vehicle speed @ Point Q	GPS Config	0 < GPS - Vehicle speed @ Point Q (P3479) < GPS - Vehicle speed @ Point R (P3480) < GPS - Vehicle speed @ Point S (P3481) < GPS - Vehicle speed @ Point T (P3482) < GPS - Vehicle speed @ Point U (P3483)	520242	2
	3480	GPS - Vehicle speed @ Point R	GPS Config			
	3481	GPS - Vehicle speed @ Point S	GPS Config			
	3482	GPS - Vehicle speed @ Point T	GPS Config			
	3483	GPS - Vehicle speed @ Point U	GPS Config			
9	3491	GPS2 - Vehicle speed @ Point Q	GPS Config	0 < GPS2 - Vehicle speed @ Point Q (P3491) < GPS2 - Vehicle speed @ Point R (P3492) < GPS2 - Vehicle speed @ Point S (P3493) < GPS2 - Vehicle speed @ Point T (P3494) < GPS2 - Vehicle speed @ Point U (P3495)	520242	2
	3492	GPS2 - Vehicle speed @ Point R	GPS Config			
	3493	GPS2 - Vehicle speed @ Point S	GPS Config			
	3494	GPS2 - Vehicle speed @ Point T	GPS Config			
	3495	GPS2 - Vehicle speed @ Point U	GPS Config			
10	3528	STW 1 - Vehicle speed @ Point B	STW Config	0 < STW 1 - Vehicle speed @ Point B (P3528) < STW 1 - Vehicle speed @ Point C (P3529)	520243	2
	3529	STW 1 - Vehicle speed @ Point C	STW Config			
11	3536	STW 2 - Vehicle speed @ Point B	STW Config	0 < STW 2 - Vehicle speed @ Point B (P3536) < STW 2 - Vehicle speed @ Point C (P3537)	520243	2
	3537	STW 2 - Vehicle speed @ Point C	STW Config			
12	3544	STW 3 - Vehicle speed @ Point B	STW Config	0 < STW 3- Vehicle speed @ Point B (P3544) < STW 3 - Vehicle speed @ Point C (P3545)	520243	2
	3545	STW 3 - Vehicle speed @ Point C	STW Config			
13	3552	STW 4 - Vehicle speed @ Point B	STW Config	0 < STW 4- Vehicle speed @ Point B < STW 4 - Vehicle speed @ Point C (P3553)	520243	2
	3553	STW 4 - Vehicle speed @ Point C	STW Config			
14	3560	STW 5 - Vehicle speed @ Point B	STW Config	0 < STW 5 - Vehicle speed @ Point B (P3560) < STW 5 - Vehicle speed @ Point C (P3561)	520243	2



	3561	STW 5 - Vehicle speed @ Point C	STW Config			
15	3656	AUX mini-steering 1 - Vehicle speed @ Point K	AUX Config	0 < AUX mini-steering 1 - Vehicle speed @ Point K (P3656) < AUX mini-steering 1 - Vehicle speed @ Point L (P3657)	520244	2
	3657	AUX mini-steering 1 - Vehicle speed @ Point L	AUX Config			
16	3664	AUX mini-steering 2 - Vehicle speed @ Point K	AUX Config	0 < AUX mini-steering 2 - Vehicle speed @ Point K < AUX mini-steering 2 - Vehicle speed @ Point L (P3665)	520244	2
	3665	AUX mini-steering 2 - Vehicle speed @ Point L	AUX Config			
17	3672	AUX mini-steering 3 - Vehicle speed @ Point K	AUX Config	0 < AUX mini-steering3 - Vehicle speed @ Point K (P3672) < AUX mini-steering 3 - Vehicle speed @ Point L (P3673)	520244	2
	3673	AUX mini-steering 3 - Vehicle speed @ Point L	AUX Config			
18	3680	AUX mini-steering 4 - Vehicle speed @ Point K	AUX Config	0 < AUX mini-steering 4 - Vehicle speed @ Point K (P3680) < AUX mini-steering 4- Vehicle speed @ Point L (P3681)	520244	2
	3681	AUX mini-steering 4 - Vehicle speed @ Point L	AUX Config			
19	3688	AUX mini-steering 5 - Vehicle speed @ Point K	AUX Config	0 < AUX mini-steering 5 - Vehicle speed @ Point K (P3688) < AUX mini-steering 5 - Vehicle speed @ Point L (P3687)	520244	2
	3687	AUX mini-steering 5 - Vehicle speed @ Point L	AUX Config			
20	3734	AUX joystick - Maximum deflection region offset	AUX Config	AUX joystick - Maximum deflection region offset (P3734) ≤ (1000 - AUX joystick - Interpolation point X for open loop joystick transfer function) (P3738), 0 ≤ AUX joystick - Interpolation point X for open loop joystick transfer function (P3738) ≤ 1000, 0 ≤ AUX joystick - Interpolation point Y for open loop joystick transfer function (P3740) ≤ 1000, AUX joystick - Dead-band region (P3736) ≤ AUX joystick - Interpolation point X for open loop joystick transfer function (P3738)	520244	2
	3736	AUX joystick - Dead-band region	AUX Config			
	3738	AUX joystick - Interpolation point X for open loop joystick transfer function	AUX Config			
	3740	AUX joystick - Interpolation point Y for open loop joystick transfer function	AUX Config			
21	3241	Road switch present (connected to AD3)	Peripherals Config	If Cut-off valve present (P3072) = TRUE, Road switch resistance check (P3242) should be = FALSE If Road switch present (connected to AD3) (P3241) = FALSE, Road switch resistance check P3242) should be = FALSE	520237	2
	3242	Road switch resistance check	Peripherals Config			
	3072	Cut-off valve present	Hydraulic Config			
22	3311	PGN offset to operation status messages	SEHS Protocol Data	All PGN offsets shall differ from each other (MMI_PGN_OFFSET shall be checked as well, if MMI_PGN_TYPE is set to ProprietaryB).	520238	2
	3312	PGN offset to status message 1	SEHS Protocol Data			
	3313	PGN offset to status message 2	SEHS Protocol Data			
	3314	PGN offset to status message 3	SEHS Protocol Data			
	3315	PGN offset to status message 4	SEHS Protocol Data			
	3316	PGN offset to status message 5	SEHS Protocol Data			
	3317	PGN offset to status message 6	SEHS Protocol Data			
	3328	PGN offset to Status message 7	SEHS Protocol Data			
	3332	PGN offset to Status message 8	SEHS Protocol Data			
	3318	PGN offset to vehicle speed sensor message	SEHS Protocol Data			
	3319	PGN offset to steering wheel sensor messages	SEHS Protocol Data			
	3320	PGN offset to wheel angle sensor messages	SEHS Protocol Data			
	3321	PGN offset to AUX mini-steering wheel messages	SEHS Protocol Data			
	3322	PGN offset to AUX joystick messages	SEHS Protocol Data			
	3323	PGN offset to steering feedback message	SEHS Protocol Data			
3325	PGN offset to MMI message	SEHS Protocol Data				
3324	PGN type for MMI message	SEHS Protocol Data				
23	3426	Maximum steer angle, left	Vehicle Geometry	If WAS interface (P3244)= ANALOG: Maximum steer angle, left (P3426) ≤ 89 & Maximum steer angle, right (P3428) ≤ 89, Or Automatically adjusted maximum steer angle to left side (analogue WAS) (P3223) ≤ 89 & Automatically adjusted maximum steer angle to right side (analogue WAS) (P3225) ≤ 89	520241	2
	3428	Maximum steer angle, right	Vehicle Geometry			
	3244	WAS interface	Peripherals Config			



	3223	Automatically adjusted maximum steer angle to left side (analogue WAS)	Analog Sensor Calibration Data			
	3225	Automatically adjusted maximum steer angle to right side (analogue WAS)	Analog Sensor Calibration Data			
24	3426	Maximum steer angle, left	Vehicle Geometry	If WAS interface (P3244) = CAN: Maximum steer angle, left (P3426) ≤ 89 & Maximum steer angle, right (P3428) ≤ 89, Or Automatically adjusted maximum steer angle to left side (CAN WAS) (P3193) ≤ 89 & Automatically adjusted maximum steer angle to right side (CAN WAS) (P3195) ≤ 89	520241	2
	3428	Maximum steer angle, right	Vehicle Geometry			
	3244	WAS interface	Peripherals Config			
	3193	Automatically adjusted maximum steer angle to left side (CAN WAS)	CAN WAS Calibration Data			
	3195	Automatically adjusted maximum steer angle to right side (CAN WAS)	CAN WAS Calibration Data			
25	3086	Cylinder stroke volume	Hydraulic Config	If WAS interface (P3244) = ANALOG: Cylinder stroke volume (P3086) ≤ 10000 Or Automatically adjusted cylinder stroke volume (analogue WAS) (P3221) ≤ 10000	520232	2
	3221	Automatically adjusted cylinder stroke volume (analogue WAS)	Analog Sensor Calibration Data			
26	3086	Cylinder stroke volume	Hydraulic Config	If WAS interface (P3244) = CAN: Cylinder stroke volume (P3086) ≤ 10000 Or Automatically adjusted cylinder stroke volume (CAN WAS) (P3191) ≤ 10000	520232	2
	3191	Automatically adjusted cylinder stroke volume (CAN WAS)	CAN WAS Calibration Data			
27	3297	PVED-CLS source address	SEHS Protocol Data	A warning shall be displayed when same source address is set for Main and Safety controllers		

17.2 ERROR CODES

J1939-73 DM1, DM2 and DM3 diagnostic protocol is supported.

The list of DTC is divided in 7 sections:

1. **I/O signals:** This sections lists all failures related to analogue and digital inputs & outputs
2. **CAN Messages:** This Section lists all failures related to CAN messages
3. **Safety Functions:** This Section lists all failures caused by Safety functions and externally triggered safe state DTC's
4. **Diagnostic functions:** This section lists all failures detected by diagnostic functions
5. **Internal Hardware:** This section lists all failures found on the internal PCB in PVED-CLS
6. **Software:** This section lists all failures detected inside the software
7. **Monitoring:** This section lists all failures detected by crosscheck input signal and calculation results on SPI between main and Safety UC



Category	SPN	Signal Name	Failure mode	FMI	Severity	Possible root cause(s)
I/O Signals	520192	Analogue sensor connected to AD1	Short circuit to GND	4 - Voltage below normal or short-circuit to low source	Severe	1. Wire connected to AD1 lost connection (open circuit). 2. Wire connected to AD1 short circuit to GND.
			Short circuit to VCC	3 - Voltage above normal or short-circuit to high source	Severe	1. Wire connected to AD1 short circuit to a source higher than 4.9V.
			Too high deviation	25 - Signal crosscheck failed	Severe	1. Wheel angle sensors are not calibrated properly. 2. Sensor characteristics have changed. 3. If two physical separated sensors are used, one of them has lost the mechanical connection or has increased hysteresis 4. WAS crosscheck threshold parameter (P3375) does not match the wheel angle sensor mounting.
			Signal exceeded calibration limit	13 - Out of calibration	Severe	1. Wheel angle sensors are not calibrated properly. 2. Vehicle geometry has changed and it's now possible to steer the wheels further than the calibrated max points. 3. Mechanical link integrity lost
I/O Signals	520193	Analogue sensor connected to AD2	Short circuit to GND	4 - Voltage below normal or short-circuit to low source	Severe	1. Wire connected to AD2 lost connection (open circuit). 2. Wire connected to AD2 short circuit to GND.
			Short circuit to VCC	3 - Voltage above normal or short-circuit to high source	Severe	1. Wire connected to AD2 short circuit to a source higher than 4.9V.
I/O Signals	520195	Temperature Sensor	too low	1 - Data valid, but below normal operational range - Most severe level	Severe	1. Ambient Temperature is below -40 °C.
			too high	0 - Data valid, but above normal operational range - Most severe level	Severe	1. Ambient Temperature + self-heating of PVED-CLS (~-15 °C) is above 120 °C.
			too high average	16 - Data valid, but above normal operating range - Moderately severe level	Info	1. Average ambient temperature + self-heating of PVED-CLS (~-15 °C) is above 85 °C. This error code can only get active above 500hours of operation and has severity level INFO.
I/O Signals	627	Vbat	too high	3 - Voltage above normal or short-circuit to high source	Severe	1. Supply voltage is above 35.5V.
			too low	4 - Voltage below normal or short-circuit to low source	Info	1. Supply voltage is below 9V. This error code has severity level INFO
			Power on self-test failed due to too low battery supply	1 - Data valid, but below normal operational range - Most severe level	Severe	1. Supply voltage has been below 9V during Power-On-Self-Test for too long time
I/O Signals	520197	Sensor_+5V	too high	3 - Voltage above normal or short-circuit to high source	Severe	1. Sensor supply wire above 5.25V
			too low	4 - Voltage below normal or short-circuit to low source	Severe	1. Sensor supply wire below 4.75V 2. Sensor supply wire shortcut to GND 3. Too high load on sensor supply wire
I/O Signals	520198	Cut-Off supply	shortcut to GND	4 - Voltage below normal or short-circuit to low source	Severe	1. DOUT short-circuited to GND
			Shortcut to Vbat	3 - Voltage above normal or short-circuit to high source	Severe	1. DOUT short-circuited to Vbat
			Dutycycle differs from expected value	8 - Abnormal frequency or pulse width or period	Severe	1. Internal Failure
			Open circuit	5 - Current below normal or open circuit	Severe	1. No load connected to DOUT 2. Parameterized current levels (P3074 & P3076) do not match the connected load 3. DOUT short-circuited to Vbat
			Too high load	6 - Current above normal or grounded circuit	Severe	1. Load connected to DOUT is too high >2.5A 2. DOUT short-circuited to GND
520199 SASAIID sensor	CAN messages	CAN messages	never received (boot-up timeout)	22 - Message missing	Severe	1. SASAIID Not powered 2. SASAIID CAN Bus not connected 3. Incorrect parameter setting of SASAIID source address or PGN
			message lost (timeout)	9 - Abnormal update rate	Severe	1. SASA lost CAN bus or power connection
			invalid CRC or message sequence	19 - Received network data in error	Severe	1. CAN bus disturbance
			invalid velocity value	2 - Data erratic, intermittent or incorrect	Severe	1. SASA data out of range
			invalid position value	2 - Data erratic, intermittent or incorrect	Severe	1. SASA data out of range
			Error code signal displays active error	2 - Data erratic, intermittent or incorrect	Severe	1. SASAIID is sending error code - See communication protocol
CAN messages	520200	Vehicle Speed sensor	never received (boot-up timeout)	22 - Message missing	Severe	1. Vehicle speed sensor not powered 2. Vehicle speed sensor CAN Bus not connected 3. Incorrect parameter setting of VSP source address or PGN
			message lost (timeout)	9 - Abnormal update rate	Severe	1. Vehicle speed sensor lost CAN bus or power connection 2. Wrong message timing
			invalid CRC or message sequence	19 - Received network data in error	Severe	1. CAN bus disturbance 2. Incorrect Vehicle speed sensor message implementation
			invalid speed value	2 - Data erratic, intermittent or incorrect	Severe	1. Vehicle speed sensor data out of range
CAN messages	520201	MMI	never received (boot-up timeout)	22 - Message missing	Severe	1. MMI Not powered 2. MMI CAN Bus not connected 3. Incorrect parameter setting of MMI source address or PGN
			message lost (timeout)	9 - Abnormal update rate	Severe	1. MMI lost CAN bus or power connection 2. Wrong message timing
			invalid CRC or message sequence	19 - Received network data in error	Severe	1. CAN bus disturbance 2. Incorrect MMI message implementation
			invalid program	2 - Data erratic, intermittent or incorrect	Severe	1. MMI data out of range
			invalid off-road flag value	2 - Data erratic, intermittent or incorrect	Severe	1. MMI data out of range
invalid enable/disable command	2 - Data erratic, intermittent or incorrect	Severe	1. MMI data out of range			



Category	SPN	Signal Name	Failure mode	FMI	Severity	Possible root cause(s)
CAN messages	520202	Auxiliary steering device	never received (boot-up timeout)	22 - Message missing	Severe	1. AUX Not powered 2. AUX CAN Bus not connected 3. Incorrect parameter setting of AUX source address or PGN
			message lost (timeout)	9 - Abnormal update rate	Severe	1. AUX lost CAN bus or power connection 2. Wrong message timing
			invalid CRC or message sequence	19 - Received network data in error	Severe	1. CAN bus disturbance 2. Incorrect AUX message implementation
			Invalid flag value	2 - Data erratic, intermittent or incorrect	Severe	1. AUX data out of range
			invalid set-point	2 - Data erratic, intermittent or incorrect	Severe	1. AUX data out of range
CAN messages	520228	WAS CAN sensor	never received (boot-up timeout)	22 - Message missing	Severe	1. WAS Not powered 2. WAS CAN Bus not connected 3. Incorrect parameter setting of WAS source address or PGN
			message lost (timeout)	9 - Abnormal update rate	Severe	1. WAS lost CAN bus or power connection 2. Wrong message timing
			invalid CRC or message sequence	19 - Received network data in error	Severe	1. CAN bus disturbance 2. Incorrect WAS message implementation
			invalid position value	2 - Data erratic, intermittent or incorrect	Severe	1. WAS data out of range
			Signal exceeded calibration limit	13 - Out of calibration	Severe	1. Wheel angle sensors are not calibrated properly. 2. Vehicle geometry has changed and it is now possible to steer the wheels further than the calibrated max points. 3. Mechanical link integrity lost
Safety Functions	520203	Vehicle speed triggered EH-steering shut-off (Safety function 3)	Vehicle speed too high	31 - Condition exists	Severe	1. Vehicle speed is higher than the specified threshold specified by P3253
Safety Functions	520204	EH-main spool monitoring	EH spool position greater than set-point	7 - Mechanical system not responding or out of adjustment	Severe	1. EH-Spool out of control
			EH spool moved without steering input	23 - Unintended Steering	Severe	1. SASA disconnected from OSPCX in EHPS system
			Not in neutral at startup	28 - Not in neutral at Power-up	Severe	1. EH-Spool not in neutral at startup
Safety Functions	520205	Fault Detection Algorithm Monitoring	Unintended steering	23 - Unintended Steering	Severe	1. Improper sensor parameter setup 2. Chock valves have been open 3. Wheel angle sensor detached 4. SASAID sensor detached from steering column 5. Improper calibration of wheel angles 6. Change in spool calibration values
Safety Functions	520206	Safe ON-Road Monitoring	Switch stuck closed	30 - Stuck Closed	Severe	1. Road switch relay failure (relay is not able to disconnect load)
			Switch state undefined	2 - Data erratic, intermittent or incorrect	Severe	1. AD3 Road switch signal in undefined range
			Switch state missing	22 - Message missing	Severe	1. AD3 Road switch signal not able to stabilize within valid range during initialization
Safety Functions	520207	Road switch resistance monitoring	Switch state crosscheck failed	25 - Signal crosscheck failed	Severe	If P3072 = 255: 1. Internal failure If P3072 = 0 & P3242 = 255: 1. Mismatch in Road switch states between DOUT resistance and AD3 voltage signal
			Switch state undefined	2 - Data erratic, intermittent or incorrect	Severe	1. DOUT Resistance in invalid range
			Switch state missing	22 - Message missing	Severe	1. DOUT Resistance not able to stabilize within valid range during initialization
Safety Functions	520208	Demanded safe state	Switch state crosscheck failed	25 - Signal crosscheck failed	Severe	1. Mismatch in Road switch states between DOUT resistance and AD3 voltage signal
			externally triggered safe state	31 - Condition exists	Severe	1. Controller forced to safe state by peer controller via SPI. This happens for example when one of the controllers detects a failure, which the other controller is not capable of detecting
			unable to supply pilot flow to PVED	30 - Stuck Closed	Severe	1. No/insufficient Pump pressure
Diagnostic functions	520210	Cut-off solenoid	unable to cut pilot flow to PVED	29 - Stuck Open	Severe	1. Internal hydraulic failure in OSPE/EHi
			Synchronization failed	19 - Received network data in error	Severe	Internal failure
			Self-test failed	12 - Bad intelligent device or component	Severe	Internal failure
Diagnostic functions	299023	Coils Supply Switch	Safety switch state not in sync with operation	2 - Data erratic, intermittent or incorrect	Severe	Internal failure
			Synchronization failed	19 - Received network data in error	Severe	Internal failure
			Self-test failed	12 - Bad intelligent device or component	Severe	Internal failure
Diagnostic functions	520211	Overvoltage supervisor	Synchronization failed	19 - Received network data in error	Severe	Internal failure
			Self-test failed	12 - Bad intelligent device or component	Severe	Internal failure
Internal Hardware	520582	+5V	+5V signal out of range	2 - Data erratic, intermittent or incorrect	Severe	Internal failure
Internal Hardware	298967	CAN bus	CAN bus off and recovered	19 - Received network data in error	Severe	1. CAN bus disturbance 2. No/insufficient termination on the CAN bus network 3. Shortcut or wire breakage on CAN bus wire
			Address arbitration lost	11 - Unknown root-cause	Severe	1. Address conflict on the CAN bus
			Internal CAN Rx buffer overflow	12 - Bad intelligent device or component	Severe	2. Excessive number of messages intended for PVED CLS
			Internal CAN Tx buffer overflow for CAN priority 3 (safety related messages)	0 - Data valid, but above normal operational range - Most severe level	Severe	3. Excessive number of Priority 3 messages



Category	SPN	Signal Name	Failure mode	FMI	Severity	Possible root cause(s)
			Internal CAN Tx buffer overflow for CAN priority 6 (status messages)	15 - Data valid, but above normal operating range - Least severe level	INFO	4. Excessive number of Priority 6 messages
Internal Hardware	299029	EEPROM	Verified write fails on EEPROM cell	12 - Bad intelligent device or component	Severe	Internal failure
Internal Hardware	520212	LVDT sinus signal	LVDT sinus frequency out of range	8 - Abnormal frequency or pulse width or period	Severe	Internal failure
Internal Hardware	520585	Vref generation	Vref signal out of range	2 - Data erratic, intermittent or incorrect	Severe	Internal failure
Internal Hardware	520586	GND level	GND level above upper limit	3 - Voltage above normal or short-circuit to high source	Severe	Internal failure
Internal Hardware	520588	LVDT demod A	LVDT demo A signal out of range	2 - Data erratic, intermittent or incorrect	Severe	Internal failure
Internal Hardware	520589	LVDT demod B	LVDT demo B signal out of range	2 - Data erratic, intermittent or incorrect	Severe	Internal failure
Software	520229	Soft error	Soft error detected	31 - Condition exists	Severe	Internal failure
Software	520213	SPI Communication	Connection loss	11 - Unknown root-cause	Severe	Internal failure
			SPI message queue full	2 - Data erratic, intermittent or incorrect	Severe	Internal failure
Software	1557	RAM test	RAM-code test fails	12 - Bad intelligent device or component	Severe	Internal failure
Software	520579	EEPROM VPS data	Parameter value out of range/Incorrect configuration of EEPROM data	2 - Data erratic, intermittent or incorrect	Severe	1. Parameter setting out of range 2. Incorrect sector CRC
			Approval CRC failure	14 - Special instructions	Severe	1. Incorrect Approval CRC
Software	520232	EEPROM Hydraulic config	Parameter value out of range/Incorrect configuration of EEPROM data	2 - Data erratic, intermittent or incorrect	Severe	1. Parameter setting out of range 2. Incorrect sector CRC
			Approval CRC failure	14 - Special instructions	Severe	1. Incorrect Approval CRC
Software	520233	EEPROM SEHS FDA	Parameter value out of range/Incorrect configuration of EEPROM data	2 - Data erratic, intermittent or incorrect	Severe	1. Parameter setting out of range 2. Incorrect sector CRC
			Approval CRC failure	14 - Special instructions	Severe	1. Incorrect Approval CRC
Software	520234	EEPROM Valve calibration data	Parameter value out of range/Incorrect configuration of EEPROM data	2 - Data erratic, intermittent or incorrect	Severe	1. Parameter setting out of range 2. Incorrect sector CRC
			Approval CRC failure	14 - Special instructions	Severe	1. Incorrect Approval CRC
Software	520235	EEPROM CAN WAS Calibration data	Parameter value out of range/Incorrect configuration of EEPROM data	2 - Data erratic, intermittent or incorrect	Severe	1. Parameter setting out of range 2. Illegal parameter combinations – see section 17.4.4 3. Incorrect sector CRC
			Approval CRC failure	14 - Special instructions	Severe	1. Incorrect Approval CRC
Software	520236	EEPROM Analogue Sensor Calibration data	Parameter value out of range/Incorrect configuration of EEPROM data	2 - Data erratic, intermittent or incorrect	Severe	1. Parameter setting out of range 2. Illegal parameter combinations – see section 17.4.5 3. Incorrect sector CRC
			Approval CRC failure	14 - Special instructions	Severe	1. Incorrect Approval CRC
Software	520237	EEPROM Peripherals config	Parameter value out of range/Incorrect configuration of EEPROM data	2 - Data erratic, intermittent or incorrect	Severe	1. Parameter setting out of range 2. Illegal parameter combinations – see section 17.4.6 3. Incorrect sector CRC
			Approval CRC failure	14 - Special instructions	Severe	1. Incorrect Approval CRC
Software	520238	EEPROM SEHS Protocol data	Parameter value out of range/Incorrect configuration of EEPROM data	2 - Data erratic, intermittent or incorrect	Severe	1. Parameter setting out of range 2. Incorrect sector CRC
			Approval CRC failure	14 - Special instructions	Severe	1. Incorrect Approval CRC
Software	520239	EEPROM Internal monitoring	Parameter value out of range/Incorrect configuration of EEPROM data	2 - Data erratic, intermittent or incorrect	Severe	1. Parameter setting out of range 2. Incorrect sector CRC
			Approval CRC failure	14 - Special instructions	Severe	1. Incorrect Approval CRC
Software	520241	EEPROM Vehicle geometry	Parameter value out of range/Incorrect configuration of EEPROM data	2 - Data erratic, intermittent or incorrect	Severe	1. Parameter setting out of range 2. Incorrect sector CRC
			Approval CRC failure	14 - Special instructions	Severe	1. Incorrect Approval CRC
Software	520242	EEPROM GPS config	Parameter value out of range/Incorrect configuration of EEPROM data	2 - Data erratic, intermittent or incorrect	Severe	1. Parameter setting out of range 2. Illegal parameter combinations – see section 12 3. Incorrect sector CRC
			Approval CRC failure	14 - Special instructions	Severe	1. Incorrect Approval CRC
Software	520243	EEPROM STW config	Parameter value out of range/Incorrect configuration of EEPROM data	2 - Data erratic, intermittent or incorrect	Severe	1. Parameter setting out of range 2. Illegal parameter combinations – see section 10 3. Incorrect sector CRC
			Approval CRC failure	14 - Special instructions	Severe	1. Incorrect Approval CRC
Software	520244	EEPROM AUX config	Parameter value out of range/Incorrect configuration of EEPROM data	2 - Data erratic, intermittent or incorrect	Severe	1. Parameter setting out of range 2. Illegal parameter combinations – see section 11 3. Incorrect sector CRC
			Approval CRC failure	14 - Special instructions	Severe	1. Incorrect Approval CRC



Category	SPN	Signal Name	Failure mode	FMI	Severity	Possible root cause(s)
Software	520245	EEPROM Auto-Calibration config sector	Parameter value out of range/Incorrect configuration of EEPROM data	2 - Data erratic, intermittent or incorrect	Severe	1. Parameter setting out of range 2. Incorrect sector CRC
			Approval CRC failure	14 - Special instructions	Severe	1. Incorrect Approval CRC
Software	520246	Invalid sensor configuration	Invalid sensor configuration	31 - Condition exists	Severe	If parameter settings are not done as per section 6.1.1
Software	299005	Software Initialization	Fault in software configuration or initialization process	11 - Unknown root-cause	Severe	Internal failure
Software	299004	Division by zero	Division by zero	11 - Unknown root-cause	Severe	Internal failure
Software	628	Flash test	Flash test failure	12 - Bad intelligent device or component	Severe	Internal failure
Software	299002	Variable truncation	Variable truncation	11 - Unknown root-cause	Severe	Internal failure
Software	299001	I2C communication	I2C communication failure	12 - Bad intelligent device or component	Severe	Internal failure
Software	520592	Too many errors	Too many errors to handle	0 - Data valid, but above normal operational range - Most severe level	Severe	1. If more than 5 errors happen at the same time, this error code will be shown by PVED-CLS
Software	298968	Interpolation	Interpolation overflow or underflow or incorrect data	11 - Unknown root-cause	Severe	Internal failure
Software	520577	SVC Parameters	Invalid PWM calibration values	2 - Data erratic, intermittent or incorrect	Severe	Internal failure
Software	298966	Program sequence monitoring	Program sequence monitoring failure	11 - Unknown root-cause	Severe	Internal failure
Software	298965	PSM task	PSM task record buffer full or slow PSM data processing	11 - Unknown root-cause	Severe	Internal failure
Software	520583	LVDT calculation	Denominator used in LVDT calculation out of range	2 - Data erratic, intermittent or incorrect	Severe	Internal failure
Software	1563	Software Mismatch	Software does not match peer controller	31 - Condition exists	Severe	PVED-CLS main controller contains a different software version than the PVED-CLS safety controller
Software	1562	Incompatible Bootloader	Bootloader is not compatible to application	31 - Condition exists	Severe	PVED-CLS main and/or safety controller contains a bootloader version not compatible to the application software
Software	520240	PVED-CLS Spare part	This DTC informs that this unit is running a spare part software (Info level DTC)	31 - Condition exists	Info	This DTC is shown by spare parts
Monitoring	520214	Flow command crosscheck	crosscheck failure	25 - Signal crosscheck failed	Severe	1. Flow command calculation by PVED-CLS Main controller and PVED-CLS Safety controller. This can happen if fx. Gain parameters are not equal in Main and Safety controller.
			loops to look back in Flow CMD buffer exceeded buffer length	2 - Data erratic, intermittent or incorrect	Severe	Internal failure
Monitoring	520225	EH-Mainspool Position crosscheck	crosscheck failure	25 - Signal crosscheck failed	Severe	Internal failure
Monitoring	520215	Wheel angle crosscheck	cross-check failure	25 - Signal crosscheck failed	Severe	If P3244 is set to 0: Internal failure If P3244 is set to 255: 1. CAN Wheel angle sensors are not calibrated properly. 2. Sensor characteristics have changed. 3. If two physical separated sensors are used, one of them has lost the mechanical connection or has increased hysteresis 4. WAS crosscheck threshold parameter (P3352) does not match the wheel angle sensor mounting. 5. CAN Wheel angle sensor transmit rate of primary and redundant signal deviate too much from each other
Monitoring	520216	Vehicle Speed sensor speed crosscheck	cross-check failure	25 - Signal crosscheck failed	Severe	1. Vehicle speed signal deviation too high between primary and redundant signal 2. Transmit rate of primary and redundant signal deviate too much from each other 3. P3363 & P3364 settings does not fit to the vehicle speed sensor
Monitoring	520217	STW sensor Position crosscheck (SASA)	cross-check failure	25 - Signal crosscheck failed	Severe	SASA Failure
Monitoring	520227	STW sensor Speed crosscheck (SASA)	cross-check failure	25 - Signal crosscheck failed	Severe	SASA Failure
Monitoring	520218	Auxiliary steering device Steering angle crosscheck	cross-check failure	25 - Signal crosscheck failed	Severe	1. AUX mini wheel steering angle deviation too high between primary and redundant signal 2. Transmit rate of primary and redundant signal deviate too much from each other 3. P3371 & P3372 settings does not fit to the AUX mini wheel device
Monitoring	520230	Auxiliary steering device Steering angle velocity crosscheck	cross-check failure	25 - Signal crosscheck failed	Severe	1. AUX mini wheel steering angle velocity deviation too high between primary and redundant signal 2. Transmit rate of primary and redundant signal deviate too much from each other 3. P3365 & P3366 settings does not fit to the AUX mini wheel device
Monitoring	520231	Auxiliary steering device Joystick position crosscheck	cross-check failure	25 - Signal crosscheck failed	Severe	1. AUX Joystick flow request deviation too high between primary and redundant signal 2. Transmit rate of primary and redundant signal deviate too much from each other 3. P3368 & P3369 settings does not fit to the AUX joystick
Monitoring	520247	Auxiliary steering device Joystick trim value crosscheck	cross-check failure	25 - Signal crosscheck failed	Severe	1. AUX Joystick trim signal deviation too high between primary and redundant signal 2. Transmit rate of primary and redundant signal deviate too much from each other 3. P3388 & P3389 settings does not fit to the AUX joystick
Monitoring	520248	Auxiliary steering device Joystick enable signal crosscheck	cross-check failure	25 - Signal crosscheck failed	Severe	1. Transmit rate of primary and redundant signal deviate too much from each other 2. P3387 setting does not fit to the AUX joystick
Monitoring	520219	Executed steering device/program crosscheck (application state)	cross-check failure	25 - Signal crosscheck failed	Severe	1. P3237, P3238, P3239, P3241, P3250 or P3251 are set to different values in PVED-CLS Main and Safety controller



Category	SPN	Signal Name	Failure mode	FMI	Severity	Possible root cause(s)
Monitoring	520224	MMI flag crosscheck	cross-check failure	25 - Signal crosscheck failed	Severe	1. MMI signals do not match between primary and redundant signal 2. Transmit rate of primary and redundant signal deviate too much from each other 3. P3374 setting does not fit to the MMI device
Monitoring	520249	IMD status crosscheck	cross-check failure	25 - Signal crosscheck failed	Severe	4.

Table 62

Attention



If ‘EEPROM VPS data’ related failures are detected then the parameter configurations related to VPS data can only be acquired by directly contacting the Danfoss technical support team.



17.3 FMI LIST

In PVED-CLS the standard FMI from J1939-73 Appendix A page 130 are used as much as possible. However, in some cases some of the reserved area FMI's are redefined to suit the need.

The List of FMI's used in PVED-CLS is found below:

Index	Failure mode
0	0 - Data valid, but above normal operational range - Most severe level
1	1 - Data valid, but below normal operational range - Most severe level
2	2 - Data erratic, intermittent or incorrect
3	3 - Voltage above normal or short-circuit to high source
4	4 - Voltage below normal or short-circuit to low source
5	5 - Current below normal or open circuit
6	6 - Current above normal or grounded circuit
7	7 - Mechanical system not responding or out of adjustment
8	8 - Abnormal frequency or pulse width or period
9	9 - Abnormal update rate
10	10 - Abnormal rate of change
11	11 - Unknown root-cause
12	12 - Bad intelligent device or component
13	13 - Out of calibration
14	14 - Special instructions
15	15 - Data valid, but above normal operating range - Least severe level
16	16 - Data valid, but above normal operating range - Moderately severe level
17	17 - Data valid, but below normal operating range - Least severe level
18	18 - Data valid, but below normal operating range - Moderately severe level
19	19 - Received network data in error
20	20 - Data drifted high
21	21 - Data drifted low
22	22 - Message missing
23	23 - Unintended Steering
24	24 - Reserved
25	25 - Signal crosscheck failed
26	26 - No steering
27	27 - Unable to return to neutral
28	28 - Not in neutral at Power-up
29	29 - Stuck Open
30	30 - Stuck Closed
31	31 - Condition exists

Table 63



17.4 PARAMETER LIST

17.4.1 Hydraulic config

Name	Address	Data type	Unit	Description of parameter	User	Range		Danfoss default value	Safety critical parameters 'S'
						Min.	Max.		
Cut-off valve present	P3072	U8	-	Cut-off Valve Present/Not Present Valid Values: 0 (NOT PRESENT); 255 (PRESENT)	OEM	0	255	255	S
Cut-off valve control mode	P3073	U8	-	Cut-off Valve control mode Close loop Control or ON-OFF control Valid Values: 0 (ON-OFF control); 255 (Closed loop control)	OEM	0	255	255	S
Cut-off valve CL pull current	P3074	U16	mAmp	Current required to activate Cut-off valve	OEM	100	2000	1100	S
Cut-off valve CL hold current	P3076	U16	mAmp	Current required to maintain to Cut-off in ON state	OEM	100	2000	500	S
Cut-off valve monitoring POST timeout	P3078	U16	x10mSec	Cut Off Valve Activation Timeout for COV Monitoring feature while entering Off Road state. INFO: Setting this parameter to 0 will bypass off-road safety check	OEM	0	1000	900	S
Invert flow direction	P3080	U8	-	Changes the direction of the requested flow Valid Values: 0 (NO, DEFAULT OSPE/EHi); 255 (YES, DEFAULT EHPS)	OEM	0	255	0	S
Valve type	P3081	U8	-	Valve type on which the PVED-CLS is mounted Valid Values: 0 (OSPE, EHi-E); 1 (EHPS); 2 (EHi-H)	OEM	0	2	0	S
Turns lock-to-lock EHPS	P3082	U16	-	Number of steering wheel turns lock-to-lock, without PVED-CLS activated (hence pure hydraulic). Lock-to-lock is dependent on: <ul style="list-style-type: none"> OSP displacement EH-spool and pilot flow Standby pressure (spring force) Cylinder volume Contact your local technical support at Danfoss Power Solutions for specific calculation, or simply do the measurement/exercise on the vehicle Resolution: 0.01 turns	OEM	100	1000	450	S
OSP displacement	P3084	U16	Ccm	OSP displacement, number of cubic centimeters per revolution Note: When the PVED-CLS is mounted on an EHPS this parameter must be set equal to 0!	OEM	0	1200	120	S
Cylinder stroke volume	P3086	U16	Ccm	Cylinder stroke volume. Acceptable values: 100-10000. Note: Writing values >10000 will force to use automatic adjusted cylinder stroke volume-value on WAS calibration	OEM	100	65535	500	S
Valve capacity	P3088	U8	Lpm	EH valve size, defined in liters per minute	OEM	5	120	20	S
LVDT offset compensation Enable/Disable	P3089	U8	-	LVDT Offset compensation Enable/Disable Valid Values: 0 (DISABLE); 255 (ENABLE)	OEM	0	255	255	
Absolute spool neutral threshold range	P3090	U8	10 um (signed Dec)	Absolute value of Spool neutral threshold range	OEM	0	200	25	
Max spool pos left copy	P3091	S16	x10um	Spool left most position copied by spool auto-calibration before the internal calculation of the sector CRC	OEM	-1000	0	0	
Max spool pos right copy	P3093	S16	x10um	Spool right most position copied by spool auto-calibration before the internal calculation of the sector CRC	OEM	0	1000	0	
Offset dead-band OL copy	P3095	S16	x10um	Spool open loop dead-band offset copied by spool auto-calibration before the internal calculation of the sector CRC	OEM	0	150	0	
Cut-off valve PWM pre-load value	P3097	U8	%	Cut-off valve PWM pre-load value	OEM	0	100	100	
Safety checks IMD - Rise time limit	P3098	U8	x10mSec	Maximum rise time after switching ON cut-off valve for indicating EH-Spool is under control during safety check.	OEM	10	100	30	S
Safety checks IMD - Fall time limit	P3099	U8	x10mSec	Maximum fall time after switching OFF cut-off valve for indicating EH-Spool is under control during safety check.	OEM	10	100	25	S
Safety checks IMD - Pass criteria	P3100	U8	dec	P3100 specifies how many safety check cycles with successful EH-Spool control shall be executed before PVED-CLS passes the safety checks.	OEM	2	8	2	S
Safety checks IMD - Maximum fall time	P3101	U16	x10mSec	If the EH-Spool does not return to neutral within this timeout, the cut-off solenoid is concluded to be stuck open.	OEM	100	1000	100	

Table 64



17.4.2 SEHS FDA

Name	Address	Data type	Unit	Description of parameter	User	Range		Danfoss default value	Safety critical parameters 'S'
						Min.	Max.		
Fault Detection Algorithm - Steering wheel activation velocity threshold	P3122	U8	dRpm	Steering wheel angle velocity threshold used in the Fault Detection Algorithm to detect the steering wheel activation	OEM	0	150	5	S
Fault Detection Algorithm - min. wheel angle movement threshold	P3123	U8	IR	Minimum wheel angle difference necessary to observe in order to make the Fault Detection Algorithm assume that the wheels are moving. The difference is calculated between the current WA position and WA number of loops back. Number is defined by P3124.	OEM	0	200	50	S
Fault Detection Algorithm - wheel angle sensor delay	P3124	U8	x10mSec	Number of loops between samples that are being compared against P3123 for WA motion determination	OEM	1	20	1	S
Fault Detection Algorithm - Fault confidence counter decrease rate	P3125	U8	x10mSec	Rate at which the Fault Detection Algorithm confidence counter value decreases if an error is no longer observed	OEM	1	10	1	S
Fault Detection Algorithm - Fault confidence counter timeout	P3126	U16	x10mSec	Time period for which error shall be observed by FDA to report failure	OEM	0	2000	50	S
Fault Detection Algorithm - Spool in left position range offset	P3128	S16	x10u Meter	Distance from closed loop dead-band to check if spool in left side	OEM	-200	200	0	S
Fault Detection Algorithm - Spool in right position range offset	P3130	S16	x10u Meter	Distance from closed loop dead-band to check if spool in right side	OEM	-200	200	0	S
Fault Detection Algorithm - Safe state upon a failure detection	P3132	U8	-	<p>FDA safe state trigger Enable/Disable after failure detection. Valid Values: 0 (DISABLE); 255 (ENABLE)</p> <p>Warning</p>  <p>DISABLE should only be used when diagnosis of the wheel angle sensor and SASA failure modes are ensured by another monitoring function or when getting initial data for FDA tuning</p>	OEM	0	255	0	S
Fault Detection Algorithm - Backlash region	P3133	U8	dDeg	Backlash limit to use in the backlash filter in the FDA control algorithm exclusively Resolution: 1dDeg = 0.1Deg	OEM	0	200	5	S
Fault Detection Algorithm - Vehicle speed threshold for EHPS	P3134	U8	km/h	Will disable the FDA and spool monitoring if speed of the vehicle goes below this value. Should only be changed if EHPS/OSPE/EHi system is underpowered, hence the system does not have enough pressure to move the wheels (normally when vehicle is not moving)	OEM	0	10	0	S

Table 65



17.4.3 Valve Calibration

Name	Address	Data type	Unit	Description of parameter	User	Range		Danfoss default value	Safety critical parameters 'S'
						Min.	Max.		
Max spool position, left	P3162	S16	x10u Meter	Spool left most position	OEM, Dealer	-1000	-300	-420	
Max spool position, right	P3164	S16	x10u Meter	Spool right most position	OEM, Dealer	300	1000	420	
Closed loop dead-band edge, left	P3166	S16	x10u Meter	Spool closed loop dead-band edge, Left	OEM, Dealer	-300	0	-105	
Closed loop dead-band edge, right	P3168	S16	x10u Meter	Spool closed loop dead-band edge, Right	OEM, Dealer	0	300	105	
Open loop dead-band edge offset	P3170	S16	x10u Meter	Spool open loop dead-band offset	OEM, Dealer	0	150	25	

Table 66

17.4.4 CAN WAS Calibration Data

Name	Address	Data type	Unit	Description of parameter	User	Range		Danfoss default value	Safety critical parameters 'S'
						Min.	Max.		
WAS max left position (CAN)	P3185	U16	mVolts	Wheel angle sensor voltage output for leftmost position over CAN	OEM, Dealer	0	5000	500	
WAS max right position (CAN)	P3187	U16	mVolts	Wheel angle sensor voltage output for rightmost position over CAN	OEM, Dealer	0	5000	4500	
WAS neutral position (CAN)	P3189	U16	mVolts	Wheel angle sensor voltage output for neutral position over CAN	OEM, Dealer	0	5000	2500	
Automatically adjusted cylinder stroke volume (CAN WAS)	P3191	U16	ccm	Automatically adjusted cylinder stroke volume, for using CAN WAS, found during WAS auto-calibration	OEM, Dealer	100	65535	65535	
Automatically adjusted maximum steer angle to left side (CAN WAS)	P3193	U16	Deg	Automatically adjusted maximum steer angle to left side, for using CAN WAS, found during WAS auto-calibration	OEM, Dealer	0	65535	65535	
Automatically adjusted maximum steer angle to right side (CAN WAS)	P3195	U16	Deg	Automatically adjusted maximum steer angle to right side, for using CAN WAS, found during WAS auto-calibration	OEM, Dealer	0	65535	65535	

Table 67

Important

For CAN WAS calibration data sector, the following rules apply:
 P3185 < P3187 < P3189 OR P3185 > P3187 > P3189

17.4.5 Analog Sensor Calibration Data

Name	Address	Data type	Unit	Description of parameter	User	Range		Danfoss default value	Safety critical parameters 'S'
						Min.	Max.		
Primary analogue sensor max left position	P3205	U16	mVolts	Primary analogue sensor voltage output for leftmost position	OEM, Dealer	0	6000	500	
Primary analogue sensor max right position	P3207	U16	mVolts	Primary analogue sensor voltage output for rightmost position	OEM, Dealer	0	6000	4500	
Primary analogue sensor neutral position	P3209	U16	mVolts	Primary analogue sensor voltage output for neutral position	OEM, Dealer	0	6000	2500	
Redundant analogue sensor max left position	P3211	U16	mVolts	Redundant analogue sensor voltage output for leftmost position	OEM, Dealer	0	6000	500	
Redundant analogue sensor max right position	P3213	U16	mVolts	Redundant analogue sensor voltage output for rightmost position	OEM, Dealer	0	6000	4500	
Redundant analogue sensor neutral position	P3215	U16	mVolts	Redundant analogue sensor voltage output for neutral position	OEM, Dealer	0	6000	2500	
5V sensor supply for primary analogue sensor during calibration	P3217	U16	mVolts	Measured Supply voltage during calibration of the primary analogue sensor	OEM, Dealer	4650	5350	5000	
5V sensor supply for redundant analogue sensor during calibration	P3219	U16	mVolts	Measured Supply voltage during calibration of the redundant analogue sensor	OEM, Dealer	4650	5350	5000	
Automatically adjusted cylinder stroke volume (analogue WAS)	P3221	U16	ccm	Automatically adjusted cylinder stroke volume, for using analogue WAS, found during WAS auto-calibration	OEM, Dealer	100	65535	65535	
Automatically adjusted maximum steer angle to left side (analogue WAS)	P3223	U16	Deg	Automatically adjusted maximum steer angle to left side, for using analogue WAS, found during WAS auto-calibration	OEM, Dealer	0	65535	65535	
Automatically adjusted maximum steer angle to right side (analogue WAS)	P3225	U16	Deg	Automatically adjusted maximum steer angle to right side, for using analogue WAS, found during WAS auto-calibration	OEM, Dealer	0	65535	65535	

Table 68

Important

For analog sensor calibration data sector, the following rules apply:

$P3205 < P3207 < P3209$ OR $P3205 > P3207 > P3209$

AND if P3245 is set to 255 (redundant WAS is present)

$P3211 < P3213 < P3215$ OR $P3211 > P3213 > P3215$



17.4.6 Peripherals Config

Name	Address	Data type	Unit	Description of parameter	User	Range		Danfoss default value	Safety critical parameters 'S'
						Min.	Max.		
GPS present	P3237	U8	-	Auto-guidance controller present/Not Present Valid Values: 0 (NOT PRESENT); 255 (PRESENT)	OEM	0	255	255	
GPS2 present	P3238	U8	-	A second auto-guidance controller present/Not Present Valid Values: 0 (NOT PRESENT); 255 (PRESENT)	OEM	0	255	255	
AUX present	P3239	U8	-	AUX device Present/Not Present Valid Values: 0 (NOT PRESENT); 255 (PRESENT)	OEM	0	255	0	
AUX type	P3240	U8	-	Aux device is mini steering wheel or Joystick Valid Values: 0 (Open Loop Joystick); 1 (Closed Loop Joystick); 2 (mini steering wheel); 3 (Analogue Joystick);20 (Elobau joystick)	OEM	0	20	2	
Road switch present (connected to AD3)	P3241	U8	-	Specifies whether the road switch is or is not present, i.e. connected to the analogue input AD3 Valid Values: 0 (NOT PRESENT); 255 (PRESENT)	OEM	0	255	255	S
Road switch resistance check	P3242	U8	-	Road Switch Resistance check Enable/Disable Valid Values: 0 (DISABLE); 255 (ENABLE)	OEM	0	255	0	S
Max COV connection test current	P3243	U8	mAmp	The max. current allowed to be observed during the cut-off solenoid valve connection test.	OEM	10	255	100	S
WAS interface	P3244	U8	-	Wheel Angle Sensor Interface Type Valid Values: 0 (ANALOGUE); 1 (CAN); 2 (NONE)	OEM	0	2	0	
Redundant WAS present	P3245	U8	-	Redundant Wheel Angle Sensor Present/Not Present Valid Values: 0 (NOT PRESENT); 255 (PRESENT)	OEM	0	255	255	S
Voltage compensation for Primary analogue sensor	P3246	U8	-	Supply voltage compensation Enable/Disable for processing primary Analogue sensor signal Valid Values: 0 (DISABLE); 255 (ENABLE)	OEM	0	255	255	
Voltage compensation for Redundant analogue sensor	P3247	U8	-	Supply voltage compensation Enable/Disable for processing redundant analogue sensor signal Valid Values: 0 (DISABLE); 255 (ENABLE)	OEM	0	255	255	
Generation of 5V sensor supply voltage (Deutsch connector pin 11)	P3248	U8	-	Sensor Supply Test. Disable/enable the internal 5V supply on the PVED-CLS' pin 11. Valid Values: 0 (Enable); 1 (Disable) Note: Should be kept at Enable (P3248 set to 0) all time	OEM	0	1	0	
AD low pass filter cut-off frequency	P3249	U8	dHz	5V sensor, AD1 and AD2 filter cut-off frequency Resolution: 1 dHz = 0.1 Hz	OEM	5	200	100	
Max vehicle speed for engaging auto-guidance or AUX steering device	P3250	U8	km/h	Max vehicle speed at which a lower priority steering device can be engaged	OEM	0	100	15	S
Max vehicle speed for steering program changes	P3251	U8	km/h	Max vehicle speed at which a steering program for the selected device can be changed	OEM	0	100	15	S
Lower vehicle speed auto-guidance suspend threshold	P3252	U8	x10m/h	Minimum vehicle speed below which spool movement is disabled when auto-guidance steering is engaged. Resolution: 1 x10m/h = 10 meter pr. hour	OEM	0	200	50	S
Safe state vehicle speed threshold	P3253	U8	km/h	The vehicle speed at which the PVED-CLS shall enter the safe state	OEM	5	100	25	S
EH-Steering disengage method	P3254	U8	-	EH-Steering disengage method Valid values: 0 (SASA); 1 (IMD: Internally Monitored Disengage)	OEM	0	1	0	

Table 69

Important

For the Peripherals sector some rules apply to P3072, P3241 & P3242. See list of rules in Table 11.



17.4.7 SEHS Protocol Data

Name	Address	Data type	Unit	Description of parameter	User	Range		Danfoss default value	Safety critical parameters 'S'
						Min.	Max.		
SASA message monitoring - Max time difference between two messages	P3287	U8	x10msec	CAN message monitoring - SASA message monitoring - max time difference between two messages	OEM	5	255	8	S
Vehicle speed sensor message monitoring - Max time difference between two messages	P3288	U8	x10msec	CAN message monitoring - Vehicle speed sensor message monitoring - max time difference between two messages	OEM	10	255	15	S
Auto-guidance message monitoring - Max time difference between two messages	P3289	U8	x10msec	CAN message monitoring - Auto-guidance message monitoring - max time difference between two messages	OEM	10	255	22	S
Wheel angle sensor message monitoring - Max time difference between two messages	P3290	U8	x10mSec	CAN message monitoring - Wheel Angle Sensor message monitoring - Max time difference between two messages	OEM	2	255	8	S
AUX message monitoring - Max time difference between two messages	P3291	U8	x10mSec	CAN message monitoring - AUX message monitoring - Max time difference between two messages	OEM	5	255	8	S
GPS source address	P3292	U8	-	J1939 Source Address of the auto-guidance controller	OEM	0	253	28	
GPS2 source address	P3293	U8	-	J1939 Source Address of the second auto-guidance controller	OEM	0	253	29	
Vehicle speed sensor source address	P3294	U8	-	J1939 Source Address of the vehicle speed sensor	OEM	0	253	251	
MMI source address	P3295	U8	-	J1939 Source Address of the MMI	OEM	0	253	252	
SASA sensor source address	P3296	U8	-	J1939 Source Address of the SASAIID sensor	OEM	0	253	77	
PVED-CLS source address	P3297	U8	-	J1939 Source Address of the PVED (avoid using 127 and 241)	OEM	0	253	19, 90*	
Wheel angle sensor source address	P3298	U8	-	J1939 Source Address of the wheel angle sensor	OEM	0	253	250	
AUX device (mini steering wheel) source address	P3299	U8	-	J1939 Source Address of the AUX device (mini steering wheel)	OEM	0	253	79	
AUX device (joystick) source address	P3300	U8	-	J1939 Source Address of the AUX device (joystick)	OEM	0	253	78	
Transmission rate - Operation Status Messages	P3301	U8	x10mSec	Default transmission rate of the Operation Status Messages	OEM	1	254	10	
Transmission rate - Status message 1	P3302	U8	x10mSec	Default transmission rate of the Status Message 1	OEM	0	255	0	
Transmission rate - Status message 2	P3303	U8	x10mSec	Default transmission rate of the Status Message 2	OEM	0	255	0	
Transmission rate - Status message 3	P3304	U8	x10mSec	Default transmission rate of the Status Message 3	OEM	0	255	0	
Transmission rate - Status message 4	P3305	U8	x10mSec	Default transmission rate of the Status Message 4	OEM	0	255	0	
Transmission rate - Status message 5	P3306	U8	x10mSec	Default transmission rate of the Status Message 5	OEM	0	255	0	
Transmission rate - Status message 6	P3307	U8	x10mSec	Default transmission 6 rate of the Status Message 6	OEM	0	255	0	
Transmission rate - Steering feedback message	P3308	U8	x10mSec	Transmission rate of steering feedback message	OEM	0	255	5	
Transmission rate - Guidance machine status message	P3309	U8	x10mSec	Transmission rate of Guidance Machine Status message	OEM	1	10	10	
PVED-CLS address claim - Function instance	P3310	U8	-	Function instance field in Address claim message	OEM	0	32	0	
PGN offset to operation status messages	P3311	U8	-	PGN offset to Operation Status messages	OEM	0	255	32	
PGN offset to status message 1	P3312	U8	-	PGN offset to Status message 1	OEM	0	255	33	
PGN offset to status message 2	P3313	U8	-	PGN offset to Status message 2	OEM	0	255	34	



PGN offset to status message 3	P3314	U8	-	PGN offset to Status message 3	OEM	0	255	35	
PGN offset to status message 4	P3315	U8	-	PGN offset to Status message 4	OEM	0	255	36	
PGN offset to status message 5	P3316	U8	-	PGN offset to Status message 5	OEM	0	255	37	
PGN offset to status message 6	P3317	U8	-	PGN offset to Status message 6	OEM	0	255	38	
PGN offset to vehicle speed sensor message	P3318	U8	-	PGN offset to Vehicle speed message	OEM	0	255	64,65*	
PGN offset to steering wheel sensor messages	P3319	U8	-	PGN offset to SASA (steering wheel sensor) messages	OEM	0	255	16,17*	
PGN offset to wheel angle sensor messages	P3320	U8	-	PGN offset to Wheel Angle Sensor messages	OEM	0	255	18,19*	
PGN offset to AUX mini-steering wheel messages	P3321	U8	-	PGN offset to AUX device (mini steering wheel) messages	OEM	0	255	20,21*	
PGN offset to AUX joystick messages	P3322	U8	-	PGN offset to AUX device (joystick) messages	OEM	0	255	22,23*	
PGN offset to steering feedback message	P3323	U8	-	PGN offset to Steering Feedback Message	OEM	0	255	24	
PGN type for MMI message	P3324	U8	-	PGN type for MMI message: Proprietary A = 0; Proprietary B = 255	OEM	0	255	0	
PGN offset to MMI message	P3325	U8	-	PGN offset to MMI message , when using Proprietary B message format	OEM	0	255	66, 67*	
GMS message layout as per ISO11783	P3326	U8	-	Valid Values: 0 (Layout according to ISO11783-7:2009); 255 (Layout according to ISO11783-7:2015) See PVED-CLS communication protocol for clarification	OEM	0	255	0	
Transmission rate - Status message 7	P3327	U8	x10mSec	Default transmission rate of the Status Message 7	OEM	0	255	0	
PGN offset to Status message 7	P3328	U8	-	PGN offset to Status message 7	OEM	0	255	39	
PGN for AUX Elobau joystick	P3329	U16	-	PGN for Aux Elobau Joystick- PGN values for BJM1,BJM2,EJM1 and EJM2 are 64982,64984,64983 and 64985 respectively.	OEM	0	65535	64982	
Transmission rate - Status message 8	P3331	U8	x10mSec	Default transmission rate of the Status Message 8	OEM	0	255	0	
PGN offset to Status message 8	P3332	U8	-	PGN offset to Status message 8	OEM	0	255	40	
Priority of Operational Status message	P3333	U8	-	Priority of Operational Status message Valid Values: 0 (CAN message priority 6) 255 ((CAN message priority 3)	OEM	0	255	0	

Table 70

*The value should not be the same in the Main- and Safety-controller!



17.4.8 Internal Monitoring

Name	Address	Data type	Unit	Description of parameter	User	Range		Danfoss default value	Safety critical parameters 'S'
						Min.	Max.		
Channel cross-check monitoring - Max wheel angle divergence time	P3351	U8	x10msec	Maximum allowable time for which wheel angle readings between MAIN and SAFETY micro-controllers are allowed to be out of specified value	OEM	0	255	10	S
Channel cross-check monitoring - Max wheel angle divergence	P3352	U16	IR	Max allowable wheel angle reading difference between MAIN and SAFETY micro-controllers	OEM	0	2000	100	S
Channel cross-check monitoring - Max SASA angle divergence time	P3354	U8	x10msec	Maximum allowable time for steering wheel angle readings between MAIN and SAFETY micro-controllers are allowed to be out of specified value	OEM	0	255	10	S
Channel cross-check monitoring - Max SASA angle divergence	P3355	U16	Deg	Max allowable steering wheel reading difference between MAIN and SAFETY micro-controllers	OEM	0	360	15	S
Channel cross-check monitoring - Max SASA velocity divergence time	P3357	U8	x10msec	Maximum allowable time for steering wheel velocity between MAIN and SAFETY micro-controllers are allowed to be out of specified value	OEM	0	255	10	S
Channel cross-check monitoring - Max SASA velocity divergence	P3358	U16	dRpm	Max allowable steering wheel velocity difference between MAIN and SAFETY micro-controllers	OEM	0	4800	50	S
Channel cross-check monitoring - Max calc flow command divergence time	P3360	U8	x10msec	Maximum allowable time for spool position set-point between MAIN and SAFETY micro-controllers are allowed to be out of specified value	OEM	0	255	10	S
Channel cross-check monitoring - Max calc flow command divergence	P3361	U16	IR	Max allowable flow command difference in IR between MAIN and SAFETY micro-controllers	OEM	0	2000	100	S
Channel cross-check monitoring - Max vehicle speed divergence time	P3363	U8	x10msec	Maximum allowable time for which vehicle speed readings between MAIN and SAFETY micro-controllers are allowed to be out of specified value	OEM	0	255	10	S
Channel cross-check monitoring - Max vehicle speed divergence	P3364	U8	km/h	Max allowable vehicle speed reading difference between MAIN and SAFETY micro-controllers	OEM	0	100	5	S
Channel cross-check monitoring - Max AUX mini-steering wheel velocity divergence time	P3365	U8	x10mSec	Maximum allowable time for AUX mini-steering wheel velocity between MAIN and SAFETY micro-controllers are allowed to be out of specified value	OEM	0	255	10	S
Channel cross-check monitoring - Max AUX mini-steering wheel velocity divergence	P3366	U16	dRpm	Max allowable AUX steering wheel velocity difference between MAIN and SAFETY micro-controllers	OEM	0	4800	50	S
Channel cross-check monitoring - Max AUX joystick position divergence time	P3368	U8	x10mSec	Maximum allowable time for AUX joystick position request between MAIN and SAFETY micro-controllers are allowed to be out of specified value	OEM	0	255	10	S
Channel cross-check monitoring - Max AUX joystick position divergence	P3369	U16	IR	Max allowable AUX joystick position request difference between MAIN and SAFETY micro-controllers	OEM	0	2000	100	S
Channel cross-check monitoring - Max AUX mini-steering wheel angle divergence time	P3371	U8	x10mSec	Maximum allowable time for AUX mini-steering wheel Angle between MAIN and SAFETY micro-controllers are allowed to be out of specified value	OEM	0	255	10	S
Channel cross-check monitoring - Max AUX mini-steering wheel angle divergence	P3372	U16	Deg	Max allowable AUX steering wheel Angle difference between MAIN and SAFETY micro-controllers	OEM	0	360	15	S
Channel cross-check monitoring - Max MMI command divergence time	P3374	U8	x10msec	Maximum allowable time for which MMI Flag readings between MAIN and SAFETY micro-controllers are allowed to be different	OEM	0	255	10	S
Channel cross-check monitoring - Max analogue sensor divergence (internal)	P3375	U16	IR	Max allowed difference between analogue sensors values measured by primary and redundant analogue sensors	OEM	0	2000	50	S
Spool monitoring - Max difference between spool set-point and spool position	P3377	U8	x10u Meter	Max allowed difference between Spool set-point and actual spool position used for Spool monitoring algorithm	OEM	0	200	80	S



Spool monitoring - Min 'spool out of control' tolerance time	P3378	U8	x10mSec	Minimum timeout value used by spool monitoring algorithm	OEM	1	75	15	S
Spool monitoring - Max "spool out of control" tolerance time	P3379	U16	x10mSec	Maximum timeout value used by spool monitoring algorithm	OEM	100	400	100	S
Spool monitoring – confidence time decrease rate	P3381	U16	-	Spool Monitoring time constant	OEM	0	60000	8000	S
Channel cross-check monitoring - max Road switch position divergence time	P3383	U8	x10mSec	Timeout value for Safe ON-ROAD switch position, cross check between MAIN- and SAFETY-controller. Resolution: 1 x10mSec = 10ms	OEM	0	255	10	S
Scaled Analogue sensor limit offset	P3384	U16	IR	The analogue sensor output conversions to internal resolution [IR] is limited to ±1000, based on the calibration parameters. But internally it is checked that the un-clamped analogue sensor signal does not exceeds the range: $(-1000 - P3384 [IR]) < \text{"un-clamped analogue sensor signal"} < (1000 + P3384 [IR])$	OEM	0	1000	50	S
Severity level for temperature monitoring	P3386	U8	-	Severity Level for temperature monitoring Valid Values: 0 (Severity level: Critical) 255 (Severity level: INFO)	OEM	0	255	0	
Channel cross-check monitoring - Max AUX joystick engage divergence time	P3387	U8	x10mSec	Maximum allowable time for which AUX Joystick Enable signals between MAIN and SAFETY micro-controllers are allowed to be different	OEM	0	255	10	S
Channel cross-check monitoring - Max AUX joystick trim divergence time	P3388	U8	x10mSec	Maximum allowable time for which AUX Joystick Trim signals between MAIN and SAFETY micro-controllers are allowed to be different	OEM	0	255	10	S
Channel cross-check monitoring - Max AUX joystick trim divergence	P3389	U8	IR	Max allowable AUX Joystick Trim difference between MAIN and SAFETY micro-controllers	OEM	0	255	50	S
Wheel angle limit offset (CAN WAS)	P3390	U16	IR	The CAN Wheel angle sensor output conversions to internal resolution [IR] is limited to ±1000 IR, based on the calibration parameters. But internally it is checked that the un-clamped CAN Wheel angle sensor signal does not exceeds the range: $(-1000 - P3390 [IR]) < \text{"un-clamped analogue sensor signal"} < (1000 + P3390 [IR])$	OEM	0	1000	50	S
Channel cross-check monitoring - Max WAS auto-calibrated cylinder stroke volume difference	P3392	U16	ccm	Maximum WAS Auto-calibrated Cylinder Stroke Volume Difference	OEM	1	10000	50	
Channel cross-check monitoring - Max WAS auto-calibrated wheel angle difference	P3394	U8	deg	Maximum WAS Auto-calibrated wheel angle Difference	OEM	1	89	3	
Channel cross-check monitoring - Max IMD STW status divergence time	P3395	U8	x10mSec	Maximum allowable time for which IMD STW Status between MAIN and SAFETY micro-controllers are allowed to be different	OEM	0	255	10	S

Table 71



17.4.9 Vehicle Geometry

Name	Address	Data type	Unit	Description of parameter	User	Range		Danfoss default value	Safety critical parameters 'S'
						Min.	Max.		
Vehicle steering type	P3421	U8	-	Vehicle steering type Valid Values: 1 (TWO WHEEL/ACKERMANN); 2 (ARTICULATED)	OEM, Dealer	1	2	1	
Wheel base A	P3422	U16	mm	Distance between the axles (front or rear wheel steered vehicle only) or between an axle and the articulation point (articulated vehicles only)	OEM, Dealer	1000	10000	4000	
Wheel base B	P3424	U16	mm	Distance between the other axle and the articulation point (articulated vehicles only)	OEM, Dealer	1000	10000	4000	
Maximum steer angle, left	P3426	U16	Deg	Maximum steer angle to left side Note: Writing values >89 will force to use automatic adjusted maximum steer angle, Left-value on WAS calibration	OEM, Dealer	0	65535	35	
Maximum steer angle, right	P3428	U16	Deg	Maximum steer angle to right side Note: Writing values >89 will force to use automatic adjusted maximum steer angle, Right-value on WAS calibration	OEM, Dealer	0	65535	35	

Table 72



17.4.10 GPS Config

Name	Address	Data type	Unit	Description of parameter	User	Range		Danfoss default value	Safety critical parameters 'S'
						Min.	Max.		
GPS - Max flow @ Point D	P3451	U16	IR	Auto-guidance mode - Maximum allowed flow at the vehicle speed of 0 km/h	OEM	0	1000	1000	S
GPS - Vehicle speed limiting flow @ Point E	P3453	U16	km/h	Auto-guidance mode - Vehicle speed at which the flow should be limited to "GPS - Max flow @ Point E "	OEM	0	100	15	S
GPS - Max flow @ Point E	P3455	U16	IR	Auto-guidance mode - Maximum allowed flow at the vehicle speed "GPS - Vehicle speed limiting flow @ Point E "	OEM	0	1000	50	S
GPS - Vehicle speed limiting flow @ Point F	P3457	U16	km/h	Auto-guidance mode - Vehicle speed at which the flow should be limited to "GPS - Max flow @ Point F "	OEM	0	100	25	S
GPS - Max flow @ Point F	P3459	U16	IR	Auto-guidance mode - Maximum allowed flow at the vehicle speed "GPS - Vehicle speed limiting flow @ Point F "	OEM	0	1000	25	S
GPS - Max wheel angle speed @ Point D	P3451	U16	dDeg/s	Auto-guidance mode Maximum allowed wheel angle speed at the vehicle speed of 0 km/h, @ Point D	OEM	0	1000	1000	S
GPS - Vehicle speed limiting wheel angle speed @ Point E	P3453	U16	km/h	Auto-guidance mode Vehicle speed at which the wheel angle speed should be limited, @ Point E	OEM	0	100	15	S
GPS - Max wheel angle speed @ Point E	P3455	U16	dDeg/s	Auto-guidance mode Maximum allowed wheel angle speed @ Point E	OEM	0	1000	50	S
GPS - Vehicle speed limiting wheel angle speed @ Point F	P3457	U16	km/h	Auto-guidance mode Vehicle speed at which the wheel angle speed should be limited @ Point F	OEM	0	100	25	S
GPS - Max wheel angle speed @ Point F	P3459	U16	dDeg/s	Auto-guidance mode Maximum allowed wheel angle speed @ Point F	OEM	0	1000	25	S
GPS - Max wheel angle @ Point G	P3461	U16	Deg	Auto-guidance mode - Maximum allowed wheel angle at the vehicle speed of 0 km/h	OEM	0	89	35	S
GPS - Vehicle speed limiting wheel angle @ Point H	P3463	U16	km/h	Auto-guidance mode - Vehicle speed at which the flow should be limited to "GPS - Max wheel @ Point H"	OEM	0	100	15	S
GPS - Max wheel angle @ Point H	P3465	U16	Deg	Auto-guidance mode - Maximum allowed wheel angle at the vehicle speed "GPS - Vehicle speed limiting @ Point H"	OEM	0	89	15	S
GPS - Vehicle speed limiting wheel angle @ Point I	P3467	U16	km/h	Auto-guidance mode - Vehicle speed at which the flow should be limited to "GPS - Max wheel @ Point I"	OEM	0	100	25	S
GPS - Max wheel angle @ Point I	P3469	U16	Deg	Auto-guidance mode - Maximum allowed wheel angle at the vehicle speed "GPS - Vehicle speed limiting @ Point I"	OEM	0	89	10	S
GPS – CL gain @ Point P	P3473	U8	%	Auto-guidance mode - Close loop proportional gain at 0 km/h	OEM	0	200	50	S
GPS – CL gain @ Point Q	P3474	U8	%	Auto-guidance mode - Close loop proportional gain at "GPS – Vehicle speed @ Point Q"	OEM	0	200	50	S
GPS – CL gain @ Point R	P3475	U8	%	Auto-guidance mode - Close loop proportional gain at "GPS – Vehicle speed @ Point R"	OEM	0	200	50	S
GPS – CL gain @ Point S	P3476	U8	%	Auto-guidance mode - Close loop proportional gain at "GPS – Vehicle speed @ Point S"	OEM	0	200	50	S
GPS – CL gain @ Point T	P3477	U8	%	Auto-guidance mode - Close loop proportional gain at "GPS – Vehicle speed @ Point T"	OEM	0	200	50	S
GPS – CL gain @ Point U	P3478	U8	%	Auto-guidance mode - Close loop proportional gain at "GPS – Vehicle speed @ Point U"	OEM	0	200	50	S
GPS – Vehicle speed @ Point Q	P3479	U8	km/h	Auto-guidance mode – Vehicle speed at "GPS – CL gain @ Point Q"	OEM	0	100	30	S
GPS – Vehicle speed @ Point R	P3480	U8	km/h	Auto-guidance mode – Vehicle speed at "GPS – CL gain @ Point R"	OEM	0	100	31	S
GPS – Vehicle speed @ Point S	P3481	U8	km/h	Auto-guidance mode – Vehicle speed at "GPS – CL gain @ Point S"	OEM	0	100	32	S
GPS – Vehicle speed @ Point T	P3482	U8	km/h	Auto-guidance mode – Vehicle speed at "GPS – CL gain @ Point T"	OEM	0	100	33	S
GPS – Vehicle speed @ Point U	P3483	U8	km/h	Auto-guidance mode – Vehicle speed at "GPS – CL gain @ Point U"	OEM	0	100	34	S
GPS - Flow command filter frequency	P3484	U8	dHz	Auto-guidance Flow command filter cut-off frequency	OEM	0	200	0	
GPS2 – CL gain @ Point P	P3485	U8	%	Second auto-guidance controller mode - Close loop proportional gain at 0 km/h	OEM	0	200	50	S
GPS2 – CL gain @ Point Q	P3486	U8	%	Second auto-guidance controller mode - Close loop proportional gain at "GPS2 – Vehicle speed @ Point Q"	OEM	0	200	50	S
GPS2 – CL gain @ Point R	P3487	U8	%	Second auto-guidance controller mode - Close loop proportional gain at "GPS2 – Vehicle speed @ Point R"	OEM	0	200	50	S
GPS2 – CL gain @ Point S	P3488	U8	%	Second auto-guidance controller mode - Close loop proportional gain at "GPS2 – Vehicle speed @ Point S"	OEM	0	200	50	S
GPS2 – CL gain @ Point T	P3489	U8	%	Second auto-guidance controller mode - Close loop proportional gain at "GPS2 – Vehicle speed @ Point T"	OEM	0	200	50	S
GPS2 – CL gain @ Point U	P3490	U8	%	Second auto-guidance controller mode - Close loop proportional gain at "GPS2 – Vehicle speed @ Point U"	OEM	0	200	50	S



GPS2 – Vehicle speed @ Point Q	P3491	U8	km/h	Second auto-guidance controller mode – Vehicle speed at “GPS2 – CL gain @ Point Q”	OEM	0	100	30	S
GPS2 – Vehicle speed @ Point R	P3492	U8	km/h	Second auto-guidance controller mode – Vehicle speed at “GPS2 – CL gain @ Point R”	OEM	0	100	31	S
GPS2 – Vehicle speed @ Point S	P3493	U8	km/h	Second auto-guidance controller mode – Vehicle speed at “GPS2 – CL gain @ Point S”	OEM	0	100	32	S
GPS2 – Vehicle speed @ Point T	P3494	U8	km/h	Second auto-guidance controller mode – Vehicle speed at “GPS2 – CL gain @ Point T”	OEM	0	100	33	S
GPS2 – Vehicle speed @ Point U	P3495	U8	km/h	Second auto-guidance controller mode – Vehicle speed at “GPS2 – CL gain @ Point U”	OEM	0	100	34	S
GPS – Algorithm type	P3496	U16	-	Vehicle speed dependent flow limitation value = 0 => GPS v1 Vehicle speed dependent wheel angle speed limitation = 1 => GPS v2	OEM	0	1	0	S

Table 73

Important

For the GPS sector some rules apply to the parameter settings of the vehicle speed dependent functions. See list of rules in section 12.

17.4.11 STW Config

Name	Address	Data type	Unit	Description of parameter	User	Range		Danfoss default value	Safety critical parameters ‘S’
						Min.	Max.		
STW - Steering wheel no-activation threshold	P3521	U8	dRpm	Min steering angle velocity value below which the angle velocity of 0 is used by the STW control algorithm	OEM	0	100	5	S
STW 1 - No of turns @ Point A	P3522	U16	-	Program1 - Number of steering wheel turns lock to lock at the vehicle speed of 0 km/h Resolution = 0.01; 1turn = 100	OEM	10	800	800	S
STW 1 - No of turns @ Point B	P3524	U16	-	Program1 - Number of steering wheel turns lock to lock at the vehicle speed of “STW 1 - Vehicle speed @ Point B” Resolution = 0.01; 1turn = 100	OEM	10	800	800	S
STW 1 - No of turns @ Point C	P3526	U16	-	Program1 - Number of steering wheel turns lock to lock at the vehicle speed of “STW 1 - Vehicle speed @ Point C” Resolution = 0.01; 1turn = 100	OEM	10	800	800	S
STW 1 - Vehicle speed @ Point B	P3528	U8	km/h	Program1 - Vehicle speed at which lock to lock steering wheel turns = “STW 1 - No of turns @ Point B”	OEM	1	100	5	S
STW 1 - Vehicle speed @ Point C	P3529	U8	km/h	Program1: Vehicle speed at which lock to lock steering wheel turns = “STW 1 - No of turns @ Point C”	OEM	1	100	10	S
STW 2 - No of turns @ Point A	P3530	U16	-	Program2 - Number of steering wheel turns lock to lock at the vehicle speed of 0 km/h Resolution = 0.01; 1turn = 100	OEM	10	800	800	S
STW 2 - No of turns @ Point B	P3532	U16	-	Program2 - Number of steering wheel turns lock to lock at the vehicle speed of “STW 2 - Vehicle speed @ Point B” Resolution = 0.01; 1turn = 100	OEM	10	800	800	S
STW 2 - No of turns @ Point C	P3534	U16	-	Program2 - Number of steering wheel turns lock to lock at the vehicle speed of “STW 2 - Vehicle speed @ Point C” Resolution = 0.01; 1turn = 100	OEM	10	800	800	S
STW 2 - Vehicle speed @ Point B	P3536	U8	km/h	Program2 - Vehicle speed at which lock to lock steering wheel turns = “STW 2 - No of turns @ Point B”	OEM	1	100	5	S
STW 2 - Vehicle speed @ Point C	P3537	U8	km/h	Program2: Vehicle speed at which lock to lock steering wheel turns = “STW 2 - No of turns @ Point C”	OEM	1	100	10	S
STW 3 - No of turns @ Point A	P3538	U16	-	Program3 - Number of steering wheel turns lock to lock at the vehicle speed of 0 km/h Resolution = 0.01; 1turn = 100	OEM	10	800	800	S
STW 3 - No of turns @ Point B	P3540	U16	-	Program3 - Number of steering wheel turns lock to lock at the vehicle speed of “STW 3 - Vehicle speed @ Point B” Resolution = 0.01; 1turn = 100	OEM	10	800	800	S
STW 3 - No of turns @ Point C	P3542	U16	-	Program3 - Number of steering wheel turns lock to lock at the vehicle speed of “STW 3 - Vehicle speed @ Point C” Resolution = 0.01; 1turn = 100	OEM	10	800	800	S
STW 3 - Vehicle speed @ Point B	P3544	U8	km/h	Program3 - Vehicle speed at which lock to lock steering wheel turns = “STW 3 - No of turns @ Point B”	OEM	1	100	5	S
STW 3 - Vehicle speed @ Point C	P3545	U8	km/h	Program3: Vehicle speed at which lock to lock steering wheel turns = “STW 3 - No of turns @ Point C”	OEM	1	100	10	S
STW 4 - No of turns @ Point A	P3546	U16	-	Program4 - Number of steering wheel turns lock to lock at the vehicle speed of 0 km/h	OEM	10	800	800	S



				Resolution = 0.01; 1turn = 100					
STW 4 - No of turns @ Point B	P3548	U16	-	Program4 - Number of steering wheel turns lock to lock at the vehicle speed of "STW 4 - Vehicle speed @ Point B" Resolution = 0.01; 1turn = 100	OEM	10	800	800	S
STW 4 - No of turns @ Point C	P3550	U16	-	Program4 - Number of steering wheel turns lock to lock at the vehicle speed of "STW 4 - Vehicle speed @ Point C" Resolution = 0.01; 1turn = 100	OEM	10	800	800	S
STW 4 - Vehicle speed @ Point B	P3552	U8	km/h	Program4 - Vehicle speed at which lock to lock steering wheel turns = "STW 4 - No of turns @ Point B"	OEM	1	100	5	S
STW 4 - Vehicle speed @ Point C	P3553	U8	km/h	Program4: Vehicle speed at which lock to lock steering wheel turns = "STW 4 - No of turns @ Point C"	OEM	1	100	10	S
STW 5 - No of turns @ Point A	P3554	U16	-	Program5 - Number of steering wheel turns lock to lock at the vehicle speed of 0 km/h Resolution = 0.01; 1turn = 100	OEM	10	800	800	S
STW 5 - No of turns @ Point B	P3556	U16	-	Program5 - Number of steering wheel turns lock to lock at the vehicle speed of "STW 5 - Vehicle speed @ Point B" Resolution = 0.01; 1turn = 100	OEM	10	800	800	S
STW 5 - No of turns @ Point C	P3558	U16	-	Program5 - Number of steering wheel turns lock to lock at the vehicle speed of "STW 5 - Vehicle speed @ Point C" Resolution = 0.01; 1turn = 100	OEM	10	800	800	S
STW 5 - Vehicle speed @ Point B	P3560	U8	km/h	Program5 - Vehicle speed at which lock to lock steering wheel turns = "STW 5 - No of turns @ Point B"	OEM	1	100	5	S
STW 5 - Vehicle speed @ Point C	P3561	U8	km/h	Program5: Vehicle speed at which lock to lock steering wheel turns = "STW 5 - No of turns @ Point C"	OEM	1	100	10	S
STW soft-stop wheel angle region start	P3562	U16	IR	Defines the wheel angle region start, from the max possible wheel angle towards 0, in which the soft stop has to be applied	OEM	0	1000	400	
STW soft-stop max flow @ cylinder end-stop	P3564	U16	IR	Oil flow to deliver at the max possible wheel angle	OEM	0	1000	0	
STW soft-stop wheel angle region end	P3566	U16	IR	Defines the wheel angle region end, from the max possible wheel angle towards 0, in which the soft stop region shall end	OEM	0	1000	0	
STW anti-drift - Max steering wheel drift correction	P3568	U8	Deg	The difference between the observed and ideal STW steering angle at which and above which the max. EFU correction ("STW Anti-drift - Max flow correction") shall be applied.	OEM	1	160	20	
STW anti-drift - Max flow correction in percentage of full flow	P3569	U8	%	Max flow correction which can be requested by the EFU algorithm	OEM	0	100	15	
Backlash region	P3570	U8	dDeg	Backlash limit to use in the backlash filter in the steering wheel control algorithm Resolution: 1dDeg = 0.1Deg	OEM	0	200	5	
STW anti-jerk function	P3571	U8	-	Defines the type of the anti-jerk functionality to use 0 for Anti Jerk type NONE and 1 for Anti Jerk type 1	OEM	0	1	0	
STW relative set-point change, out from spool neutral position	P3572	U8	%	Relative set-point change allowed to apply when ramping the spool position set-point out, i.e. further out from the spool neutral position [%]	OEM	0	100	5	
STW relative set-point change, in towards spool neutral position	P3573	U8	%	Relative set-point change allowed to apply when ramping the spool position set-point in, i.e. towards the spool neutral position [%]	OEM	0	100	5	
STW absolute set-point change, out from spool neutral position	P3574	U16	IR	Set-point change allowed to apply when ramping the spool position set-point out, i.e. further out from the spool neutral position	OEM	1	1000	15	
STW absolute set-point change, in towards spool neutral position	P3576	U16	IR	Set-point change allowed to apply when ramping the spool position set-point in, i.e. towards the spool neutral position	OEM	1	1000	10	
STW anti-jerk cross-over start point	P3578	U16	IR	STW Anti-jerk Cross-over start	OEM	0	1000	10	
STW anti-jerk cross-over stop point	P3580	U16	IR	STW Anti-jerk Cross-over stop	OEM	0	1000	10	
STW anti-jerk low pass filter cut-off frequency	P3582	U8	dHz	STW Anti-jerk low pass filter cut-off frequency Resolution: 1 dHz = 0.1 Hz	OEM	5	200	100	
STW in use - Velocity threshold	P3583	U8	dRpm	Steering wheel velocity threshold	OEM	1	100	5	S
STW in use - Angle threshold	P3584	U8	Deg	Steering wheel position change threshold, from last detected position at 0 RPM	OEM	0	45	10	S
Native wheel angle range for steering wheel programs	P3585	U8	deg	Lock to lock wheel angle range Used internally to maintain the steering sensitivity/aggressiveness when physical max wheel angle endpoints are changed	OEM	0	255	255	S
IMD - EH-Steering disengage confidence limit	P3586	U8	x10mSec	Timeout value to declare steering movements to be active if EH-Spool stays within the limit specified by P3090.	OEM	0	255	30	S
IMD - EH-Spool in neutral confidence limit	P3587	U8	x10mSec	If EH-Spool stays within the threshold specified by P3090 for the timeout value specified by P3590, IMD overrules EH-Steering algorithms and takes over spool control to evaluate spool position.	OEM	0	255	15	S
IMD - Dynamic SVC integral limit	P3588	U8	-	Dynamic SVC integral limit to use while EH-Spool is close to neutral	OEM	0	255	10	S
IMD - Dynamic SVC integral gain	P3589	U16	-	Dynamic SVC integral gain to use while EH-Spool is close to neutral.	OEM	0	65535	225	S

Table 74

Important

For the STW sector some rules apply to the parameter settings of the vehicle speed dependent functions. See list of rules in section 10.



17.4.12 AUX Config

Name	Address	Data type	Unit	Description of parameter	User	Range		Danfoss default value	Safety critical parameters 'S'
						Min.	Max.		
AUX mini-steering in use - Velocity threshold	P3646	U8	dRpm	AUX mini-steering velocity threshold to declare that the steering is in use	OEM	0	100	15	S
AUX joystick in use - Flow command threshold	P3647	U8	IR	AUX Joystick flow command threshold to declare that joystick is in use	OEM	0	100	10	S
AUX -Joystick no-activation threshold	P3648	U8	IR	Min Flow command from AUX joystick below which the flow command of 0 is used by the AUX control algorithm	OEM	0	100	5	S
AUX - Mini-steering no-activation threshold	P3649	U8	dRpm	Min AUX steering angle velocity value below which the angle velocity of 0 is used by the AUX control algorithm	OEM	0	100	5	S
AUX mini-steering 1 - No of turns @ Point J	P3650	U16	-	Program1 - Number of steering wheel turns lock to lock at the vehicle speed of 0 km/h Resolution = 0.01; Iturn = 100	OEM	10	800	800	S
AUX mini-steering 1 - No of turns @ Point K	P3652	U16	-	Program1 - Number of steering wheel turns lock to lock at the vehicle speed of "AUX program 1 - Vehicle speed @ Point K" Resolution = 0.01; Iturn = 100	OEM	10	800	800	S
AUX mini-steering 1 - No of turns @ Point L	P3654	U16	-	Program1 - Number of steering wheel turns lock to lock at the vehicle speed of "AUX program 1 - Vehicle speed @ Point L" Resolution = 0.01; Iturn = 100	OEM	10	800	800	S
AUX mini-steering 1 - Vehicle speed @ Point K	P3656	U8	km/h	Program1 - Vehicle speed at which lock to lock steering wheel turns = "AUX program 1 - No of turns @ Point K"	OEM	1	100	5	S
AUX mini-steering 1 - Vehicle speed @ Point L	P3657	U8	km/h	Program1: Vehicle speed at which lock to lock steering wheel turns = "AUX program 1 - No of turns @ Point L"	OEM	1	100	10	S
AUX mini-steering 2 - No of turns @ Point J	P3658	U16	-	Program2 - Number of steering wheel turns lock to lock at the vehicle speed of 0 km/h Resolution = 0.01; Iturn = 100	OEM	10	800	800	S
AUX mini-steering 2 - No of turns @ Point K	P3660	U16	-	Program2 - Number of steering wheel turns lock to lock at the vehicle speed of "AUX program 2 - Vehicle speed @ Point K" Resolution = 0.01; Iturn = 100	OEM	10	800	800	S
AUX mini-steering 2 - No of turns @ Point L	P3662	U16	-	Program2 - Number of steering wheel turns lock to lock at the vehicle speed of "AUX program 2 - Vehicle speed @ Point L" Resolution = 0.01; Iturn = 100	OEM	10	800	800	S
AUX mini-steering 2 - Vehicle speed @ Point K	P3664	U8	km/h	Program2 - Vehicle speed at which lock to lock steering wheel turns = "AUX program 2 - No of turns @ Point K"	OEM	1	100	5	S
AUX mini-steering 2 - Vehicle speed @ Point L	P3665	U8	km/h	Program2: Vehicle speed at which lock to lock steering wheel turns = "AUX program 2 - No of turns @ Point L"	OEM	1	100	10	S
AUX mini-steering 3 - No of turns @ Point J	P3666	U16	-	Program3 - Number of steering wheel turns lock to lock at the vehicle speed of 0 km/h Resolution = 0.01; Iturn = 100	OEM	10	800	800	S
AUX mini-steering 3 - No of turns @ Point K	P3668	U16	-	Program3 - Number of steering wheel turns lock to lock at the vehicle speed of "AUX program 3 - Vehicle speed @ Point K" Resolution = 0.01; Iturn = 100	OEM	10	800	800	S
AUX mini-steering 3 - No of turns @ Point L	P3670	U16	-	Program3 - Number of steering wheel turns lock to lock at the vehicle speed of "AUX program 3 - Vehicle speed @ Point L" Resolution = 0.01; Iturn = 100	OEM	10	800	800	S
AUX mini-steering 3 - Vehicle speed @ Point K	P3672	U8	km/h	Program3 - Vehicle speed at which lock to lock steering wheel turns = "AUX program 3 - No of turns @ Point K"	OEM	1	100	5	S
AUX mini-steering 3 - Vehicle speed @ Point L	P3673	U8	km/h	Program3: Vehicle speed at which lock to lock steering wheel turns = "AUX program 3 - No of turns @ Point L"	OEM	1	100	10	S
AUX mini-steering 4 - No of turns @ Point J	P3674	U16	-	Program4 - Number of steering wheel turns lock to lock at the vehicle speed of 0 km/h Resolution = 0.01; Iturn = 100	OEM	10	800	800	S
AUX mini-steering 4 - No of turns @ Point K	P3676	U16	-	Program4 - Number of steering wheel turns lock to lock at the vehicle speed of "AUX program 4 - Vehicle speed @ Point K" Resolution = 0.01; Iturn = 100	OEM	10	800	800	S
AUX mini-steering 4 - No of turns @ Point L	P3678	U16	-	Program4 - Number of steering wheel turns lock to lock at the vehicle speed of "AUX program 4 - Vehicle speed @ Point L" Resolution = 0.01; Iturn = 100	OEM	10	800	800	S
AUX mini-steering 4 - Vehicle speed @ Point K	P3680	U8	km/h	Program4 - Vehicle speed at which lock to lock steering wheel turns = "AUX program 4 - No of turns @ Point K"	OEM	1	100	5	S
AUX mini-steering 4 - Vehicle speed @ Point L	P3681	UNSI GNE D 8	km/h	Program4: Vehicle speed at which lock to lock steering wheel turns = "AUX program 4 - No of turns @ Point L"	OEM	1	100	10	S



AUX mini-steering 5 - No of turns @ Point J	P3682	U16	-	Program5 - Number of steering wheel turns lock to lock at the vehicle speed of 0 km/h Resolution = 0.01; Iturn = 100	OEM	10	800	800	S
AUX mini-steering 5 - No of turns @ Point K	P3684	U16	-	Program5 - Number of steering wheel turns lock to lock at the vehicle speed of "AUX program 5 - Vehicle speed @ Point K" Resolution = 0.01; Iturn = 100	OEM	10	800	800	S
AUX mini-steering 5 - No of turns @ Point L	P3686	U16	-	Program5 - Number of steering wheel turns lock to lock at the vehicle speed of "AUX program 5 - Vehicle speed @ Point L" Resolution = 0.01; Iturn = 100	OEM	10	800	800	S
AUX mini-steering 5 - Vehicle speed @ Point K	P3688	U8	km/h	Program5 - Vehicle speed at which lock to lock steering wheel turns = "AUX program 5 - No of turns @ Point K"	OEM	1	100	5	S
AUX mini-steering 5 - Vehicle speed @ Point L	P3689	U8	km/h	Program5: Vehicle speed at which lock to lock steering wheel turns = "AUX program 5 - No of turns @ Point L"	OEM	1	100	10	S
AUX joystick - Flow limit for max joystick command @ Point M	P3690	U16	IR	Aux Joystick: flow limit for maximum joystick command at Vehicle speed of 0 km/h	OEM	0	1000	1000	S
AUX joystick - Flow limit for max joystick command @ Point N	P3692	U16	IR	Aux Joystick - flow limit for maximum joystick command at the vehicle speed of "Aux Joystick - Vehicle speed @ Point N"	OEM	0	1000	50	S
AUX joystick - Flow limit for max joystick command @ Point O	P3694	U16	IR	Aux Joystick - flow limit for maximum joystick command at the vehicle speed of "Aux Joystick - Vehicle speed @ Point O"	OEM	0	1000	25	S
AUX joystick - Vehicle speed @ Point N	P3696	U8	km/h	Aux Joystick - Vehicle speed to limit the flow @ point N for maximum joystick command	OEM	0	100	15	S
AUX joystick - Vehicle speed @ Point O	P3697	U8	km/h	Aux Joystick - Vehicle speed to limit the flow @ point O for maximum joystick command	OEM	0	100	25	S
AUX anti-jerk function	P3698	U8	-	Defines the type of the anti-jerk functionality to use 0 for Anti Jerk type NONE and 1 for Anti Jerk type 1	OEM	0	1	0	
AUX relative set-point change, in towards spool neutral position	P3699	U8	%	Relative set-point change allowed to apply when ramping the spool position set-point out, i.e. further out from the spool neutral position [%]	OEM	0	100	5	
AUX relative set-point change, out from spool neutral position	P3700	U8	%	Relative set-point change allowed to apply when ramping the spool position set-point in, i.e. towards the spool neutral position [%]	OEM	0	100	5	
AUX absolute set-point change, in towards spool neutral position	P3701	U16	IR	Set-point change allowed to apply when ramping the spool position set-point out, i.e. further out from the spool neutral position	OEM	1	1000	10	
AUX absolute set-point change, out from spool neutral position	P3703	U16	IR	Set-point change allowed to apply when ramping the spool position set-point in, i.e. towards the spool neutral position	OEM	1	1000	15	
AUX anti-drift - Max flow correction in percentages of full flow	P3705	U8	%	Max flow correction which can be requested by the EFU algorithm. If anti-drift is not needed, the function can be disabled by setting P3705 to 0	OEM	0	100	15	
AUX anti-drift - Max steering wheel drift correction	P3706	U16	Deg	The difference between the observed and ideal AUX steering angle at which and above which the max. EFU correction ("AUX Anti-drift - Max flow correction") shall be applied.	OEM	1	160	20	
AUX soft-stop max flow @ cylinder end-stop	P3708	U16	IR	Oil flow to deliver at the max possible wheel angle	OEM	100	1000	200	
AUX soft-stop wheel angle region start	P3710	U16	IR	Defines the wheel angle region start, from the max possible wheel angle towards 0, in which the soft stop has to be applied	OEM	0	1000	0	
AUX soft-stop wheel angle region stop	P3712	U16	IR	Defines the wheel angle region end, from the max possible wheel angle towards 0, in which the soft stop has to be applied	OEM	0	1000	0	
AUX anti-jerk cross-over start point	P3714	U16	IR	AUX Anti-jerk Cross-over start	OEM	1	1000	10	
AUX anti-jerk cross-over stop point	P3716	U16	IR	AUX Anti-jerk Cross-over stop	OEM	1	1000	10	
AUX anti-jerk low pass filter cut-off frequency	P3718	U8	dHz	AUX Anti-jerk low pass filter cut-off frequency Resolution: 1 dHz = 0.1 Hz	OEM	5	200	100	
AUX mini-steering in use - Angle threshold	P3719	U8	Deg	AUX mini-steering wheel angle change threshold to detect steering is in use	OEM	0	45	10	S
AUX joystick - Max wheel angle @ Point A	P3720	U8	Deg	AUX Joystick - Maximum allowed wheel angle at the vehicle speed of 0 km/h	OEM	0	89	15	S
AUX joystick - Max wheel angle @ Point B	P3721	U8	Deg	AUX Joystick - Maximum allowed wheel angle at the vehicle speed "AUX Joystick - Vehicle speed limiting wheel angle @ Point B"	OEM	0	89	10	S
AUX joystick - Max wheel angle @ Point C	P3722	U8	Deg	AUX Joystick - Maximum allowed wheel angle at the vehicle speed "AUX Joystick - Vehicle speed limiting wheel angle @ Point C"	OEM	0	89	5	S
AUX joystick - Vehicle speed limiting wheel angle @ Point B	P3723	U8	km/h	AUX Joystick - Vehicle speed at which the flow should be limited to "AUX Joystick - Max wheel angle @ Point B"	OEM	0	100	15	S
AUX joystick - Vehicle speed limiting wheel angle @ Point C	P3724	U8	km/h	AUX Joystick - Vehicle speed at which the flow should be limited to "AUX Joystick - Max wheel angle @ Point C"	OEM	0	100	25	S
AUX joystick - CL gain @ Point A	P3725	U8	%	AUX Joystick - Closed loop proportional gain at 0 km/h	OEM	0	200	50	S
AUX joystick - CL gain @ Point B	P3726	U8	%	AUX Joystick - Closed loop proportional gain at "AUX Joystick - Vehicle speed @ Point B"	OEM	0	200	50	S
AUX joystick - CL gain @ Point C	P3727	U8	%	AUX Joystick - Closed loop proportional gain at "AUX Joystick - Vehicle speed @ Point C"	OEM	0	200	50	S
AUX joystick - Vehicle speed @ Point B	P3728	U8	km/h	AUX Joystick - Vehicle speed at "AUX - CL gain @ Point B"	OEM	0	100	15	S
AUX joystick - Vehicle speed @ Point C	P3729	U8	km/h	AUX Joystick - Vehicle speed at "AUX - CL gain @ Point C"	OEM	0	100	25	S



AUX joystick - Max CL steady state error threshold	P3730	U8	IR	AUX Joystick - Maximum closed loop steady state error allowed for changing steering device from AUX to auto-guidance	OEM	0	200	100	S
AUX joystick - Min time for CL steady state error threshold	P3731	U8	X10mSec	AUX Joystick - The minimum amount of time for where the CL steady state error threshold (i.e. value for P3730) should not be exceeded, for being able to change steering device from AUX to auto-guidance	OEM	0	255	50	S
AUX joystick - Max closed loop error for engaging closed loop joystick steering	P3732	U8	IR	AUX Joystick - Maximum allowed closed loop error for being able to engage closed loop AUX Joystick, when a higher priority steering device is selected.	OEM	0	2000	100	S
AUX joystick - Maximum deflection region offset	P3734	U16	IR	AUX joystick - Maximum joystick deflection region offset from scaled MAX position 1000 IR	OEM	0	1000	0	
AUX joystick - Dead-band region	P3736	U16	IR	AUX joystick - Neutral dead-band region for open loop transfer function	OEM	0	1000	0	
AUX joystick - Interpolation point X for open loop joystick transfer function	P3738	U16	IR	AUX Joystick - Interpolation point X for open loop Joystick transfer function	OEM	0	1000	1000	
AUX joystick - Interpolation point Y for open loop joystick transfer function	P3740	U16	IR	AUX Joystick - Interpolation point Y for open loop Joystick transfer function	OEM	0	1000	1000	
Native wheel angle range for AUX steering programs	P3742	U8	deg	AUX Lock to lock wheel angle range Used internally to maintain the steering sensitivity/aggressiveness when physical max wheel angle endpoints are changed by changing/adding tires	OEM	0	255	255	S

Table 75

Important

For the STW sector some rules apply to the parameter settings of the vehicle speed dependent functions. See list of rules in section 11.

17.4.13 Production/Calibration Flag

Name	Address	Data type	Unit	Description of parameter	User	Range		Danfoss default value	Safety critical parameters 'S'
						Min.	Max.		
Calibration counter - Spool calibration	P3771	U8	-	Calibration counter - Spool calibration	OEM	0	255	0	
Bit inverted value for "Calibration counter - Spool calibration"	P3772	U8	-	Bit inverted value for "Calibration counter - Spool calibration"	OEM	0	255	255	
Calibration counter - Analogue WAS calibration	P3773	U8	-	Calibration counter - Analogue WAS	OEM	0	255	0	
Bit inverted value for "Calibration counter - Analogue WAS calibration"	P3774	U8	-	Bit inverted value for "Calibration counter - Analogue WAS"	OEM	0	255	255	
Calibration counter - CAN WAS calibration	P3775	U8	-	Calibration counter - CAN WAS	OEM	0	255	0	
Bit inverted value for "Calibration counter - CAN WAS calibration"	P3776	U8	-	Bit inverted value for "Calibration counter - CAN WAS"	OEM	0	255	255	
Calibration counter - Analogue joystick	P3777	U8	-	Analogue sensor based Joystick calibration counter	OEM	0	255	0	
Bit inverted value for "Calibration counter - Analogue joystick"	P3778	U8	-	Bit inverted value for Analogue sensor based Joystick calibration counter	OEM	0	255	255	

Table 76



17.4.14 Auto Calibration Config

Name	Address	Data type	Unit	Description of parameter	User	Range		Danfoss default value	Safety critical parameters 'S'
						Min.	Max.		
Analogue sensor calibration - Max allowable analogue sensor signal to be captured in neutral	P3791	U16	mVolts	Maximum allowed signal to be captured for neutral position during Analogue sensor auto-calibration	OEM, Dealer	0	5000	4500	
Analogue sensor calibration - Min voltage needed in between the captured analogue sensor values	P3793	U16	mVolts	Determines the minimum voltage needed in between the captured Analogue sensor voltage (minimum, neutral and maximum), to ensure a sufficient high analogue signal resolution during Analogue sensor auto-calibration.	OEM, Dealer	0	2500	0	
Analogue sensor calibration - Min allowable analogue sensor signal to be captured in neutral	P3795	U16	mVolts	Minimum allowed signal to be captured for neutral position during analogue sensor auto-calibration.	OEM, Dealer	0	5000	500	
Spool calibration - Max closed loop dead-band edge	P3797	U16	x10u Meter	Maximum closed loop dead-band value (for both left- and right-side), hence the found dead-band values needs to be in between P3799 and P3797.	OEM, Dealer	0	300	300	
Spool calibration - Min closed loop dead-band edge	P3799	U16	x10u Meter	Minimum closed loop dead-band value (for both left- and right-side), hence the found dead-band values needs to be in between P3799 and P3797.	OEM, Dealer	0	300	0	
Spool calibration - Activation timeout	P3801	U8	-	The time window the user has to start the spool auto-calibration (i.e. to press the "Start Calibration" button) after the steering wheel has been activated and the motion has stopped again	OEM, Dealer	1	60	20	
Spool calibration - Initial spool position	P3802	U16	x10u Meter	The initial spool position value, the spool auto-calibration function will start at. The higher set-point, the faster the wheels movement will be. Recommend: 115 for OSPE/EHi; 200 for EHPS	OEM, Dealer	50	300	125	
Spool calibration - +/- turn range sweep	P3804	U16	dDeg	This is the +/- turn range sweep where the auto-calibration function will measure the time for when moving the spool from left to right and right to left. Resolution: 1 dDeg 1 = 0,1°.	OEM, Dealer	5	400	25	
Spool calibration - Max time for acceptable CL dead-band edge	P3806	U16	x100msec	P3806 and P3808 indicate the target sweep time for the spool calibration function, to find an acceptable closed loop dead-band edge. That maximum given time is defined by P3806	OEM, Dealer	10	600	110	
Spool calibration - Min time for acceptable CL dead-band edge	P3808	U16	x100msec	P3806 and P3808 indicate the target sweep time for the spool calibration function, to find an acceptable closed loop dead-band edge. The minimum given time is defined by P3808	OEM, Dealer	10	600	60	
Spool calibration - Vector sample size	P3810	U8	-	In most cases, to find an acceptable closed loop dead-band edge within a given time frame requires more attempts (to ensure consistency in the captured/found values). P3810 defines the vector size for how many attempts (for left- and right-side dead-band edge, respectively) should be considered	OEM, Dealer	1	10	7	
Spool calibration - Min valid samples	P3811	U8	-	P3811 defines how many of the attempts (defined by P3810) that need to be equal to get a successful spool calibration.	OEM, Dealer	1	10	5	
Spool calibration - +/- turn range sweep add-on	P3812	U16	dDeg	This indicates the additional +/- turn range, which will be added to the value in P3804. The additional turn range movement is required to obtain a stable spool position and stable wheel movement of the vehicle. The wheels will move in between this +/- turn range, but time will only be measured in between the +/- turn range specified by P3804. Resolution: 1 dDeg 1 = 0,1°.	OEM, Dealer	5	400	25	
Spool calibration - Spool set-point increase/decrease step	P3814	U8	%	When the auto-calibration function has determined if the last attempt was too slow or to fast (hence, within the time frame specified by P3806 and P3808), it will: • Too slow: add the value specified by P3814 to initial set-point value. • Too fast: subtract the value specified by P3814 to initial set-point value	OEM, Dealer	1	25	10	
WAS calibration - Mapped cyl. str. vol. (steering left) at 33% VB	P3815	U16	ccm	Mapped cylinder stroke volume (steering left) at 33% voltage base	OEM, Dealer	100	10000	333	
WAS calibration - Mapped cyl. str. vol. (steering left) at 67% VB	P3817	U16	ccm	Mapped cylinder stroke volume (steering left) at 67% voltage base	OEM, Dealer	100	10000	667	
WAS calibration - Mapped cyl. str. vol. (steering left) at 100% VB	P3819	U16	ccm	Mapped cylinder stroke volume (steering left) at 100% voltage base	OEM, Dealer	100	10000	1000	
WAS calibration - Mapped VB for cyl. str. vol. (steering left)	P3821	U16	mVolts	Mapped voltage base for cylinder stroke volume (steering left)	OEM, Dealer	0	6000	2000	
WAS calibration - Mapped cyl. str. vol. (steering right) at 33% VB	P3823	U16	ccm	Mapped cylinder stroke volume (steering right) at 33% voltage base	OEM, Dealer	100	10000	333	
WAS calibration - Mapped cyl. str. vol. (steering right) at 67% VB	P3825	U16	ccm	Mapped cylinder stroke volume (steering right) at 67% voltage base	OEM, Dealer	100	10000	667	
WAS calibration - Mapped cyl. str. vol. (steering right) at 100% VB	P3827	U16	ccm	Mapped cylinder stroke volume (steering right) at 100% voltage base	OEM, Dealer	100	10000	1000	
WAS calibration - Mapped VB for cyl. str. vol. (steering right)	P3829	U16	mVolts	Mapped voltage base for cylinder stroke volume (steering right)	OEM, Dealer	0	6000	2000	



WAS calibration - Mapped max WA (steering left) at 33% VB	P3831	U8	deg	Mapped maximum wheel angle (steering left) at 33% voltage base	OEM, Dealer	0	89	30	
WAS calibration - Mapped max WA (steering left) at 67% VB	P3832	U8	deg	Mapped maximum wheel angle (steering left) at 67% voltage base	OEM, Dealer	0	89	60	
WAS calibration - Mapped max WA (steering left) at 100% VB	P3833	U8	deg	Mapped maximum wheel angle (steering left) at 100% voltage base	OEM, Dealer	0	89	89	
WAS calibration - Mapped VB for max WA (steering left)	P3834	U16	mVolts	Mapped voltage base for maximum wheel angle (steering left)	OEM, Dealer	0	6000	2000	
WAS calibration - Mapped max WA (steering right) at 33% VB	P3836	U8	deg	Mapped maximum wheel angle (steering right) at 33% voltage base	OEM, Dealer	0	89	30	
WAS calibration - Mapped max WA (steering right) at 67% VB	P3837	U8	deg	Mapped maximum wheel angle (steering right) at 67% voltage base	OEM, Dealer	0	89	60	
WAS calibration - Mapped max WA (steering right) at 100% VB	P3838	U8	deg	Mapped maximum wheel angle (steering right) at 100% voltage base	OEM, Dealer	0	89	89	
WAS calibration - Mapped VB for max WA (steering right)	P3839	U16	mVolts	Mapped voltage base for maximum wheel angle (steering right)	OEM, Dealer	0	6000	2000	
WAS calibration - Max allowable CAN WAS signal to be captured in neutral	P3841	U16	mVolts	Maximum allowed signal to be captured for neutral position during CAN WAS auto-calibration	OEM, Dealer	0	5000	4500	
WAS calibration - Min voltage needed in between the captured CAN WAS values	P3843	U16	mVolts	Determines the minimum voltage needed in between the captured CAN WAS voltage (minimum, neutral and maximum), to ensure a sufficient high wheel angle resolution during CAN WAS auto-calibration.	OEM, Dealer	0	2500	0	
WAS calibration - Min allowable CAN WAS signal to be captured in neutral	P3845	U16	mVolts	Minimum allowed signal to be captured for neutral position during CAN WAS auto-calibration	OEM, Dealer	0	5000	500	

Table 77



17.4.15 OEM Data

PVED-CLS reserves 100 bytes of EEPROM memory locations from address P4212 to P4311 for OEMs, system integrators can use these memory addresses to store their own data like serial ID or identification data.

This EEPROM memory section is not CRC protected and no validation will be done by PVED-CLS.

Important

The addresses P4210 and P4211 are reserved for future use and shall not be used.

17.5 CRC SECTOR

17.5.1 CRC sector overview

Sector name	Start address	End address	Sector size (bytes)	Access type	CRC/Checksum calculation end address	CRC/Checksum address	CRC/signature address	PSAC
Hydraulic Config	3072	3121	50	Read/Write	3097	3120	40	OEM
SEHS FDA	3122	3161	40		3134	3160	42	OEM
Valve Calibration Data	3162	3184	23		3171	3183	44	OEM, Dealer
CAN WAS Calibration Data	3185	3204	20		3196	3203	46	OEM, Dealer
Analog Sensor Calibration Data	3205	3236	32		3226	3235	48	OEM, Dealer
Peripherals Config	3237	3286	50		3253	3285	50	OEM
SEHS Protocol Data	3287	3350	64		3330	3349	52	OEM
Internal Monitoring	3351	3420	70		3394	3419	54	OEM
Vehicle Geometry	3421	3450	30		3429	3449	56	OEM, Dealer
GPS Config	3451	3520	70		3495	3519	58	OEM
STW Config	3521	3645	125		3585	3644	60	OEM
AUX Config	3646	3770	125		3742	3769	62	OEM
Production/Calibration Flag	3771	3790	20		3778	3789	-	OEM
Auto Calibration Config	3791	3863	73		3846	3862	64	OEM, Dealer
OEM Data	4212	4311	100		-	-	-	-

Table 78

Warning



Danfoss recommends not modifying data outside the specified address ranges shown in Table 78 as it will be detected by the PVED-CLS and lead to safe state!

17.5.2 Sector CRC calculation

Upon having verified the correctness of the data in a given sector, the sector CRC shall be calculated and stored at the CRC address. The CRC shall be calculated in accordance with CRC-CCITT polynomial, $x^{16} + x^{12} + x^5 + 1$ (0x1021).

17.5.3 Example

Example for calculating the sector CRC for “Valve calibration data”:

Name	Address	Data type	Description of parameter	Value Dec	Value Hex
Max spool position, left	P3162	S16	Spool left most position	-420	FE5Ch
Max spool position, right	P3164	S16	Spool right most position	420	01A4h
Closed loop dead-band edge, left	P3166	S16	Spool closed loop dead-band edge, Left	-105	FF97h
Closed loop dead-band edge, right	P3168	S16	Spool closed loop dead-band edge, Right	105	0069h
Open loop dead-band edge offset	P3170	S16	Spool open loop dead-band offset	25	0019h
Sector CRC	P3183	U16	CRC value for the valve calibration sector		F934h

Table 79

The data that is target for the CRC calculation is given in Table 79. The last byte that shall be included in the CRC calculation is P3171 which holds the high byte of the Offset Dead-band OL parameter. Unused byte may be set to 0. To calculate the sector CRC, the data is first rearranged into little endian format as follows: “5CFEA40197FF69001900”. The CRC-CCITT result for this data is F934h. The low byte (34h) shall be stored at P3183 and the high byte (F9h) at P3184.

17.5.4 Signature CRC calculation

Attention



As a step in safe parameterization of the PVED-CLS software, to ensure the correctness of the data in one or more modified sectors it shall be signed. Signing off correctness is understood as it has been verified that all values in a sector are correct. This is valid for the entire parameter sector.

The PVED-CLS software checks the sector data integrity (sector CRC) and if the sector data is approved (Signature CRC) as an instance of the power-up self-test. The PVED-CLS enters the safe state with a specific CAN diagnostic trouble code if one of the checks fail.

Important

- Two PSAC (Parameter Sector Approval Code) levels exists; OEM and Dealer.
- See Table 78 for which PSACs are valid for the sectors.
- The PSACs are fixed and cannot be changed for a given application software.
- Contact Danfoss Product Application Engineering for the relevant PSACs.
- It is the responsibility of the OEM/system integrator to keep the PSACs secret for unauthorized personnel.
- The PSACs shall be treated as confidential code and thus not displayed directly on a service tool page.
- Disclosing the PSACs may lead to loss of safety integrity of the product.



The data in a particular sector is approved by the following steps:

1. Verify the changes to the sector by comparison of desired data to read-back inverted data.
2. Calculate the signature CRC as CRC-CCITT (sector data + PSAC). See example.
3. Write signature CRC to signature CRC address (see).

The PSAC is a 4-character hex-string. The signature CRC is calculated by adding the PSAC data as if it was the last 4 bytes of the sector data.

Name	Address	Data type	Description of parameter
Hydraulic Config Signature	P40	U16	Signature CRC value for named sector
SEHS FDA Signature	P42		Signature CRC value for named sector
Valve Calibration Data Signature	P44		Signature CRC value for named sector
CAN WAS Calibration Data Signature	P46		Signature CRC value for named sector
Analogue Sensor Calibration Data Signature	P48		Signature CRC value for named sector
Peripherals Config Signature	P50		Signature CRC value for named sector
SEHS Protocol Data Signature	P52		Signature CRC value for named sector
Internal monitoring Signature	P54		Signature CRC value for named sector
Vehicle Geometry Signature	P56		Signature CRC value for named sector
GPS Config Signature	P58		Signature CRC value for named sector
STW Config Signature	P60		Signature CRC value for named sector
AUX Config Signature	P62		Signature CRC value for named sector

Table 80

17.5.5 Example

Example for calculating CRC signature for “Valve calibration data” (see section 17.5.2)

The serialized sector data is “5CFEA40197FF69001900”.

In this example PSAC = 12AFh is used. Note that this PSAC is not valid and will be detected as an incorrect PSAC by the PVED-CLS.

The signature CRC is calculated as the CRC-CCITT for “5CFEA40197FF69001900AF12”.

In this example, the Signature CRC turns out to be is 0xE0BD.

The low byte (BDh) shall be stored at P44 and the high byte (E0h) at P45

Important

Contact your local technical support at Danfoss Power Solutions for the correct PSAC values.



17.6 MANUAL CALIBRATION OF WAS, JOYSTICK AND SPOOL

17.6.1 Production/calibration flag

These counters will be updated automatically by the PLUS+1 Service Tool when using auto-calibration.

If manual calibration is being used or a service tool is designed for themselves, Danfoss encourages to use these counter to keep track of the number of calibrations.

The counters keeps track on how many times calibration has been carried out for CAN WAS, Analogue WAS, Analogue Joystick and the spool (when using auto-calibration).

Name	Address	Data type	Unit	Description of parameter	User	Range		Danfoss default value	Safety critical parameters 'S'
						Min.	Max.		
Calibration counter - Spool calibration	P3771	U8	-	Calibration counter - Spool calibration	OEM	0	255	0	
Bit inverted value for "Calibration counter - Spool calibration"	P3772	U8	-	Bit inverted value for "Calibration counter - Spool calibration"	OEM	0	255	255	
Calibration counter - Analogue WAS calibration	P3773	U8	-	Calibration counter - Analogue WAS	OEM	0	255	0	
Bit inverted value for "Calibration counter - Analogue WAS calibration"	P3774	U8	-	Bit inverted value for "Calibration counter - Analogue WAS"	OEM	0	255	255	
Calibration counter - CAN WAS calibration	P3775	U8	-	Calibration counter - CAN WAS	OEM	0	255	0	
Bit inverted value for "Calibration counter - CAN WAS calibration"	P3776	U8	-	Bit inverted value for "Calibration counter - CAN WAS"	OEM	0	255	255	
Calibration counter - Analogue joystick	P3777	U8	-	Analogue sensor based Joystick calibration counter	OEM	0	255	0	
Bit inverted value for "Calibration counter - Analogue joystick"	P3778	U8	-	Bit inverted value for Analogue sensor based Joystick calibration counter	OEM	0	255	255	

Table 81

17.6.2 Calibrating analogue wheel angle sensor

The following description explains how to manually calibrate analogue wheel angle sensors. The procedure consists of three main steps:

1. Read sensor values and sensor supply voltage
2. Data sector preparation
3. Write parameters to PVED-CLS' EEPROM

Procedure:

Read sensor values and sensor supply voltage

- Put PVED-CLS into "WAS calibration service mode"
- Start ADC readout on CAN bus
 - For MAIN- and SAFETY-controller, start status message 1 @ 100ms
 - For MAIN- and SAFETY-controller, start status message 3 @ 100ms
- Turn wheels into far left angle position
 - For MAIN- and SAFETY-controller, read AD1 and AD2 and temporarily store the two values
- Turn wheels into neutral/straight position
 - For MAIN- and SAFETY-controller, read AD1 and AD2 and temporarily store the two values
- Measure sensor supply voltage (only needed if the 5V Sensor supply compensation is enabled (P3217 set to 255 and P3219 set to 255))
- Turn wheels into far right angle position
 - For MAIN- and SAFETY-controller, read AD1 and AD2 and temporarily store the two values



Data sector preparation

- For MAIN- and SAFETY-controller, populate a temporary data sector for “Analogue Sensor Calibration data”. Use the temporarily stored values from “main step 1” for the displayed below, Analogue Sensor Calibration data

Name	Address	Data type	Unit	Description of parameter	User	Range		Danfoss default value	Safety critical parameters ‘S’
						Min.	Max.		
Primary analogue sensor max left position (Analogue)	P3205	U16	mVolts	Primary analogue sensor voltage output for leftmost position	OEM, Dealer	0	6000	500	
Primary analogue sensor max right position (Analogue)	P3207	U16	mVolts	Primary analogue sensor voltage output for rightmost position	OEM, Dealer	0	6000	4500	
Primary analogue sensor neutral position (Analogue)	P3209	U16	mVolts	Primary analogue sensor voltage output for neutral position	OEM, Dealer	0	6000	2500	
Redundant analogue sensor max left position (Analogue)	P3211	U16	mVolts	Redundant analogue sensor voltage output for leftmost position	OEM, Dealer	0	6000	500	
Redundant analogue sensor max right position (Analogue)	P3213	U16	mVolts	Redundant analogue sensor voltage output for rightmost position	OEM, Dealer	0	6000	4500	
Redundant analogue sensor neutral position (Analogue)	P3215	U16	mVolts	Redundant analogue sensor voltage output for neutral position	OEM, Dealer	0	6000	2500	
5V sensor supply for primary analogue sensor during calibration	P3217	U16	mVolts	Measured Supply voltage during calibration of the primary analogue sensor	OEM, Dealer	4650	5350	5000	
5V sensor supply for redundant analogue sensor during calibration	P3219	U16	mVolts	Measured Supply voltage during calibration of the redundant analogue sensor	OEM, Dealer	4650	5350	5000	
Automatically adjusted cylinder stroke volume (analogue WAS)	P3221	U16	ccm	Automatic adjusted cylinder stroke volume, for using analogue WAS, found during WAS auto-calibration	OEM, Dealer	100	65535	65535	
Automatically adjusted maximum steer angle to left side (analogue WAS)	P3223	U16	Deg	Automatic adjusted maximum steer angle to left side, for using analogue WAS, found during WAS auto-calibration	OEM, Dealer	0	65535	65535	
Automatically adjusted maximum steer angle to right side (analogue WAS)	P3225	U16	Deg	Automatic adjusted maximum steer angle to right side, for using analogue WAS, found during WAS auto-calibration	OEM, Dealer	0	65535	65535	

Table 82

- Calculate the sector CRC as CRC-16-CCITT (P3205...P3226) and store (word) at the CRC/Checksum address (P3235). For example of how to calculate sector CRC, please see paragraph 17.5.2.
- Furthermore, populate a temporary data sector for “Production/Calibration Flag”. Update the analogue WAS calibration counters. Increment P3773 from 0 to 1 and increment bit-wise inverted P3774 from 255 to 254 for the displayed below, Production/Calibration Flag

Name	Address	Data type	Unit	Description of parameter	User	Range		Danfoss default value	Safety critical parameters ‘S’
						Min.	Max.		
Calibration counter - Spool calibration	P3771	U8	-	Calibration counter - Spool calibration	OEM	0	255	0	
Bit inverted value for "Calibration counter - Spool calibration"	P3772	U8	-	Bit inverted value for "Calibration counter - Spool calibration"	OEM	0	255	255	
Calibration counter - Analogue WAS calibration	P3773	U8	-	Calibration counter - Analogue WAS	OEM	0	255	0	
Bit inverted value for "Calibration counter - Analogue WAS calibration"	P3774	U8	-	Bit inverted value for "Calibration counter - Analogue WAS"	OEM	0	255	255	
Calibration counter - CAN WAS calibration	P3775	U8	-	Calibration counter - CAN WAS	OEM	0	255	0	
Bit inverted value for "Calibration counter - CAN WAS calibration"	P3776	U8	-	Bit inverted value for "Calibration counter - CAN WAS"	OEM	0	255	255	
Calibration counter - Analogue joystick	P3777	U8	-	Analogue sensor based Joystick calibration counter	OEM	0	255	0	
Bit inverted value for "Calibration counter - Analogue joystick"	P3778	U8	-	Bit inverted value for Analogue sensor based Joystick calibration counter	OEM	0	255	255	

Table 83



- Calculate the sector CRC as CRC-16-CCITT (P3771...P3778) and store (word) at the CRC/Checksum address (P3789). For example of how to calculate sector CRC, please see paragraph 17.5.2.

Write parameters to PVED-CLS' EEPROM

- Put PVED-CLS into "bootloader mode"
- For MAIN-controller:
 - Write data sector "Analogue Sensor Calibration data"
 - Read back data (verification)
 - Acknowledge data correctness
 - To sign acknowledge, calculate signature CRC and write it at the CRC/signature address (P48)
 - Write data sector "Production/Calibration Flag"
- For SAFETY-controller:
 - Write data sector "Analogue Sensor Calibration data"
 - Read back data (verification)
 - Acknowledge data correctness
 - To sign acknowledge, calculate signature CRC and write it at the CRC/signature address (P48)
- Calculate the sector CRC as CRC-16-CCITT (P3771...P3778) and store (word) at the CRC/Checksum address (P3789). For example of how to calculate sector CRC, please see paragraph 17.5.2.

17.6.3 Calibrating CAN-based wheel angle sensor

The following description explains how to manually calibrate your CAN-based wheel angle sensor. The procedure consists of three main steps:

1. Read sensor values
2. Data sector preparation
3. Write parameters to PVED-CLS' EEPROM

The following is a more detailed description of each main step:

Read sensor values

- Put PVED-CLS into "WAS calibration service mode"
- Turn wheels into far left angle position
 - Read primary wheel angle via CAN message and temporarily store the value
 - Read secondary wheel angle via CAN message and temporarily store the value
- Turn wheels into neutral/straight position
 - Read primary wheel angle via CAN message and temporarily store the value
 - Read secondary wheel angle via CAN message and temporarily store the value
- Turn wheels into far right angle position
 - Read primary wheel angle via CAN message and temporarily store the value
 - Read secondary wheel angle via CAN message and temporarily store the value

Data sector preparation



- For MAIN- and SAFETY-controller, populate a temporary data sector for “CAN WAS Calibration data”. Use the temporarily stored values from “main step 1” for the displayed below, CAN WAS Calibration data

Name	Address	Data type	Unit	Description of parameter	User	Range		Danfoss default value	Safety critical parameters ‘S’
						Min.	Max.		
WAS max left position (CAN)	P3185	U16	mVolts	Wheel angle sensor voltage output for leftmost position over CAN	OEM, Dealer	0	5000	500	
WAS max right position (CAN)	P3187	U16	mVolts	Wheel angle sensor voltage output for rightmost position over CAN	OEM, Dealer	0	5000	4500	
WAS neutral position (CAN)	P3189	U16	mVolts	Wheel angle sensor voltage output for neutral position over CAN	OEM, Dealer	0	5000	2500	
Automatically adjusted cylinder stroke volume (CAN WAS)	P3191	U16	ccm	Automatic adjusted cylinder stroke volume, for using CAN WAS, found during WAS auto-calibration	OEM, Dealer	100	65535	65535	
Automatically adjusted maximum steer angle to left side (CAN WAS)	P3193	U16	Deg	Automatic adjusted maximum steer angle to left side, for using CAN WAS, found during WAS auto-calibration	OEM, Dealer	0	65535	65535	
Automatically adjusted maximum steer angle to right side (CAN WAS)	P3195	U16	Deg	Automatic adjusted maximum steer angle to right side, for using CAN WAS, found during WAS auto-calibration	OEM, Dealer	0	65535	65535	

Table 84

- Calculate the sector CRC as CRC-16-CCITT(P3185...P3196) and store (word) at the CRC/Checksum address (P3203). For example of how to calculate sector CRC, please see paragraph 17.5.2.
- Furthermore, populate a temporary data sector for “Production/Calibration Flag”. Update the CAN based WAS calibration counters. Increment P3775 from 0 to 1 and increment bit-wise inverted P3776 from 255 to 254 for the displayed below, Production/Calibration Flag

Name	Address	Data type	Unit	Description of parameter	User	Range		Danfoss default value	Safety critical parameters ‘S’
						Min.	Max.		
Calibration counter - Spool calibration	P3771	U8	-	Calibration counter - Spool calibration	OEM	0	255	0	
Bit inverted value for "Calibration counter - Spool calibration"	P3772	U8	-	Bit inverted value for "Calibration counter - Spool calibration"	OEM	0	255	255	
Calibration counter - Analogue WAS calibration	P3773	U8	-	Calibration counter - Analogue WAS	OEM	0	255	0	
Bit inverted value for "Calibration counter - Analogue WAS calibration"	P3774	U8	-	Bit inverted value for "Calibration counter - Analogue WAS"	OEM	0	255	255	
Calibration counter - CAN WAS calibration	P3775	U8	-	Calibration counter - CAN WAS	OEM	0	255	0	
Bit inverted value for "Calibration counter - CAN WAS calibration"	P3776	U8	-	Bit inverted value for "Calibration counter - CAN WAS"	OEM	0	255	255	
Calibration counter - Analogue joystick	P3777	U8	-	Analogue sensor based Joystick calibration counter	OEM	0	255	0	
Bit inverted value for "Calibration counter - Analogue joystick"	P3778	U8	-	Bit inverted value for Analogue sensor based Joystick calibration counter	OEM	0	255	255	

Table 85



- Calculate the sector CRC as CRC-16-CCITT (P3771...P3778) and store (word) at the CRC/Checksum address (P3789). For example of how to calculate sector CRC, please see paragraph 17.5.2

Write parameters to PVED-CLS' EEPROM

- Put PVED-CLS into "bootloader mode"
- For MAIN-controller:
 - Write data sector "CAN WAS Calibration data"
 - Read back data (verification)
 - Acknowledge data correctness
 - To sign acknowledge, calculate signature CRC and write it at the CRC/signature address (P46)
 - Write data sector "Production/Calibration Flag"
- For SAFETY-controller:
 - Write data sector "CAN WAS Calibration data"
 - Read back data (verification)
 - Acknowledge data correctness
 - To sign acknowledge, calculate signature CRC and write it at the CRC/signature address (P46)

17.6.4 Calibrating Analogue Joystick

The following description explains how to manually calibrate Analogue Joystick. The procedure consists of three main steps:

1. Read sensor values and sensor supply voltage
2. Data sector preparation
3. Write parameters to PVED-CLS' EEPROM

Procedure:

Read sensor values and sensor supply voltage

- Put PVED-CLS into "Joystick Calibration service mode"
- Start ADC readout on CAN bus
 - For MAIN- and SAFETY-controller, start status message 1 @ 100ms
 - For MAIN- and SAFETY-controller, start status message 3 @ 100ms
- Turn Joystick to left most position
 - For MAIN- and SAFETY-controller, read AD1 and AD2 and temporarily store the two values
- Turn Joystick to neutral position
 - For MAIN- and SAFETY-controller, read AD1 and AD2 and temporarily store the two values
- Measure sensor supply voltage (only needed if the 5V Sensor supply compensation is enabled (P3217 set to 255 and P3219 set to 255))
- Turn Joystick to right most position
 - For MAIN- and SAFETY-controller, read AD1 and AD2 and temporarily store the two values



Data sector preparation

- For MAIN- and SAFETY-controller, populate a temporary data sector for “Analogue Sensor Calibration data”. Use the temporarily stored values from “main step 1” for the displayed below, Analogue Sensor Calibration data

Name	Address	Data type	Unit	Description of parameter	User	Range		Danfoss default value	Safety critical parameters ‘S’
						Min.	Max.		
Primary analogue sensor max left position (Analogue)	P3205	U16	mVolts	Primary analogue sensor voltage output for leftmost position	OEM, Dealer	0	6000	500	
Primary analogue sensor max right position (Analogue)	P3207	U16	mVolts	Primary analogue sensor voltage output for rightmost position	OEM, Dealer	0	6000	4500	
Primary analogue sensor neutral position (Analogue)	P3209	U16	mVolts	Primary analogue sensor voltage output for neutral position	OEM, Dealer	0	6000	2500	
Redundant analogue sensor max left position (Analogue)	P3211	U16	mVolts	Redundant analogue sensor voltage output for leftmost position	OEM, Dealer	0	6000	500	
Redundant analogue sensor max right position (Analogue)	P3213	U16	mVolts	Redundant analogue sensor voltage output for rightmost position	OEM, Dealer	0	6000	4500	
Redundant analogue sensor neutral position (Analogue)	P3215	U16	mVolts	Redundant analogue sensor voltage output for neutral position	OEM, Dealer	0	6000	2500	
5V sensor supply for primary analogue sensor during calibration	P3217	U16	mVolts	Measured Supply voltage during calibration of the primary analogue sensor	OEM, Dealer	4650	5350	5000	
5V sensor supply for redundant analogue sensor during calibration	P3219	U16	mVolts	Measured Supply voltage during calibration of the redundant analogue sensor	OEM, Dealer	4650	5350	5000	
Automatically adjusted cylinder stroke volume (analogue WAS)	P3221	U16	ccm	Automatic adjusted cylinder stroke volume, for using analogue WAS, found during WAS auto-calibration	OEM, Dealer	100	65535	65535	
Automatically adjusted maximum steer angle to left side (analogue WAS)	P3223	U16	Deg	Automatic adjusted maximum steer angle to left side, for using analogue WAS, found during WAS auto-calibration	OEM, Dealer	0	65535	65535	
Automatically adjusted maximum steer angle to right side (analogue WAS)	P3225	U16	Deg	Automatic adjusted maximum steer angle to right side, for using analogue WAS, found during WAS auto-calibration	OEM, Dealer	0	65535	65535	

Table 86

- Calculate the sector CRC as CRC-16-CCITT (P3205...P3226) and store (word) at the CRC/Checksum address (P3235). For example of how to calculate sector CRC, please see paragraph 17.5.2.
- Furthermore, populate a temporary data sector for “Production/Calibration Flag”. Update the analogue joystick calibration counters. Increment P3777 from 0 to 1 and increment bit-wise inverted P3778 from 255 to 254 for the displayed below,

Production/Calibration Flag

Name	Address	Data type	Unit	Description of parameter	User	Range		Danfoss default value	Safety critical parameters ‘S’
						Min.	Max.		
Calibration counter - Spool calibration	P3771	U8	-	Calibration counter - Spool calibration	OEM	0	255	0	
Bit inverted value for "Calibration counter - Spool calibration"	P3772	U8	-	Bit inverted value for "Calibration counter - Spool calibration"	OEM	0	255	255	
Calibration counter - Analogue WAS calibration	P3773	U8	-	Calibration counter - Analogue WAS	OEM	0	255	0	
Bit inverted value for "Calibration counter - Analogue WAS calibration"	P3774	U8	-	Bit inverted value for "Calibration counter - Analogue WAS"	OEM	0	255	255	
Calibration counter - CAN WAS calibration	P3775	U8	-	Calibration counter - CAN WAS	OEM	0	255	0	
Bit inverted value for "Calibration counter - CAN WAS calibration"	P3776	U8	-	Bit inverted value for "Calibration counter - CAN WAS"	OEM	0	255	255	
Calibration counter - Analogue joystick	P3777	U8	-	Analogue sensor based Joystick calibration counter	OEM	0	255	0	
Bit inverted value for "Calibration counter - Analogue joystick"	P3778	U8	-	Bit inverted value for Analogue sensor based Joystick calibration counter	OEM	0	255	255	

Table 87

- Calculate the sector CRC as CRC-16-CCITT (P3771...P3778) and store (word) at the CRC/Checksum address (P3789). For example of how to calculate sector CRC, please see paragraph 17.5.2.

Write parameters to PVED-CLS' EEPROM

- Put PVED-CLS into "bootloader mode"
- For MAIN-controller:
 - Write data sector "Analogue Sensor Calibration data"
 - Read back data (verification)
 - Acknowledge data correctness
 - To sign acknowledge, calculate signature CRC and write it at the CRC/signature address (P48)
 - Write data sector "Production/Calibration Flag"
- For SAFETY-controller:
 - Write data sector "Analogue Sensor Calibration data"
 - Read back data (verification)
 - Acknowledge data correctness
 - To sign acknowledge, calculate signature CRC and write it at the CRC/signature address (P48)

Calculate the sector CRC as CRC-16-CCITT (P3771...P3778) and store (word) at the CRC/Checksum address (P3789). For example of how to calculate sector CRC, please see paragraph 17.5.2.

17.6.5 Manual spool calibration

17.6.5.1 Spool calibration overview

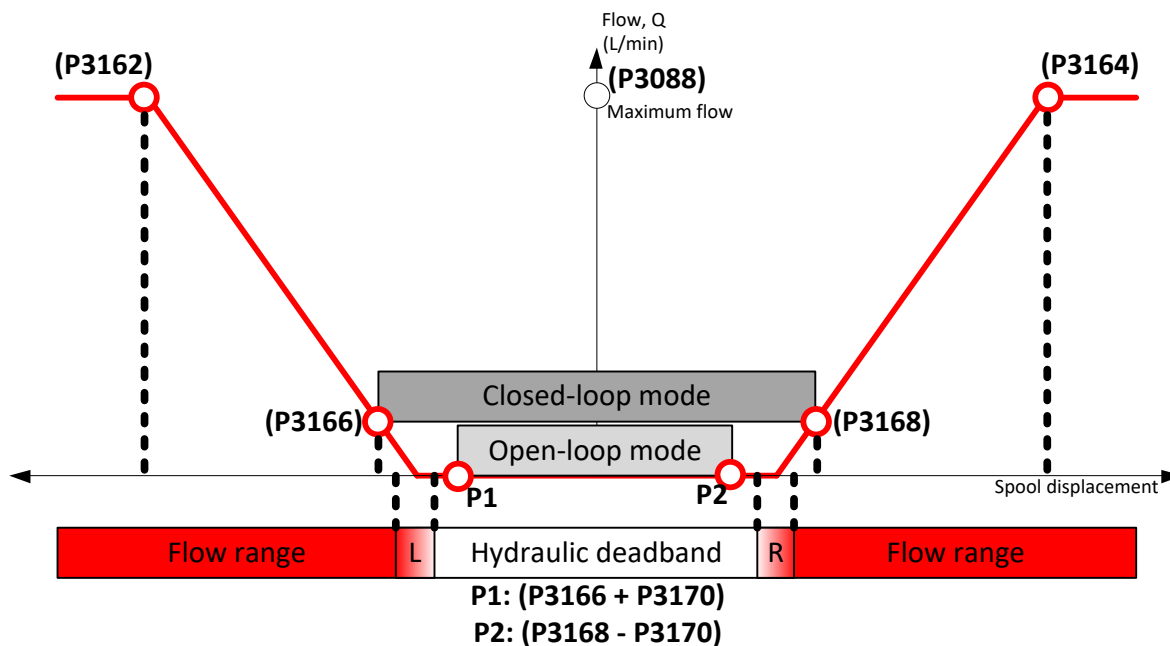

Figure 68

P3162 and P3164 define the maximum spool stroke and are set to the stroke length where the spool is mechanically stopped by the valve.

P3166 and P3168 define the closed-loop dead-band spool positions known to the software.

Parameter P3170 is a spool position offset, which is added/subtracted (P1 and P2) to the spool position set-points in open loop only.



Name	Address	Data type	Unit	Description of parameter	User	Range		Danfoss default value	Safety critical parameters 'S'
						Min.	Max.		
Max spool position, left	P3162	S16	x10u Meter	Spool left most position	OEM, Dealer	-1000	-300	-420	
Max spool position, right	P3164	S16	x10u Meter	Spool right most position	OEM, Dealer	300	1000	420	
Closed loop dead-band edge, left	P3166	S16	x10u Meter	Spool closed loop dead-band edge, Left	OEM, Dealer	-300	0	-105	
Closed loop dead-band edge, right	P3168	S16	x10u Meter	Spool closed loop dead-band edge, Right	OEM, Dealer	0	300	105	
Open loop dead-band edge offset	P3170	S16	x10u Meter	Spool open loop dead-band offset	OEM, Dealer	0	150	25	

Table 88

17.6.5.2 Spool calibration procedure

17.6.5.2.1 Determining the closed loop dead-bands

The principle in this calibration procedure is to determine the closed-loop mode dead-bands first. The closed-loop dead-bands are defined as the slowest possible steered wheel movement speed that is used for controlling the smallest possible wheel angle position error (proportional control). Once the closed-loop dead-bands are determined (P3166 and P3168), the open-loop dead-bands are derived by subtracting an off-set (P3170) from the respective closed-loop mode dead-band positions (P1 and P2 from Figure 68)

The following calibration procedure is based on balancing the time it takes to move between two fixed wheel angles by adjusting two experimental spool position set-point values.

Important

The criteria which shall be evaluated for valve calibration are:

- The times to move from left to right and vice versa are equal (symmetry measure)
- The time to move from left to right and vice versa is sufficiently slow (minimum flow)

These above times depends on e.g. vehicle geometry, steering type, cylinder stroke volume, wheel angle sensor calibration, valve capacity and requirements on minimum correction flows for closed-loop mode operation.

17.6.5.2.2 Determining the open loop dead-bands

When the closed-loop mode dead-bands are found, the open-loop dead-bands values (P1 and P2 from Figure 68) are set by subtracting an offset (defined by parameter P3170) from the closed-loop dead-band values.

The criteria for having derived good open-loop dead-bands are:

- The valve shall not steer out any flow and therefore the steered wheel shall not exhibit movement jitter when no steering activity takes place

17.6.5.2.3 Calibration procedure

The following steps describes a calibration procedure, which can be obtained or could be implemented in a service tool. Refer Figure 69 for below steps.

1. The calibration operator inputs two initial experimental main spool set-points **S1** and **S2** which the calibration algorithm alternates between.
2. The starting point for the measurement is when the steered wheel angle is at Calib_WA_L.
3. The calibration algorithm applies main spool set-point **S1** to initiate a steering direction towards right.
4. The time **T1** it takes for the steered wheels to reach Calib_WA_R is measured and denoted **TR**.
5. When the steered wheels reaches Calib_WA_R, the calibration algorithm applies main spool set-point **S2** to initiate a steering direction towards left.
6. The time **T2** it takes for the steered wheels to reach Calib_WA_L is measured and denoted **TL**.
7. The calibration operator continuously evaluates **TR** and **TL** and stepwise increases or decreases the spool set-points **S1** and **S2**.
8. Repeat from step 3 until **TR** and **TL** meets the success criteria described in section 17.6.5.2 and shown as **T3** and **T4**).

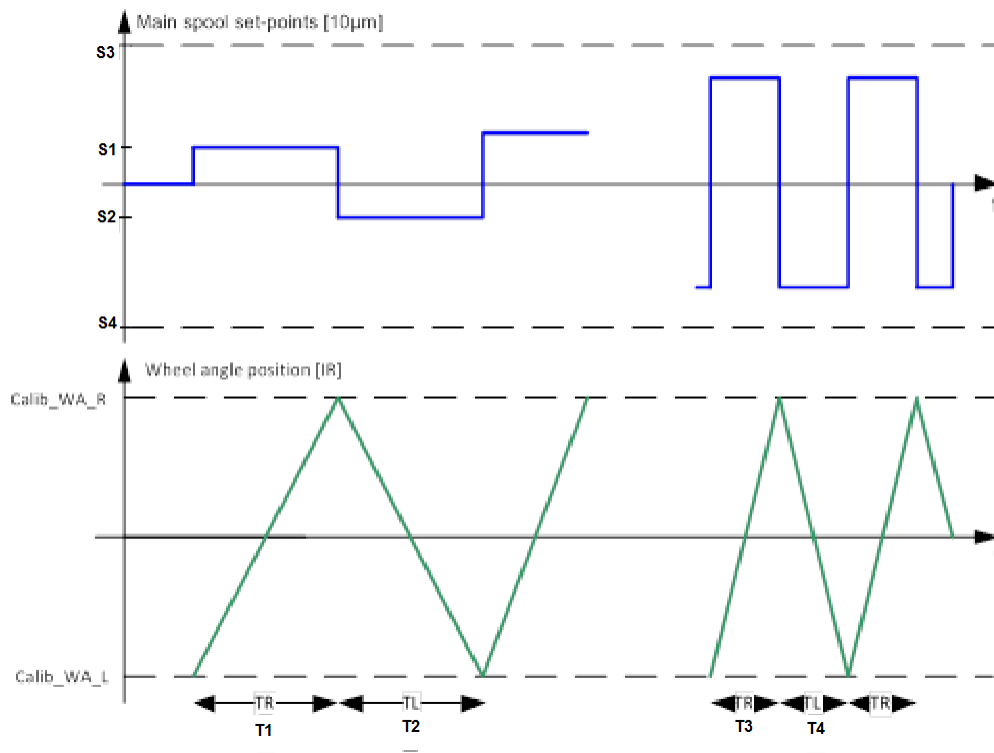

Figure 69



17.6.5.2.4 Closed loop dead-band calibration

Figure 770 shows a possible implementation of the calibration procedure and the associated functions which shall be performed by the calibration tool.

The PVED-CLS shall be put in “Service mode – direct output control”. Two initial test spool position set-points (test_db_R and test_db_L) shall be used. The calibration procedure will first initialize the steered wheels to the wheel angle given by Calib_WA_R.

After this step, the steered wheels will attempt to steer between the wheel angles given by Calib_WA_R and Calib_WA_L. The time it takes from one side to the other is measured and stored in TR and TL.

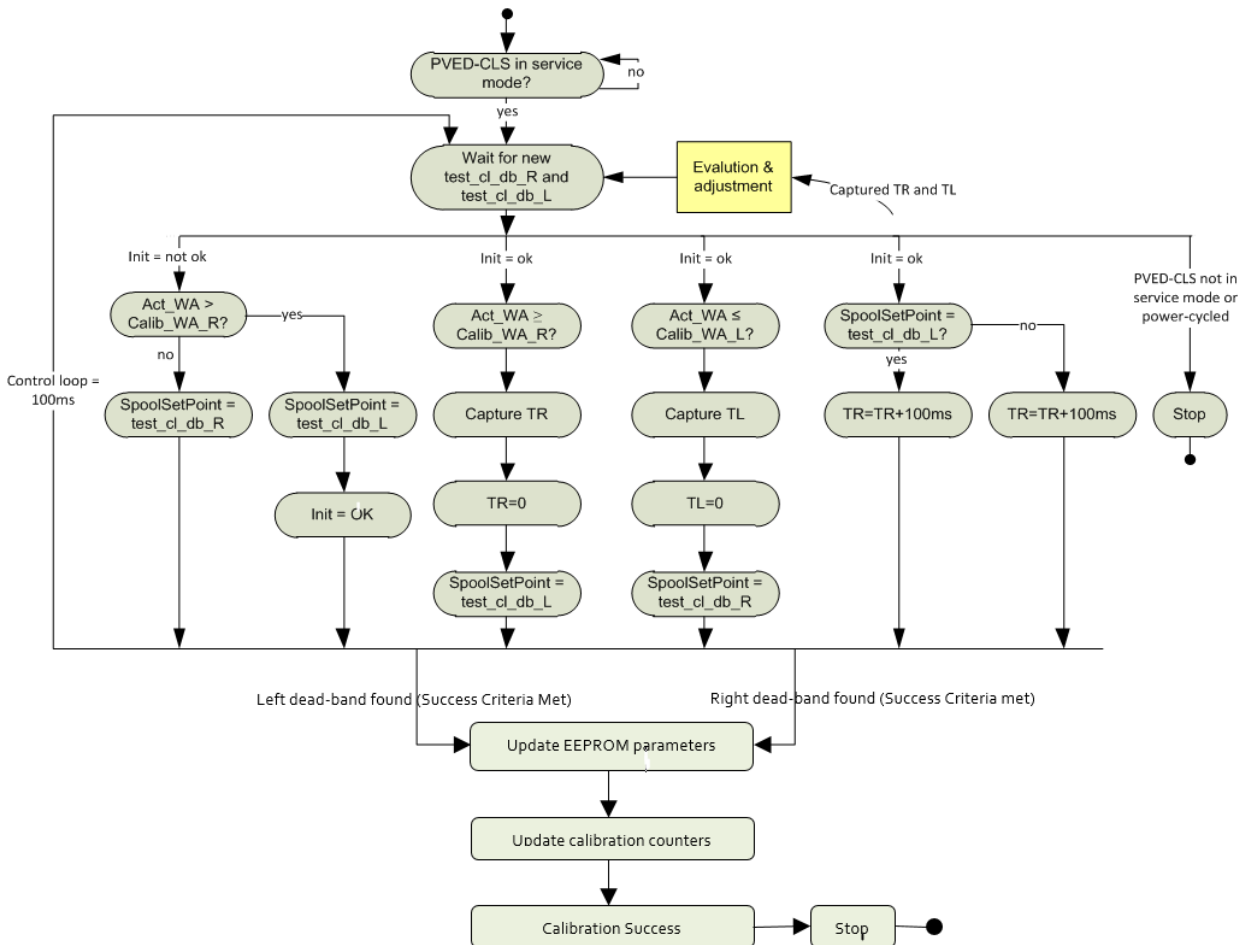

Figure 70

While the calibration algorithm is executed, the calibration tool shall continuously capture TR and TL and individually evaluate these values against the success criteria. The calibration tool shall individually adjust test_db_R and test_db_L until the calibration success criteria is met. When success criteria are met the closed-loop dead-band can directly be derived as follows:

test_db_L =	test_cl_db_L =	P3166
test_db_R =	test_cl_db_R =	P3168

Table 89



17.6.5.2.5 Open loop dead-band calibration

As illustrated in Table 90, the open loop dead-bands are the previously found closed loop dead-bands, P3166 and P3168, added or subtracted by the offset value determined by P3170, respectively. After the closed loop dead-band are found, check if the default (P3170 = 25) satisfies the open-loop dead-band criteria (no output flow when the spool is positioned in the open-loop dead-band e.g. verify by direct output control-function to test these parameters. Do it across a small population to gain confidence in the offset). If the wheels are still moving, increase P3170 by 5 and do the verification again. Repeat until acceptance criteria has been fulfilled.

The open-loop dead-bands are directly derived from the measured closed-loop dead-bands as follows:

P1 from Figure	Spool open-loop dead-band left =	Test_cl_db_L + P3170	P3166 + P3170
P2 from Figure	Spool open-loop dead-band right =	Test_cl_db_R - P3170	P3168 - P3170

Table 90

17.6.5.2.6 Determining TL and TR for a specific vehicle type

When determining the success criteria for a specific vehicle type, the goal is to determine target TR and TL values through a learning phase that can subsequently be used for multiple vehicles of the same type.

For learning TR and TL for a specific vehicle, the following should be considered:

1. For a given test_db_L/R, observe that the steered wheels move very slowly and continuously.
2. Use the calibration procedure in Figure 7 to determine TR and TL.
3. Fine-tune test_db_L and test_db_R until TR and TL are identical

The values TR and TL should now be used as target set-points for subsequent valve calibration for this specific type of vehicle.



17.6.5.3 Post conditions

After a successful manual spool calibration, the calibration counter and bit inverted copy for spool calibration should be updated as described below:

- Populate a temporary data sector for “Production/Calibration Flag”. Update the Spool dead-band calibration counters. Increment P3771 from 0 to 1 and increment bit-wise inverted P3772 from 255 to 254 for the displayed below,
Production/Calibration Flag

Name	Address	Data type	Unit	Description of parameter	User	Range		Danfoss default value	Safety critical parameters ‘S’
						Min.	Max.		
Calibration counter - Spool calibration	P3771	U8	-	Calibration counter - Spool calibration	OEM	0	255	0	
Bit inverted value for "Calibration counter - Spool calibration"	P3772	U8	-	Bit inverted value for "Calibration counter - Spool calibration"	OEM	0	255	255	
Calibration counter - Analogue WAS calibration	P3773	U8	-	Calibration counter - Analogue WAS	OEM	0	255	0	
Bit inverted value for "Calibration counter - Analogue WAS calibration"	P3774	U8	-	Bit inverted value for "Calibration counter - Analogue WAS"	OEM	0	255	255	
Calibration counter - CAN WAS calibration	P3775	U8	-	Calibration counter - CAN WAS	OEM	0	255	0	
Bit inverted value for "Calibration counter - CAN WAS calibration"	P3776	U8	-	Bit inverted value for "Calibration counter - CAN WAS"	OEM	0	255	255	
Calibration counter - Analogue joystick	P3777	U8	-	Analogue sensor based Joystick calibration counter	OEM	0	255	0	
Bit inverted value for "Calibration counter - Analogue joystick"	P3778	U8	-	Bit inverted value for Analogue sensor based Joystick calibration counter	OEM	0	255	255	

Table 91

- Calculate the sector CRC as CRC-16-CCITT (P3771...P3778) and store (word) at the CRC/Checksum address (P3789). For example of how to calculate sector CRC, please see paragraph 17.5.2
- Write data sector “Production/Calibration Flag” to the MAIN-controller

