

Data Sheet

PLUS+1[®] Controllers

MC024-130 and MC024-132



Mobile machine management

These general purpose modular housings, connectors, and control circuitry are designed as flexible, expandable, powerful, cost effective standalone modules for smaller machined systems or as total machine management systems with intelligence in every node. These modules communicate with one another and other intelligent systems over a machine Controller Area Network (CAN) data bus.



Product highlights

The MC024-130 employs a 32 bit Cortex-M3 Processor, providing the controller with extremely fast single cycle processing speed and 512K internal flash. The MC024-132 has an application key that enables the use of Danfoss developed GUIDE machine control solutions. The same GUIDE HWD file is used with both controllers.

Application development

PLUS+1[®] hardware modules have input or output pins that support multiple functions. Pins that support multiple input or output types are user-configurable using PLUS+1[®] GUIDE software. This Microsoft[®] Windows[®] based development environment features a user-friendly, field proven, icon-based graphical programming tool, application downloader, and service/diagnostic tool.

Features

- User-programmable with PLUS+1[®] GUIDE (Graphical User Integrated Development Environment)
- 24 pins: (2) individually keyed DEUTSCH DTM12 pin connectors
- ARM 32 bit Cortex-M3 running at 120 MHz
- 12 bit analog-to-digital converter
- 16 bit timers/counters
- FRAM non-volatile memory
- 9 to 36 Vdc power supply, monitored internally
- 2 CAN 2.0 B ports, the fixed range analog input can be configured as the shield pin
- Power supply for external sensors rated at 5Vdc to 200 mA and regulated internally
- 2 LEDs under user control
- 3 mounting alternatives: stack, end, or side
- MC024-132 contains application key required to run Danfoss developed machine control application software
- CE compliant

6 inputs

- (5) universal (DIN/AIN/FreqIN) that are user-defined as either:
 - Analog: with configurable ranges 0 to 5.25 Vdc (with over range protection) or 0 to 36 Vdc
 - Digital: pull up (5 Vdc), pull down (0 Vdc) or pull to center (2.5 Vdc)
 - Frequency (timing): 1 Hz to 10 kHz
- (1) fixed range analog (AIN/CAN shield) 0 to 5.25 Vdc or CAN shield pin

8 outputs

- (8) universal (PWMOUT/DOOUT/PVGOUT) that are user-defined as either:
 - Digital: (3 A), configurable as source or sink
 - PWM: (30 to 4000 Hz), configurable as open or closed loop with current control
 - Analog voltage: open loop PWM at 4000 Hz
- Any PWMOUT/DOOUT/PVGOUT can be used to provide reference power to one PVG valve

Data Sheet
MC024-130 and 132 Controllers

Dimensions

mm [in]

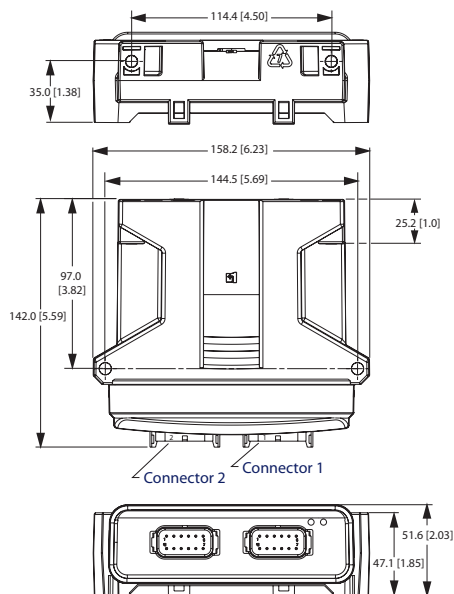

! Caution

PCB damage may occur. All device power supply + pins must be connected to battery +.
 This device is not field serviceable. Opening the device housing will void the warranty.

Technical specifications

Supply voltage	9 to 36 Vdc
Operating temperature (ambient)	-40°C to 70°C [-40°F to 158°F]
Storage temperature	-40°C to 85°C [-40°F to 185°F]
Programming temperature	-40°C to 70°C [-40°F to 158°F]
IP rating (with mating connector attached)	IP 67
EMI/RFI rating	100 V/m
Weight	0.40 kg [0.88 lb]
Vibration	IEC 60068-2-64
Shock	IEC 60068-2-27 test Ea
Maximum current, sourcing	24 A
Maximum current, sinking	8 A

CG150 CAN/USB Gateway	10104136	
DEUTSCH mating connector bag assembly	10102023 (16 to 20 AWG)	10100945 (20 to 24 AWG)
PLUS+1[®] GUIDE single user license	10101000	

Ordering information

MC024-130	11144803
MC024-132	11144804

Pin information

24 pin connector

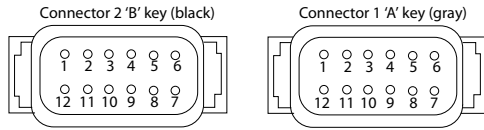

Connector 2

Pin	Controller function
C2-P1	DIN/AIN/FreqIN
C2-P2	DIN/AIN/FreqIN
C2-P3	PWMOUT/DOOUT/PVGOUT
C2-P4	PWMOUT/DOOUT/PVGOUT
C2-P5	PWMOUT/DOOUT/PVGOUT
C2-P6	PWMOUT/DOOUT/PVGOUT
C2-P7	PWMOUT/DOOUT/PVGOUT
C2-P8	PWMOUT/DOOUT/PVGOUT
C2-P9	PWMOUT/DOOUT/PVGOUT
C2-P10	PWMOUT/DOOUT/PVGOUT
C2-P11	Power supply +
C2-P12	Power supply +

Connector 1

Pin	Controller function
C1-P1	Power ground -
C1-P2	Power supply +
C1-P3	CAN0 +
C1-P4	CAN0 -
C1-P5	AIN/CAN shield
C1-P6	CAN1 +
C1-P7	CAN1 -
C1-P8	5 Vdc sensor power +
C1-P9	Sensor power ground -
C1-P10	DIN/AIN/FreqIN
C1-P11	DIN/AIN/FreqIN
C1-P12	DIN/AIN/FreqIN

Comprehensive technical literature is online at www.danfoss.com