

ENGINEERING
TOMORROW

Danfoss

User Guide

Intelligent Purging System (IPS 8) Ammonia

Info for UK customers only
Danfoss Ltd, Oxford Road, UB9
4LH Denham, UK

230 V AC, 50 Hz. CE marked



Other IPS 8 User Guide languages

Contents	Legal notice.....	3
	Technical data.....	4
	Ordering.....	4
	Introduction.....	5
	Features.....	5
	Working principle.....	6
	Working cycle.....	7
	Air traps.....	8
	Connection locations.....	9
	Connection points.....	11
	Installation.....	12
	Electrical wiring.....	14
	Light Indicators.....	16
	Quick Startup.....	17
	General display.....	17
	Configuring using the LCD.....	18
	Modbus RTU.....	20
	Maintenance/Service/Disposal.....	27

Legal notice

This product information is a part of the documentation for the Danfoss scope of delivery and serves as product presentation and customer advisory service. It contains important information and technical data regarding the product.



This product information should be supplemented with the information about the industrial safety and health related regulations at the site of installation of the product. The regulations vary from place to place as a result of the statutory regulations applicable at the site of installation and are therefore not considered in this product information.

In addition to this product information and the accident prevention regulations applicable for the respective country and area where the product is used, the technical regulations for safe and professional work must also be observed.

This product information has been written in good faith. However, Danfoss cannot be held responsible for any errors that this document may contain or for their consequences.

Danfoss reserves the right to make technical changes during the course of further development of the equipment covered by this product information.

Illustrations and drawings in this product information are simplified representations. As a result of the improvements and changes, it is possible that the illustrations do not exactly match the current development status. The technical data and dimensions are subject to change. No claims will be accepted on the basis of them.

Danfoss A/S
 6430 Nordborg
 Denmark
 CVR nr.: 20 16 57 15
 Telephone: +45 7488 2222
 Fax: +45 7449 0949

EU DECLARATION OF CONFORMITY

Danfoss A/S

Refrigeration & Air Conditioning Controls

declares under our sole responsibility that the

Product category: Intelligent Purger System (Air Purger)

Type designation(s): IPS 8

Covered by this declaration is in conformity with the following directive(s), standard(s) or other normative document(s), provided that the product is used in accordance with our instructions.

Machine Directive 2006/42/EC
 EN 378-2:2016 Refrigerating systems and heat pumps - Safety and environmental requirements - Part 2: Design, construction, testing, marking and documentation

IEC 60204-1:2018 Safety requirements for electrical equipment for measurement, control and laboratory use - Part 1: General requirements

Pressure Equipment Directive 2014/68/EU (PED)
 EN 378-2:2016 Refrigerating systems and heat pumps - Safety and environmental requirements - Part 2: Design, construction, testing, marking and documentation

Ammonia side (R717): Category A4P3. Fluid group: 1. PS = 40 bar. TS: -40 °C to 60 °C
 R452A side: Category 1. Fluid group: 2. PS = 28 bar. TS: -40 °C to 60 °C

Ambient temperature: -10 °C to 43 °C

Electromagnetic Compatibility Directive 2014/30/EU (EMC)
 IEC 61000-6-2 Electromagnetic compatibility (EMC) - Part 6-2: Generic standards - Immunity standard for industrial environments (IEC77/488/CDV:2015)

EN 61000-6-4 Electromagnetic compatibility (EMC) - Part 6-4: Generic standards - Emission standard for industrial environments

Note: EMC test performed with cable length < 30m.

Date: YYYYMMDD Place of issue:	Issued by Signature: Name: Su Cheong Ho Title: Lead Design Engineer	Date: YYYYMMDD Place of issue:	Approved by Signature: Name: Behzad Parastar Title: Product Manager
-----------------------------------	-------------------------------------------------------------------------------------------------------	-----------------------------------	-------------------------------------------------------------------------------------------------------

Danfoss only vouches for the correctness of the English version of this declaration. In the event of the declaration being translated into any other language, the translator concerned shall be liable for the correctness of the translation

ID No: 084R9456
This doc. is managed by 500B0577
Revision No: AA
Page 1 of 1

Technical data

Supply voltage	230V AC, 1 ph, 50Hz
Current	5.7 A (max. 6.5 A)
Power consumption	max. 1.3 kW
Short-circuit current rating	Icc 10kA
Temperature range ambient	-10 °C to +43 °C (14 °F to 109 °F)
Temperature range transport/storage	-30 °C to +60 °C (-22 °F to 140 °F)
Enclosure	IP55
Weight	max. 100 kg (221 lbs)
Dimensions (LxWxH)	1051 x 441 x 703 mm (41.4 x 17.4 x 27.7 inches)
Purger refrigerant	R452A 900 gram (31.7 oz)
Max. operating pressure (PS) R452A	28 bar (406 psi)
System refrigerant	R717
Min. operating pressure R717	6.5 bar (94 psi)
Max. operating pressure R717	40 bar (580 psi)
Operating temperature R717	-40 °C to +60 °C (-40 °F to 140 °F)

Ordering

Unit	Code number
Danfoss Intelligent Purging System IPS 8 unit	084H5001

Accessories/Spare parts	Accessory	Spare part	Code
Flange blind blank incl Bolts, nuts and Gaskets*	x		084H5053
SV3 Float Valve	x		027B2023
ICF 15-4 solenoid, DIN Butt weld 15mm ½ inch	x		027L4543
ICF 15-4 solenoid, ANSI Socket weld 15mm ½ inch	x		027L4538
ICF 15-4 solenoid, ANSI Butt weld 15mm ½ inch	x		027L4602
Welding Flange incl Bolts, nuts and Gaskets		x	084H5055
Purger solenoid kit (Armature, tube, Sealing, Orifice, Filter insert)		x	084H5051
Solenoid coil, 220 – 230V, 50 HZ for AKV	x		018F6801
Solenoid coil, 24V DC for AKV	x	x	018F6757
PSU, 24V DC - optional for powering purge points	x	x	080Z0055
Restrictor, purge line		x	084H5054
Compressor Cranck case heater		x	084H5058
Condenser coil assy incl screws		x	084H5059
Fan motor for condenser Incl fan grid and screws		x	084H5060
Extraction Fan		x	084H5056
Air grid with filter (2 pieces)		x	084H5057
Pre-programmed MCX 15		x	084H5052
Pressure transmitter evaporator, soldered (AKS 32R)		x	060G3552
Compressor including Start relay box and Start and Run Capacitor		x	123B2126
Compressor Hi-temp sensor		x	084N2003
Expansion valve, R452A		x	068U3881
Sight glass		x	014-0191
Pressure transmitter - R717, Threaded, AKS2050		x	060G5750
Thermostat for crankcase heater control		x	060L111166
Temperature sensor - R717, AKS 21M		x	084N2003
Pressure switch for Fan		x	Contact Danfoss
Pressure safety switch		x	Contact Danfoss

* For closing system flange during system pressure testing

Note:

All Spare part items are parts already built into the IPS 8. All accessories are not.

Introduction

The Danfoss Intelligent Purging System (IPS 8) is a stand-alone, self-contained purging unit designed to remove non-condensable gases (NC gases = air and other unwanted foreign gases) from industrial ammonia refrigeration systems.

The IPS control can handle up to 8 purge points automatically.

The ingress of NC gases into a refrigeration system is inevitable, regardless of the refrigerant pressures, or temperatures. NC gases in the system will result in a decrease in system efficiency, both in terms of an increase in power consumption and reduced cooling capacity.

Due to having a different density than ammonia, the ingressed air will accumulate in specific areas of the system, where it can be removed using the Danfoss IPS 8.

The accumulation areas are identified in the Connection locations section, along with recommended connection principles.

The purger unit is an electronically controlled, self-contained R452A refrigerant system that runs

independent of the main ammonia system and with only one flange connection to the ammonia plant.

The flanged opening allows the ammonia gas/NC gas mix access to the purger's heat exchanger, where it is split into ammonia condensate and NC gases. The ammonia condensate is returned by gravity to the main plant, while the NC gases are purged to the atmosphere through e.g. a water bath.

Through the flanged opening, the purger unit has access to the parameters from the ammonia plant required for full electronic control.

The unit runs automatically in 24-hour cycles, checking for the presence of NC gases and, if present, removes the NC gases.

To regain and retain the design capacity of the main ammonia system and prevent future air accumulation, it is highly recommended to install the Danfoss IPS 8.

Features

- State-of-the-art electronically controlled unit based on the Danfoss MCX controller platform
- Reduced power consumption of the ammonia plant
- Automatic purging response to NC gases in the refrigeration system
- Continuous and smart monitoring of differential pressure between the system refrigerant and the purger's refrigerant
- Smart purging that minimizes refrigerant (ammonia) release to the environment
- Self-contained unit operation, which functions independently from the main plant
- An operation log for easy purging cycle data monitoring
- Industry standard Modbus RTU communication for remote monitoring and system integration
- Reduced purging unit power consumption compared to other units due to on-demand operation only
- Self-diagnostics for both unit and system operation to shut down in the event of malfunctions
- Cost-effective installation with few mechanical and electrical connections
- A fully brazed and leak-tested R452A cooling system, minimizing leakage risks
- A plug-and-play stand-alone design, which simplifies installation and commissioning while reducing potential errors
- No need for advanced settings
- A compact and easy-to-handle design
- Patent pending on IPS 8

Working principle

The Danfoss IPS 8 is factory-tested and ready to use in ammonia plants with a condenser pressure of more than 6,5 bar (94 psi). The purger is charged with 900 gram (31.7 oz) of R452A.

Only 2 mechanical connections are needed for the purger (see fig. 1). The flow of ammonia/NC gases from the main plant is done through the flange for ammonia (see 13 in Fig. 1 below), while the NC gas purge is done through the blow-off pipe after the purge restrictor (18).

Through the flange for ammonia (13), a mixture of ammonia gas and NC gases enters the heat exchanger (12) part of the purger.

The ammonia gas/NC gas mix is cooled down below the condensing temperature of the ammonia by the R452A circuit. At this point, ammonia gas condenses and returns by gravity to the ammonia plant whereas the NC gases accumulate in the heat exchanger (12) for subsequent purging.

By condensing the ammonia gas, a new ammonia/NC gases mix is naturally pulled through. This new mix is separated through a continuous process.

As the NC gas concentration in the heat exchanger (12) increases, the R452A heat exchanger pressure and temperature will simultaneously decrease.

The controller continuously monitors the R452A heat exchanger pressure as well as ammonia pressure and temperature. When the R452A pressure reaches a predefined pressure difference when compared with the ammonia pressure (temperature) it prepares to purge the NC gases through the solenoid valve (16). The blow-off is activated by the solenoid (16) and through appropriate piping/hosing, should be led into a water bath. This process is recommended to retain small amounts of ammonia (see Installation section).

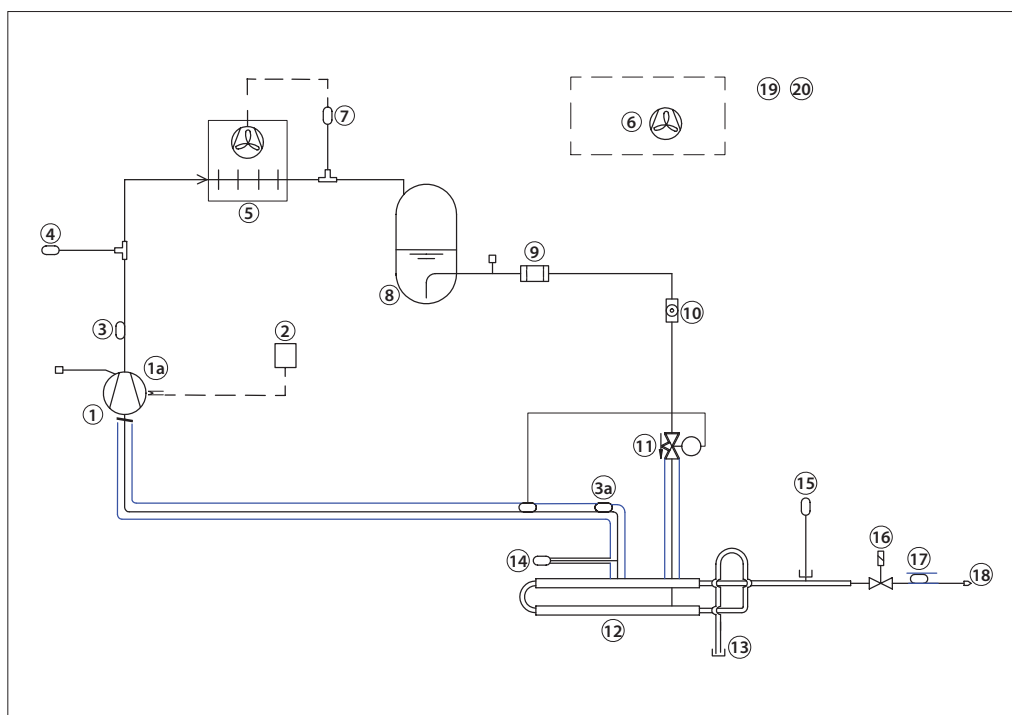

Fig. 1 - Purger R452A lay-out

1	Compressor R452A	11	Expansion valve, R452A
1a	Compressor Crankcase heater	12	Heat exchanger Ammonia/R452A
2	Thermostat for crankcase heater control	13	Welding Flange
3	Discharge temp sensor R452A	14	Pressure transmitter R452A
3a	Suction temperature sensor R452A	15	Pressure transmitter R717
4	Pressure safety switch	16	Solenoid valve AKVA and coil
5	Condenser	17	NC temperature sensor R717
6	Extraction fan	18	Restrictor, purge line
7	Pressure switch for Fan	19	MCX 15 (Pre-programmed)
8	Receiver	20	PSU, 24V
9	Filter		900 gram (31.7 oz) R452A
10	Sight glass		

Working cycle

The Danfoss IPS 8 operates in 24-hour cycles, of which 45 minutes are dedicated to an R452A pull down. At power on, the pull down is initiated immediately. If no NC gases are detected during the 45 minute pull down, the system will close the solenoid valve at purge point 1 and open the solenoid valve at point 2. After a cycle time of 24 hours/N (Number of purge points), the compressor will pull down again condensing the ammonia. After 24 hours, all purge points have been vented one time.

this to be a high concentration of NC gases and opens the purge solenoid valve. The purge valve will stay open until sufficient condensing ammonia is present to lift the R452A evaporating temperature above the upper threshold.

The compressor will continue running and if the temperature again decreases below the lower threshold, a new purge will be performed. This process will be repeated until the R452A heat exchanger temperature stays above the lower threshold for >45 minutes following the previous closure of the purge valve.

To identify NC gases, the controller utilizes upper and lower thresholds for R452A evaporating temperature. If, during pull down, the temperature continues decreasing and the lower threshold is passed, the controller considers

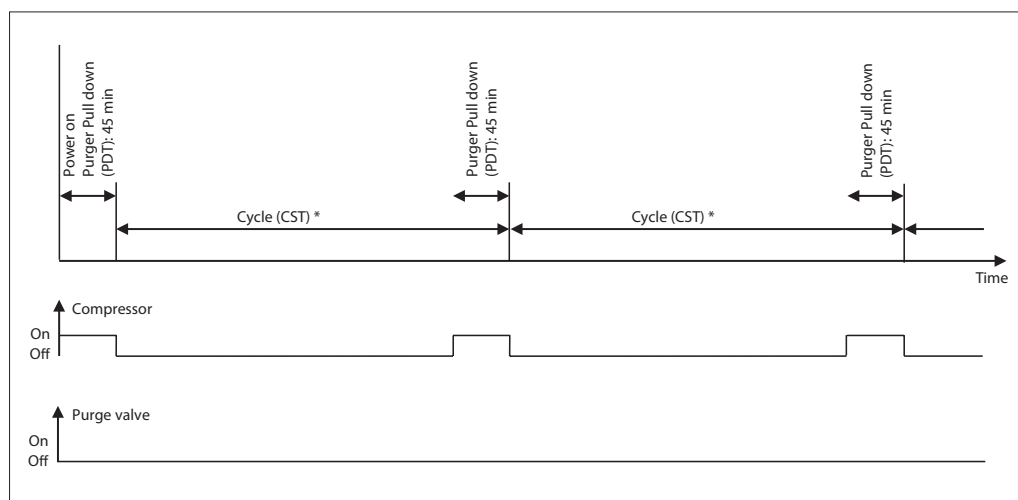

Fig. 2 - Power on & Cycle at no NC gases present: CST (compressor start time) and PDT (pull down time) are configurable
 * Cycle (CST) = 24 hours/N (number of purge points)

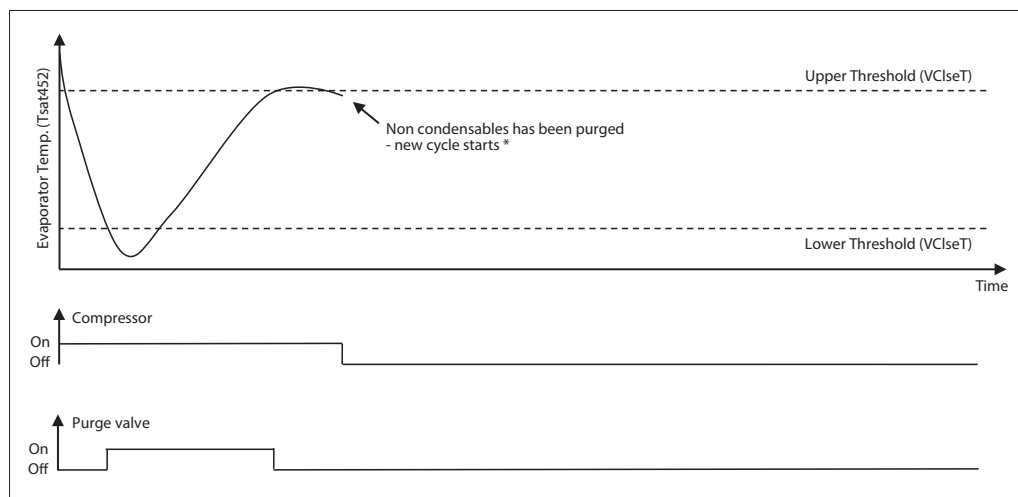

Fig. 3 - Purging procedure - Low R452A evap. temperature detected during PDT: Thresholds are configurable
 * If low evaporator temperature is detected (passing lower threshold), the purging procedure will be repeated immediately

Air traps

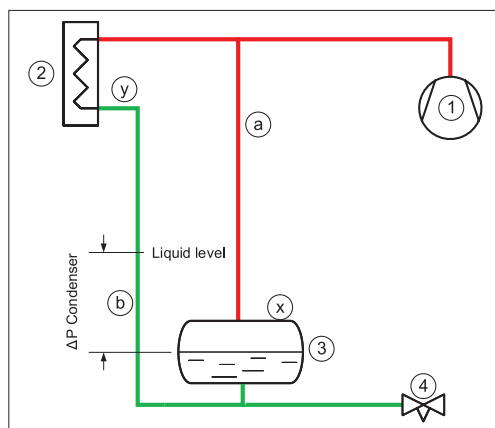

Fig. 4 Liquid level. Bottom connected receiver

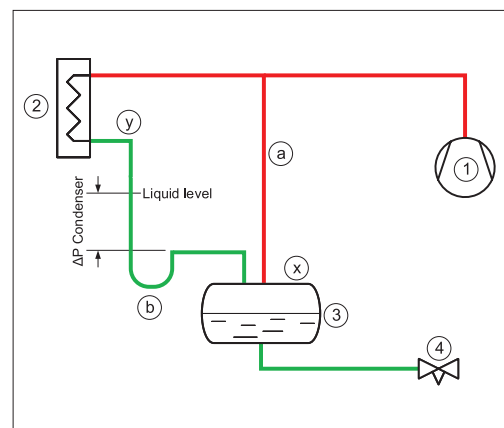

Fig. 5 Liquid level. Top connected receiver

For systems with low pressure liquid level control, the correct condenser/ receiver installation is as shown in Fig. 4 and Fig. 5.

The discharge gas from the compressor (1) is led to the condenser (2) where it is condensed. The receiver (3) holds the liquid until there is a demand for liquid from the LP side, e.g., until the expansion valve (4) opens. If the expansion valve is closed, the liquid condensed in the condenser will need to be stored in the receiver and the level will increase. To ensure a free flow to the receiver, the gas must be allowed to leave the receiver; this process is accomplished through the pressure equalizing line (a). The pressure equalizing line makes the pressure in the receiver the same as in the compressor discharge line. The pressure in the condenser outlet is lower due to the pressure loss in the condenser. Since the condenser outlet pressure is lower than in the receiver, it is therefore necessary to mount the condenser higher than the receiver and allow for a higher liquid level in the piping between the condenser and the receiver (b).

The liquid column in the line (b) compensates for the pressure difference between the condenser outlet and the receiver.

Fig. 4 shows the liquid connection at the bottom of the receiver.

If the liquid from the condenser is connected to the top of the receiver (Fig. 5), a slightly different arrangement must be made.

The liquid line (b) from the condenser to the receiver will need to have a goose neck/liquid trap to ensure that the liquid column is actually established.

As air is heavier than ammonia gas, the air will collect in two locations in this type of installation: On top of the liquid in the receiver (x) and/or on top of the liquid in the drop leg from the condenser (y).

Connection locations

Air purger installation in a low-pressure liquid level controlled installation

The correct locations for the air purger to be connected to the ammonia plant are:
(See Fig. 6 and Fig. 7)

- on top of the receiver or
- on top of the liquid in the drop leg from the condenser.

The air purger (5) is connected to the two purge points through solenoid valves (px and py). Note that only one solenoid should be open at any given time, otherwise the liquid column in

the condenser will be short-circuited. The air purger must have its own liquid return drop leg (c) connected in parallel with the condenser's drop legs (b).

When the purger is connected to the receiver i.e. solenoid (px) open, the liquid level in the air purgers drop leg (c) will be equal to the receiver liquid level (3); when the purger is connected to the condenser outlet i.e. solenoid (py) open, the liquid level will be equal to the liquid level in the condenser drop leg (b).

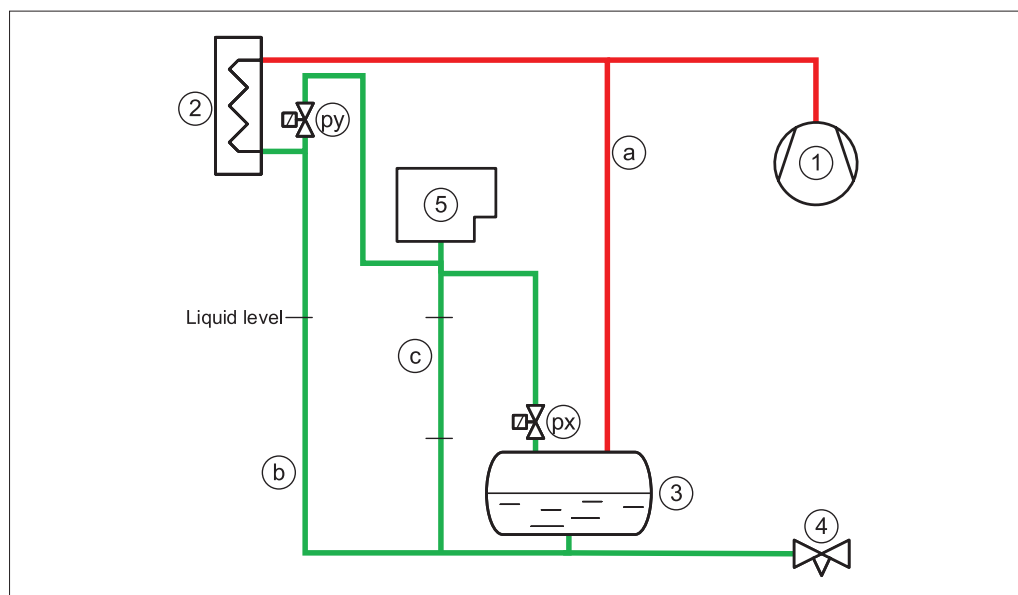

Fig. 6 Purger connections (px) & (py). Drain piping (c) must be vertical/downward slope

Alternatively, the air purger draining of liquid can be achieved effectively through an HP float valve (6) to the low pressure side (see Fig. 7).

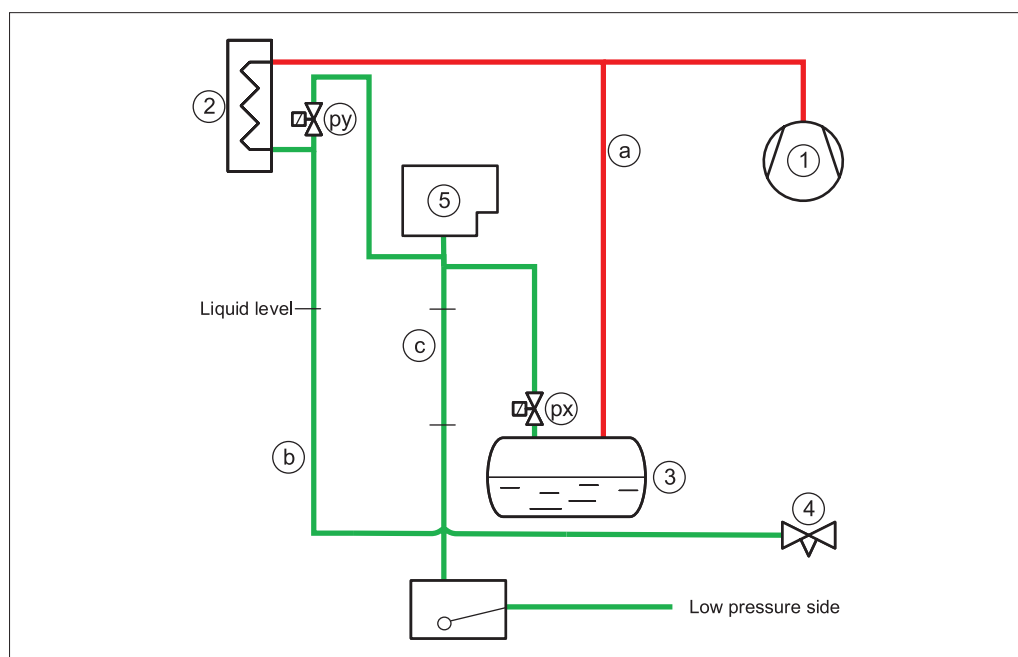

Fig. 7 Purger connections (px) & (py). Drain piping (c) must be vertical/downward slope

Connection locations
(continued)

Air purger installation in a high-pressure liquid level controlled installation

For systems with a high-pressure liquid level control, the air will collect in the float valve (3). (See Fig. 8).

The ammonia liquid condensed in the air purger must be drained through drain pipe (c) to the LP side via a float valve (6).

The compressor (1) supplies high-pressure gas to the condenser (2), where it is condensed. The float valve (3) will flash any liquid back to the LP side. The air purger (5) must be connected to the float valve through a solenoid valve (pv).

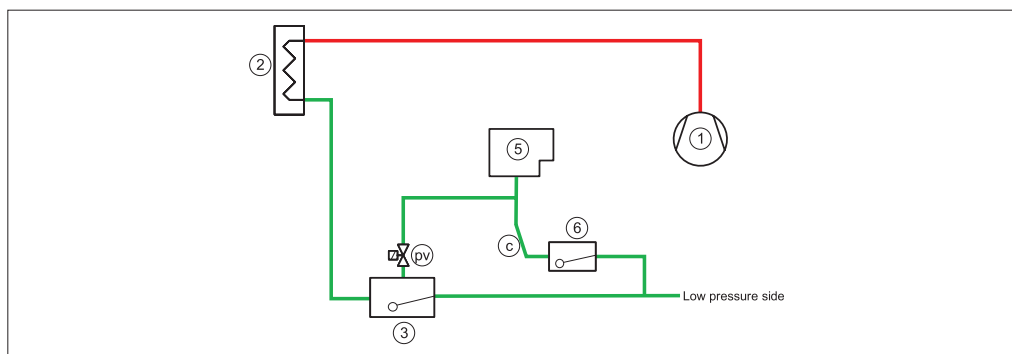

Fig. 8 Purger connections (pv). Drain Piping (c) must be vertical/downward slope

General



The air purger must always be mounted above the highest liquid level to be able to drain the ammonia condensed in it. Otherwise, the air purger can flood and potentially purge ammonia liquid.

The purger liquid return leg (c) must always be mounted vertically or at minimum, with a downward slope.

The solenoid valves at the connection points must never be activated at the same time. Finalize purging at one location before switching to the next.



WARNING !

Cod. 99000572

Follow the installation guide strictly during Purger installation. Install the Purger unit in a location where the bottom flange level and any gas inlet connection level is above any possible ammonia liquid level.

Liquid drain piping from the purger must always have a downward slope.

Install a shut off valve close to the bottom flange entrance to enable removal of the unit and closing for high pressure ammonia gas.

Connect proper resistant piping to the purging outlet pipe and ensure the purged non-condensables are discharged into a water bath of max. 200 liter.

Connection points

Multi-point purging

Single point purging setup is possible (Fig. 09) i.e. no solenoid valves with the Danfoss IPS 8 unit. This kind of installation should be installed as shown in Fig. 9 i.e. above the receiver or using a float valve. (See section on connection locations).

For single point purging as in Fig. 09, the setting in the MCX for the number of valves to '0' or switch off the multi-purging functionality in the general setup (y02).

As factory default, the Danfoss IPS 8 is configured to handle 8 purge points. The correct amount of purge points connected needs to be setup in the MCX controller after power-up. Both power and control wiring of the installed solenoid valves coils should take place prior to first power up.

NEVER HAVE MORE THAN 1 PURGE POINT OPEN AT A TIME.
Always close one purge valve before opening the next.

This is done by turning the purger unit power on (label y02) and entering the number of actual purge points in the program. See section "Programming/configuration".

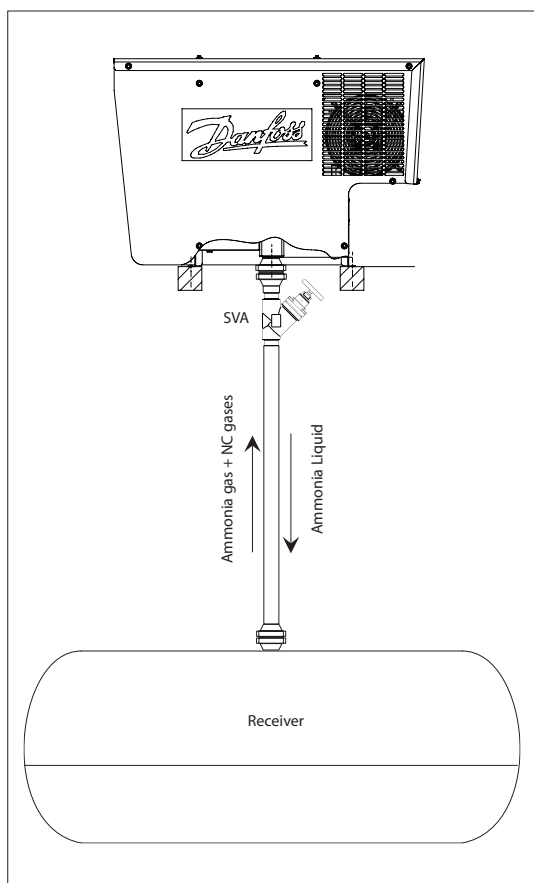

Fig. 9 Single point purging from receiver

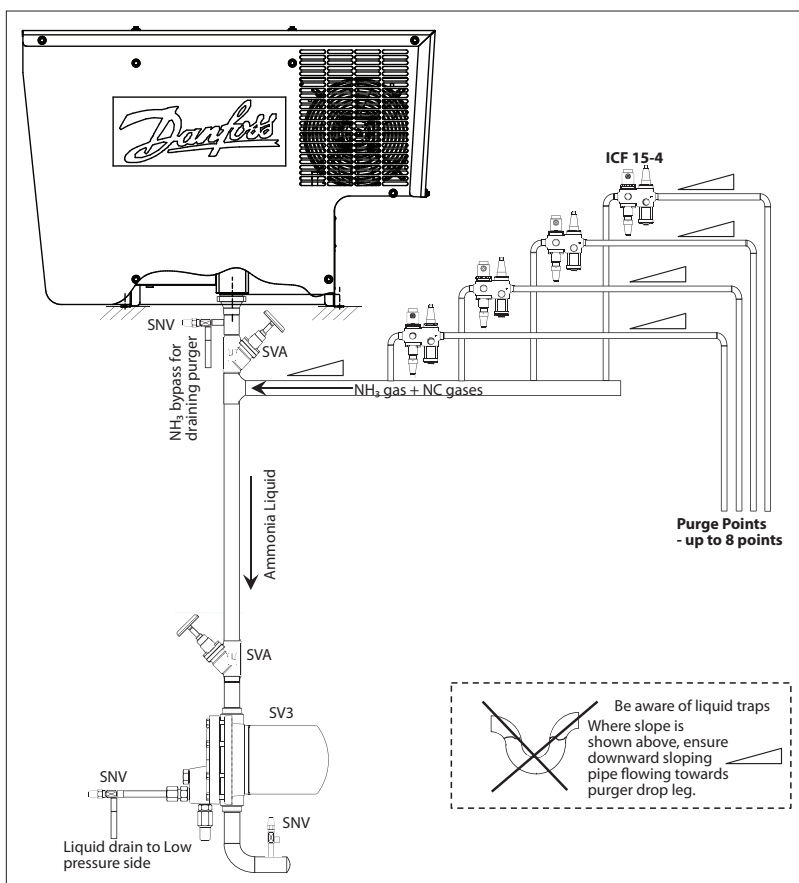

Fig. 10 Multi-point purging from up to 8 purging points

Installation

The Danfoss IPS 8 must be installed in accordance with locations recommended in the Connection locations and Connection points sections of this document.

The unit has a protection rating of IP55 and may be installed outside, in ambient temperature ranges from from -10 °C to 43 °C / 14 °F to 109 °F). Avoid installation in direct sunlight as this may lead to excessive sunlight exposure and ambient temperatures above allowed limits. For ambient temperatures below -10 °C (14 °F) the air purger must be installed in a heated and ventilated area. The unit must be installed in a non-ATEX atmosphere as the purger unit is not explosion proof.

The purger unit should be kept in an upright position at all times - from receipt to final installation.

Use all 4 lifting eyes and suitable lifting gear during installation (unit weight = 100 kg/220 lbs).

Install the unit on an even horizontal base 0.05 to 1.1 meter (2 to 43 in) above a service platform with sufficient support and allowing the purger subframe to be bolted to the support (see example in Fig. 12). Maintain recommended distances in all directions (Fig. 12) to allow fan cooling and servicing.

Always leave the unit off for at least 12 hours from finished installation to first time power up.



It is important that the support construction is level to ensure the internal liquid trap is properly filled.
Angle to horizontal < 2 degrees

Lifting Procedure

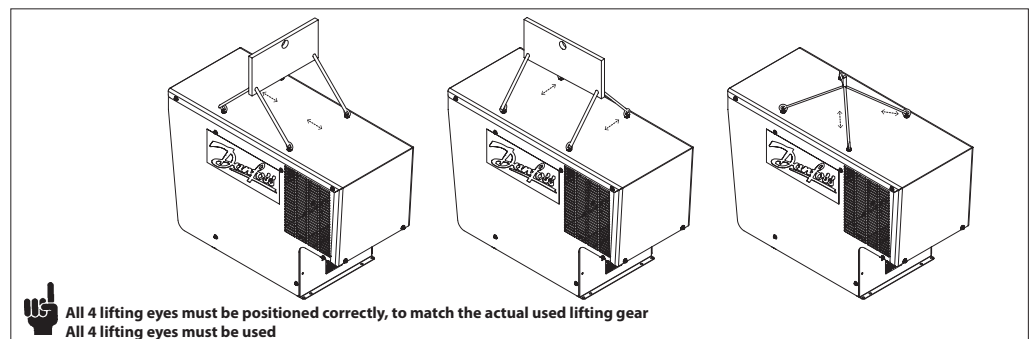

Fig. 11

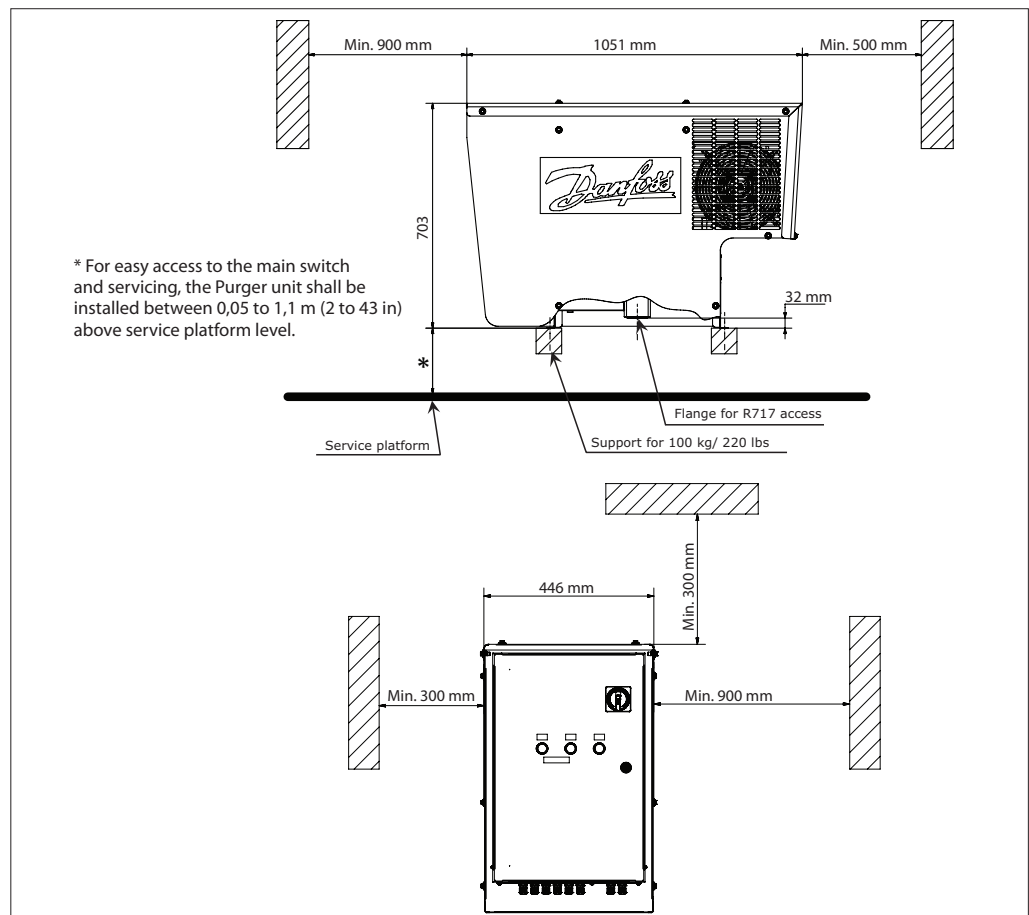

Fig. 12 Installation dimensions

Installation (continued)

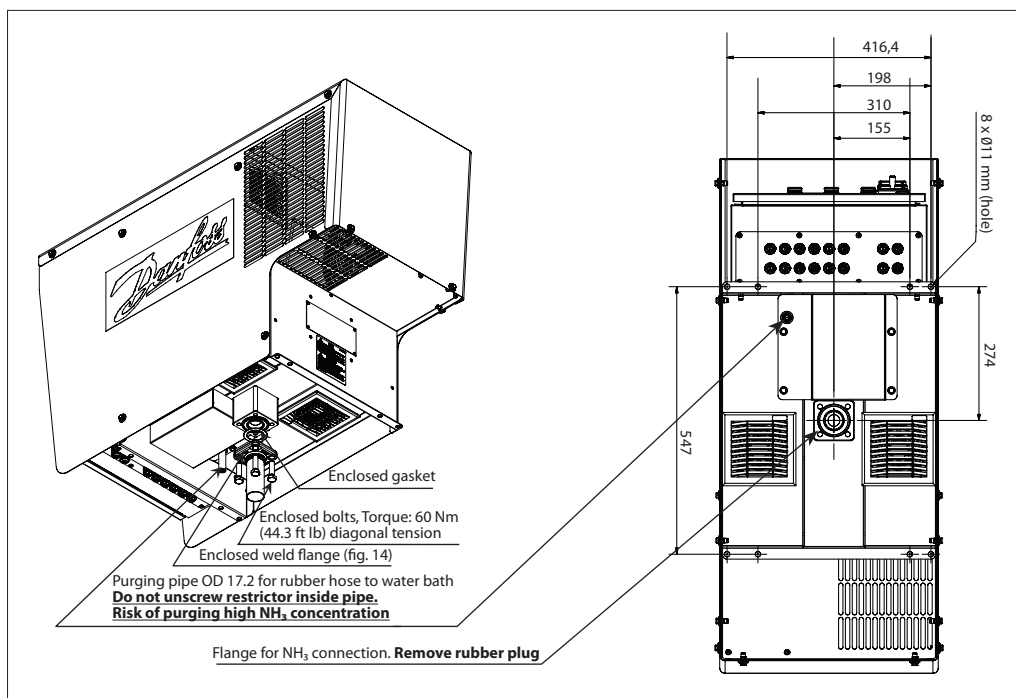

Fig. 13 Ammonia connection

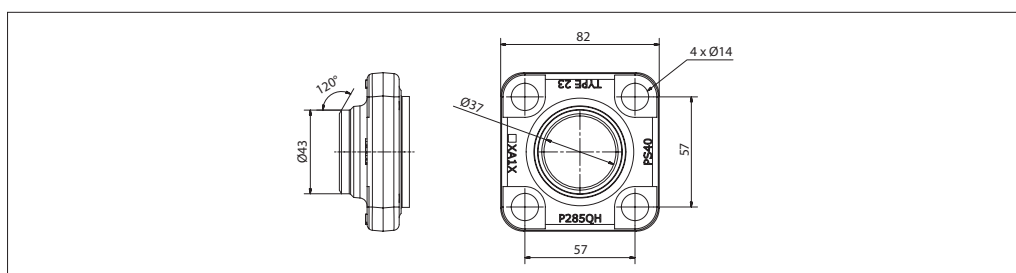

Fig. 14 Enclosed weld flange

1. Prepare the ammonia pipework with the weld flange according to Fig. 13 and Fig. 14. The main/drain piping should never be smaller than inner diameter Ø37 mm (1.5 in).
2. Complete the supporting structure able to carry 100 kg (221 lbs).
3. Lift the purger into position using the lifting eyes on each side of the purger's cabinet. Remove the rubber plug from the flange opening.
4. Connect the weld flange with the purger flange using the enclosed flat gasket and tighten the supplied 4 bolts diagonally to a torque of 60 Nm (44.3 ft-lb).
5. Insert 4 bolts (not supplied) through the purger frame and the support construction and tighten.
6. Perform a leak test to ensure an airtight connection.
7. In the event the purger unit needs to be dismantled please contact Danfoss for instructions.
8. Correctly install a suitable pipe/hose from the purge solenoid valve for blow-off of NC gases in accordance with local or national regulations.
9. Prepare an outside water tank with a maximum of 200 liters (53 gal.) and ensure the piping allows the purged gas to be immersed in the water.
10. Regularly check the pH level of the tank's contents.
11. The pH level should never exceed 12.6. Otherwise the water content must be renewed.
12. Dispose of concentrated waste water in accordance with to local/national regulations.



Note: Prior to replacing the water in the water tank ensure that the purger is switched off and the shut off valve at the flanged purger inlet is closed. Leave the unit in this condition for a period to allow the remaining gas in the piping to be dissolved/released.
Watch out for bubbles.

Establish a procedure for regular checking the pH level and bubble pattern. If continuous bubbles are observed in the water tank during "stand by" (Green light indicator) in normal operation, one or more of the purge solenoid valves needs repair or replacement.

Electrical wiring

The internal wiring of the purger is done at the factory. Only the electrical wiring for the main power supply, the purge point solenoids and optional bus communication needs wiring on site.

It is highly recommended that all external cables coming from the IPS 8 to the power supply and to all purge point solenoids are protected by metallic pipes.

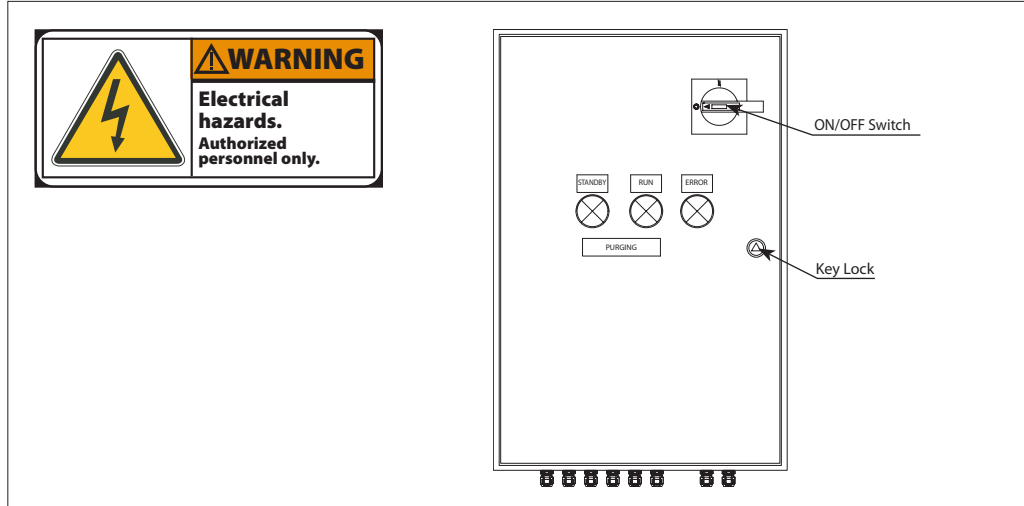

Fig. 15 Controller box external

Controller box cover can only be opened at key unlock and with the main switch off.

Note: Authorized personnel only

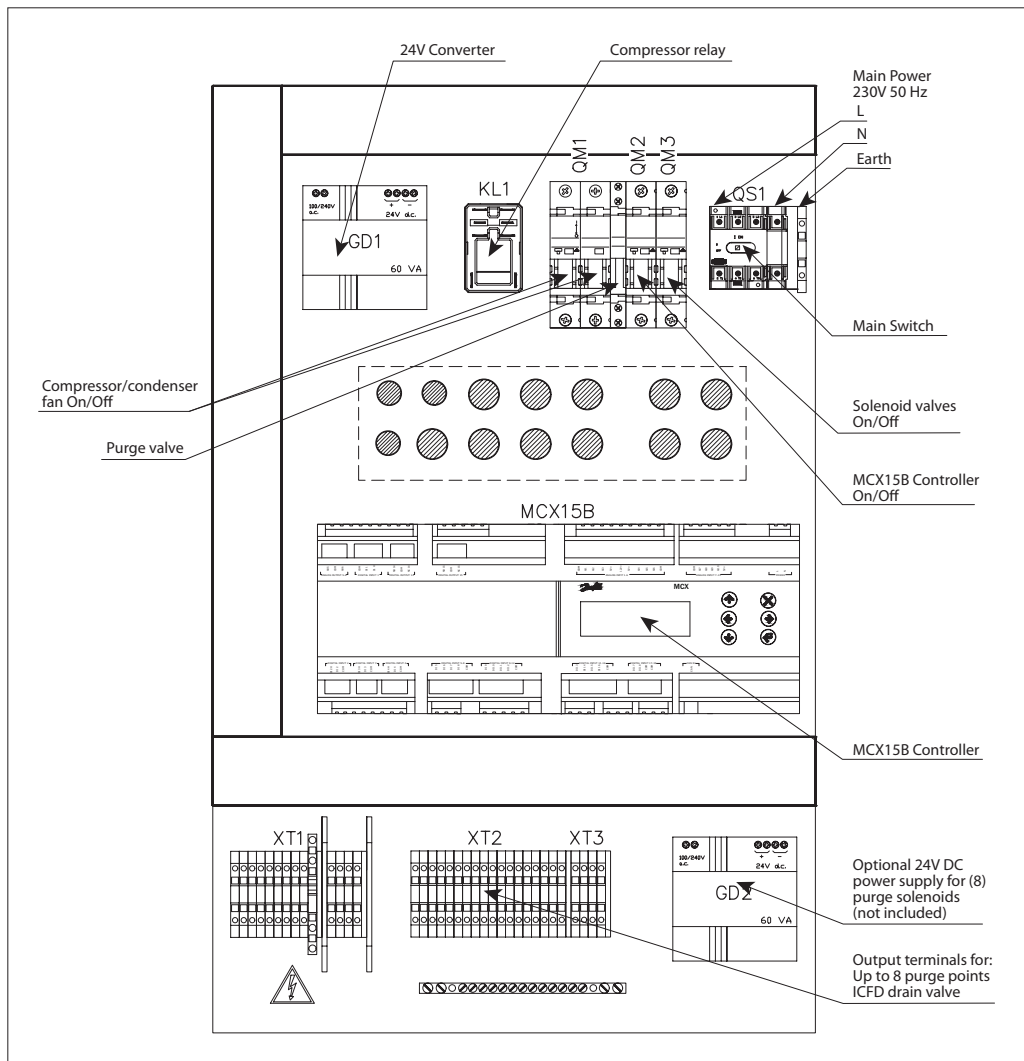

Fig. 16 Controller box internal

Electrical wiring
(continued)

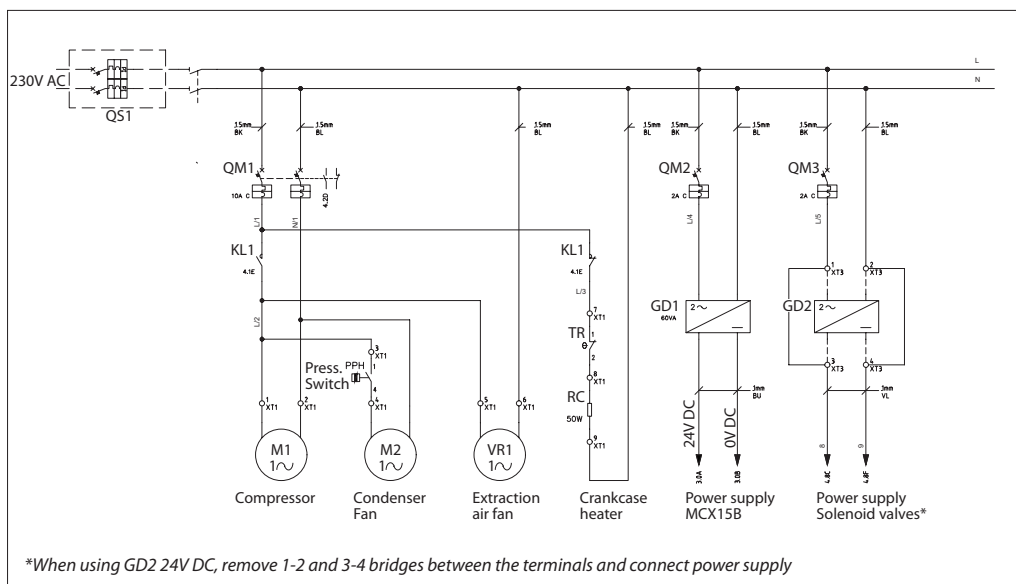

Fig. 17 Power Supply

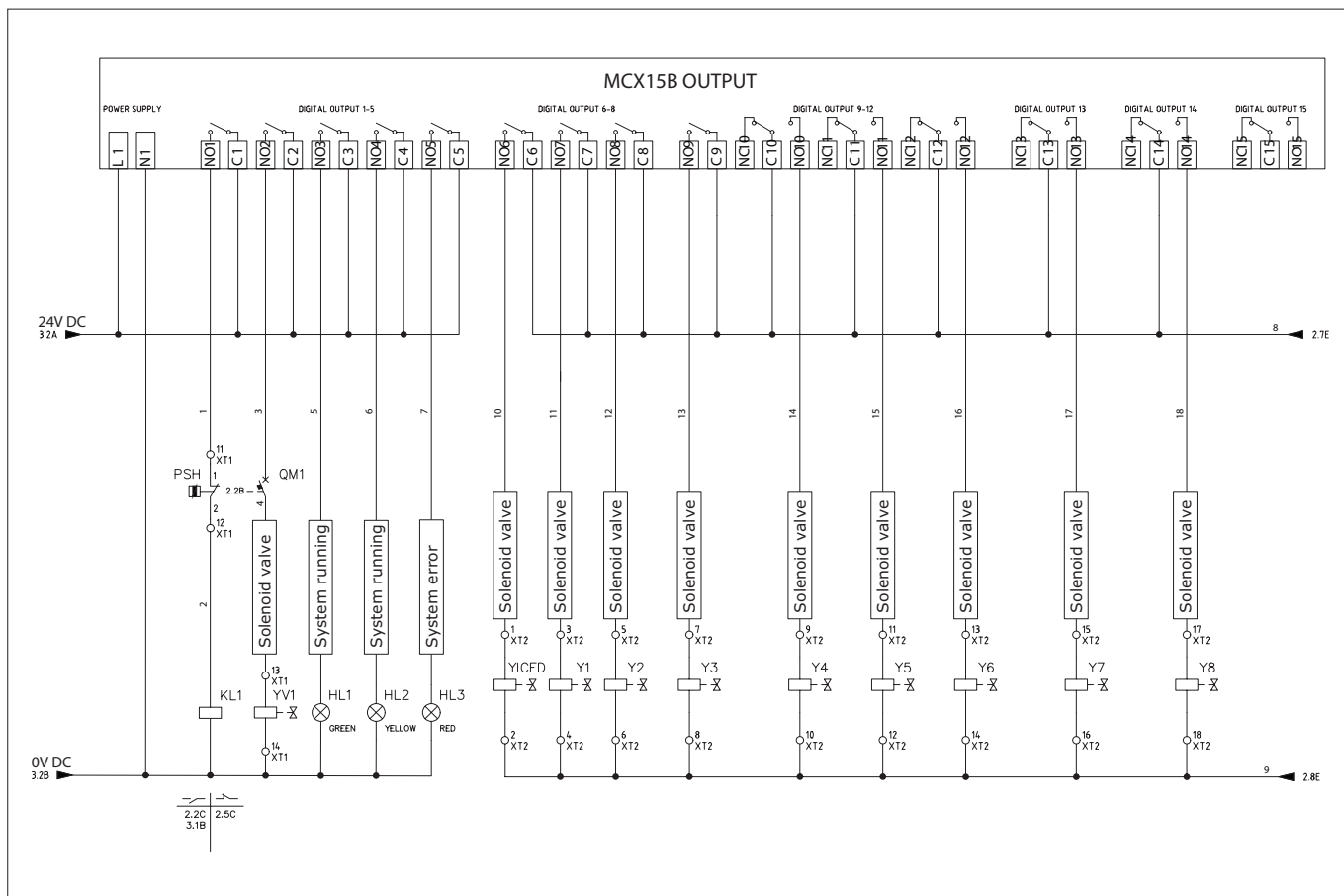

Fig. 18 Controller MCX15B Inputs and Outputs

Electrical wiring
(continued)

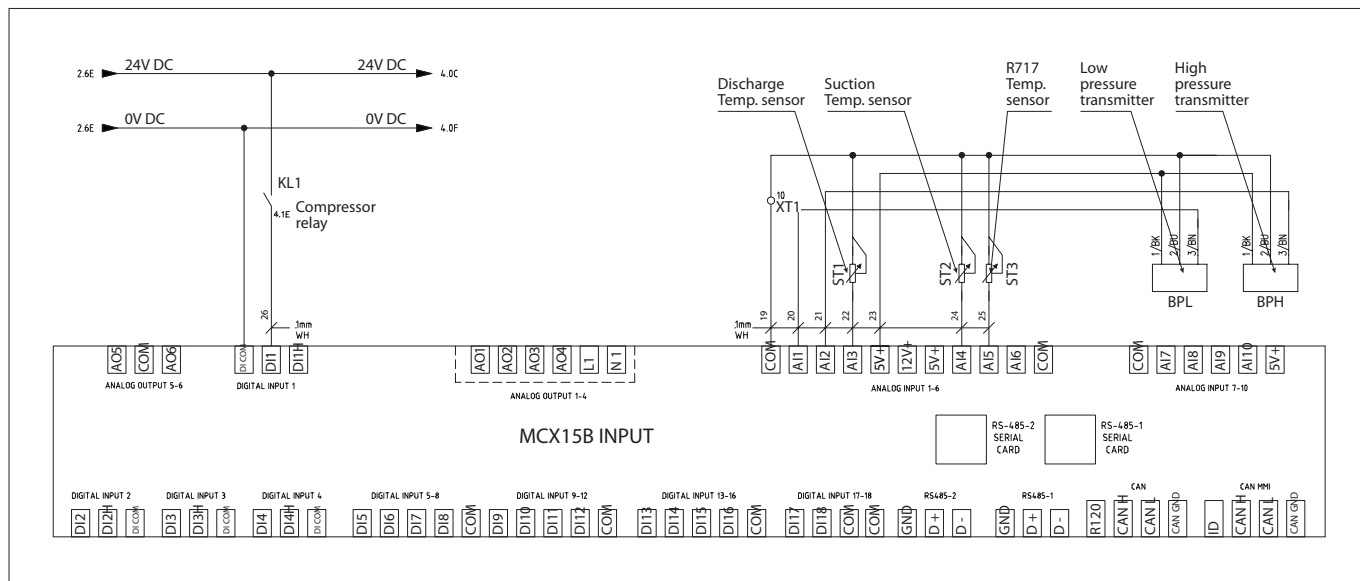

Fig. 19 Controller MCX15B Inputs

Light Indicators

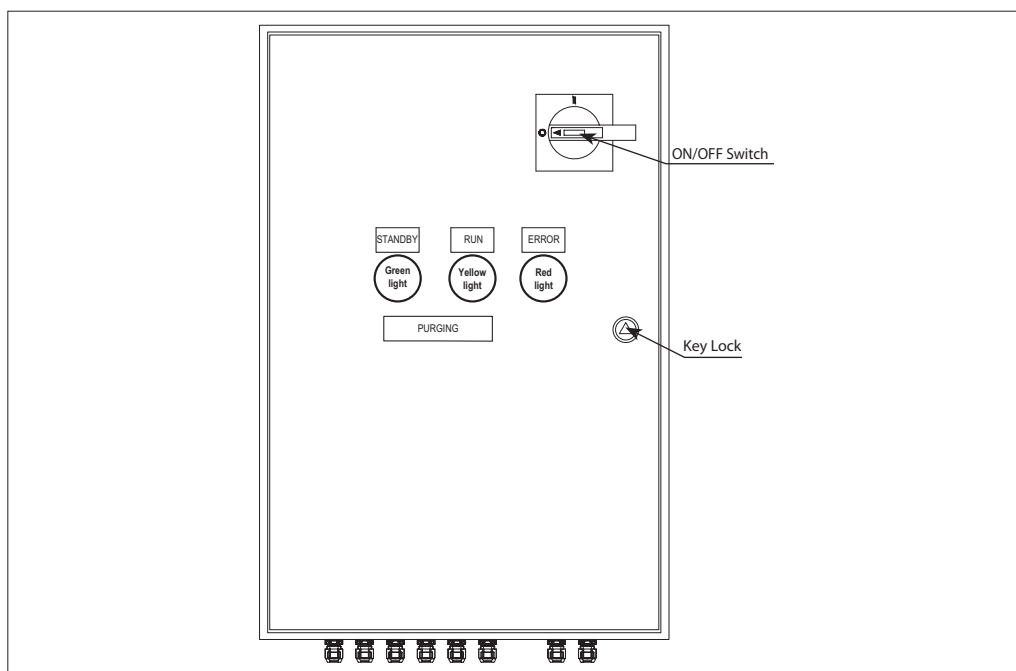

Fig. 20

Lights ON	Status	Compressor ON	Compressor OFF	Purge Valve ON	Purge Valve OFF	Alarm
Green	Stand by		X		X	
Yellow	Run	X			X	
Green & Yellow	Purging	X		X		
Green & Yellow & Red	Uninterrupted Long time purging (> 150 h)	X		X*		
Red	Occurs when: Check list of alarms description	(x**)	x**			X

* The purger continuous purging until max running period (default 160 h) is reached and the purger compressor will stop
 ** The purger compressor stops when alarm occurs

Quick Startup

For the fastest possible system configuration after connecting all purge points to the IPS and following first power up of the IPS, follow these simple instructions:

1. Navigate from the Main Menu to Login
2. Enter password '200'.
3. Choose 'Parameters'.
4. Choose 'Unit Config'
5. Choose 'Valve Settings'
6. Enter the amount of purge solenoid valves connected to the IPS.

Navigation - built in MCX controller

(Placed at the rear of the front panel door)

After switching on the controller, a display window will momentarily show the actual software version, followed by the default main operating window shown in Fig. 26.

While in operation mode, the Up/Down arrow buttons lead the user to the status windows described in Table 01 below.

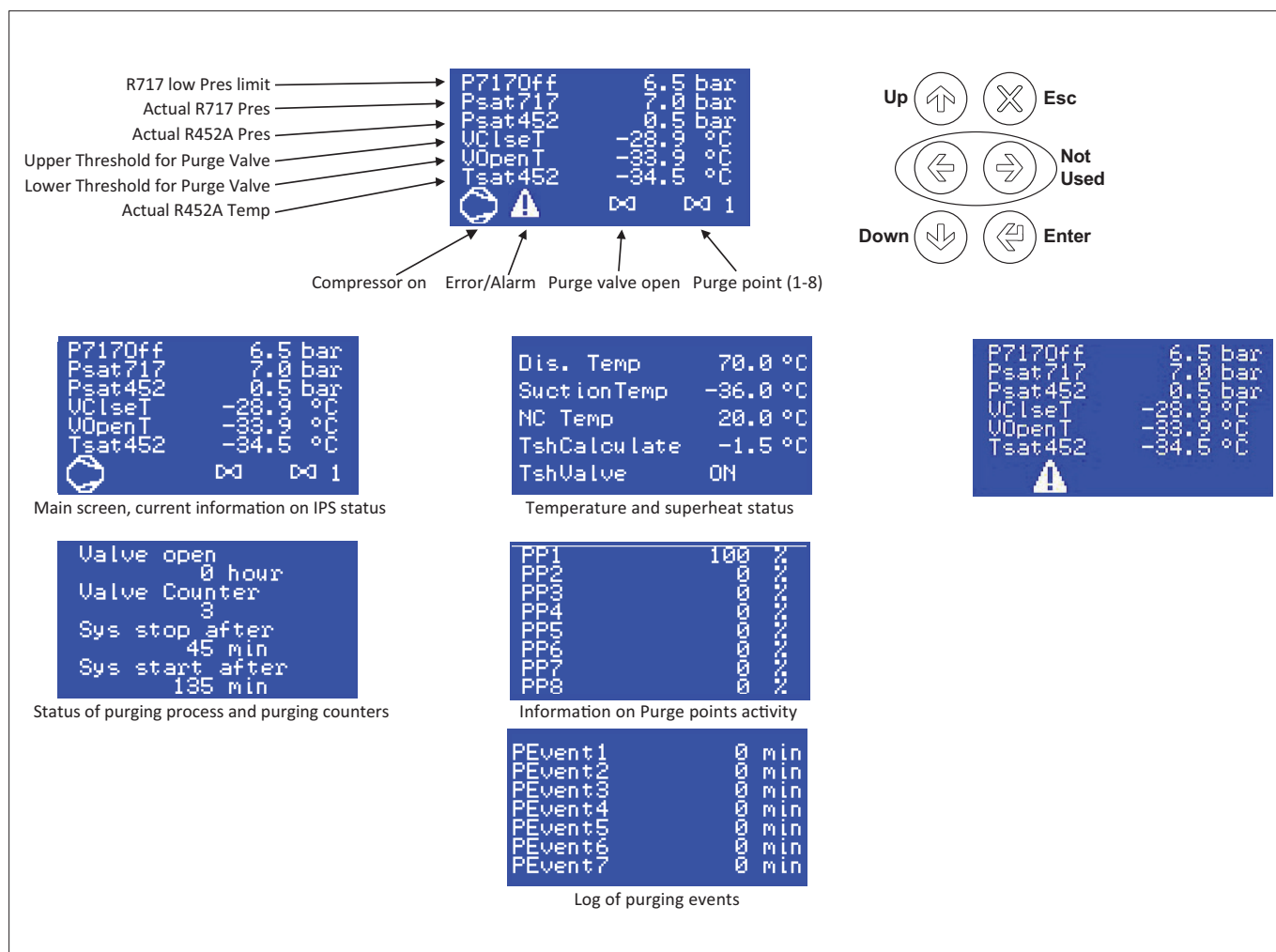

Fig. 21 - Default main window. Operating (start) mode. (Examples only)

Table 01 - Status windows

Purge Point percentage	↑	Distribution of the actual purging on the various purge points
Dis. temp.	↑	Actual R452A discharge temperature (°C)
Main Window	default	See above
Cycle info	↓	Acc. time Purge valve open (h)
Past events	↓	Last 7 purging events (min)

Configuring using the LCD

By pressing the main menu will show up with the options below

Table 02
Main menu navigation

Main Menu	Submenu	Submenu/status	Submenu/status	Min	Max	Default	Description	Label
Alarms	Active alarms	No alarm						
		up to 15 alarms (see table below)					Up to 15 possible alarms listed by arrow up/down	
	Reset alarms						Reset all actual alarms	
	Log history						View log history	
	Clear log history						Clear log history	
Login	Password	***				200	N/A	
Start	Turn On						Main switch ON	
	Turn Off						Main switch OFF	
Parameters	Unit config	Compressor		0 sec	100 sec	20 sec	SDT (Compressor start delay)	CM2
				5 min	2000 min	45 min	PDT (Pull down time)	CM3
				180 min	2000 min	1440 min	CST (Cycle time)	CM4
				24 hours	768 hours	160 hours	PLT (Endless purging max time)	VA5
		Limits settings		0 bar	5 bar	0.5 bar	Comp Diff (Hysteresis min allowed ammonia pressure)	CM5
			0 bar	12 bar	6.5 bar	Setpoint to start compressor	CM1	
	Input/Output						Input / Output Display & Config	

**Table 03
Occurring active alarms, possible reasons and recommended action**

Label	Parameter Name	Description	Possible Reason	Recommended action
ALARMS				
A01	General alarm	Input from AI3 Leads to shut down of IPS 8	Fault in system connected to the DIO4	Input from AI3 Leads to shut down of IPS 9
E01	Temp Sensor Fault	Indicates no signal from temperature sensor (R452a)	Broken wire to R452a temperature sensor	Repair temperature sensor wire or replace temperature sensor
E01	Temp Sensor Fault	Indicates no signal from temperature sensor (R452a)	Electrical supply failure supplying R452a temperature sensor	Repair or replace power source
E01	Temp Sensor Fault	Indicates no signal from temperature sensor (R452a)	Temperature measurement of the R452a line is out of range	Compare temperature with another temperature sensor reading and replace temperature sensor if needed
E02	BPL Sensor Fault	Indicates no signal from pressure transmitter (R452a)	Broken wire to R452A pressure transmitter	Repair pressure transmitter wire or replace pressure transmitter
E02	BPL Sensor Fault	Indicates no signal from pressure transmitter (R452a)	Electrical supply failure to the R422a pressure transmitter	Repair or replace power source
E02	BPL Sensor Fault	Indicates no signal from pressure transmitter (R452a)	Pressure measurement of the R452a line is out of range	Compare pressure with another pressure reading and replace pressure transmitter if needed
E03	BPL Sensor Fault	Indicates no signal from pressure transmitter (R717)	Broken wire to R717 pressure transmitter	Repair pressure transmitter wire or replace pressure transmitter
E03	BPL Sensor Fault	Indicates no signal from pressure transmitter (R717)	Electrical supply failure to the R717 pressure transmitter	Repair or replace power source
E03	BPL Sensor Fault	Indicates no signal from pressure transmitter (R717)	Pressure measurement of the R717 line is out of range	Compare pressure with another pressure reading and replace pressure transmitter if needed
E04	Low temperature	Indicates too low ambient temperature (<-10 °C)	Too low ambient temperature	Move the IPS to a higher ambient temperature
E05	High temperature	Indicates too high ambient temperature (>120 °C)	Too high ambient temperature	Move the IPS to a lower ambient temperature
E05	High temperature	Low R452a charge because of possible leak	Locate and repair leak Evacuate	Move the IPS to a lower ambient temperature
E06	Low pressure BPL	Indicates too low R452a pressure	Choked restrictor / wrong connection	Factory setting 0.3 bar, we can have several problems: a) Restrictor is blocked (clean it). b) Wrong piping and as addition ammonia is draining, so check piping's. c) Check SV float
E07	High pressure BPL	Indicates too high R452a pressure	R452s system pressure too high	a) Expansion valve is not working b) To high ambient temperature (24 bar /54 °C)
E08	Low pressure BPH	Indicates too low R717 pressure	Closed stop valve	Purge points are blocked, or flange is blocked with rubber plug
E09	High pressure BPH	Indicates too high R717 pressure	R717 system pressure too high	Pressure is 24 bar
E10	System is OFF	Indicates status of the main switch	Main switch is OFF	Switch ON the main switch
E11	Memory is full	A memory reset is required	Memory is full from long time operation	Clean MCX memory by means of finding Parameters_UnitConfig_
E12	Totla purge time error	This occurs when PLT is activated System will automatically restart when CST has expired	Restrictor is blocked	Replace the restrictor
E13	Compressor ERROR	Indicates no status is being received from relay KL01	Possible broken wire from the MCX	Repair broken wire from the MCX
E14	Liquid alarm	Signal from the LLS that there is liquid in the evaporator		
E15	Memory wrong!	Wrong counter values The unit will automatically repair itself		
E16	Discharge sensor error	Indicates no signal from temperature sensor		
E17	Suction sensor error	Indicates no signal from temperature sensor		

All alarms except (*) activates red light on box outside

For alarms not resettable and/or cause not identified, please contact Danfoss

Level legend: 0 = Read view, 2 = Installer view (code 200) 3 = Danfoss Service view (Contact Danfoss)

Modbus RTU
Good Practice

The wiring of Modbus RTU (RS485) must be carried out in accordance with the standard ANSI/TIA/EIA-485-A-1998.

Galvanic separation shall be provided for segments crossing buildings.

Common ground shall be used for all devices on the same network inclusive router, gateways etc.

All bus connections in the cables are made with twisted pair wires.

The recommended cable type for this is AWG 22/0.32 mm². If used for longer distances please use a AWG 20/0.5mm² or AWG 18/0.75mm² cable. The cables characteristic impedance shall be between 100 – 130Ω The capacitance between conductors shall be less than 100 pf per meter.

Note: the length of the cables influence the communication speed used. Longer cable lengths mean lower baud rate should be used.

Maximum cable length allowed is 1200m.

Use a minimum 20 cm distance between 110V/230V/400V power line cables and bus cables.

Table 04
Modbus RTU Registers

Register	Parameter Name	Description	User Level	Min Value	Max Value	Default Value	Unit/ Type	Read/ Write	Modbus Function Code	Modbus Data Type	Persistent Yes/No
GENERAL > SETUP											
3001	ON/OFF	0: Main switch off 1: Main switch on	2	0	1	1	Enum 1	RW	3/6	Short	Yes
3002	Activate Multipurger	Switch on/off multipurging functionality 0: No 1: Yes, switch on multipurging functionality	2	0	1	1	Enum 2	RW	3/6	Short	Yes
3003	Restore default parameters	0: No 1: Yes, restore default parameters	2	0	1	0	Enum 2	RW	3/6	Short	Yes
GENERAL > SERIAL SETTINGS											
3007	Serial address (Modbus and CAN)		2	1	100	1	N/A	RW	3/6	Short	Yes
3008	Serial baudrate (Modbus)	The rate at which information is transferred in the RS485 communication channel 0: 0 1: 12 2: 24 3: 48 4: 96 5: 144 6: 192 7: 288 8: 384	2	0	8	6	Enum 3	RW	3/6	Short	Yes
3009	Serial settings (Modbus)	0: 8N1 1: 8E1 2: 8N2	2	0	2	1	Enum 4	RW	3/6	Short	Yes
GENERAL > PASSWORD											
3010	Password level 1	password for user level 1	3	0	999	100	N/A	RW	3/6	Short	Yes
3011	Password level 2	password for user level 2	3	0	999	200	N/A	RW	3/6	Short	Yes
UNIT CONFIG > COMPRESSOR											
3014	PDT	Pull down time of compressor	2	5	CM4	45	min	RW	3/6	Short	Yes
3015	CST	Delay between purge cycles (single purge)	2	180	2000	1440	min	RW	3/6	Short	Yes
3016	PLT	Alarm for endless purging	2	24	768	24	h	RW	3/6	Short	Yes

User Guide | Intelligent Purging System (IPS 8) Ammonia

Register	Parameter Name	Description	User Level	Min Value	Max Value	Default Value	Unit/Type	Read/Write	Modbus Function Code	Modbus Data Type	Persistent Yes/No
UNIT CONFIG > VALVE SETTINGS											
3022	Max_PP	Used amount of purge points - part of initial setup	2	0	8	8	N/A	RW	3/6	Short	Yes
UNIT CONFIG > LIMITS SETTINGS											
3034	Setpoint	Pressure threshold for compressor	2	0,0	12,0	6.5	bar	R/W	3/6	Short	Yes
3035	Tsh	Setpoint for superheat	2	5,0	40,0	15	°C	R/W	3/6	Short	Yes
STATUS VAR > MCX DESIGN HOTSPOTS											
1859	Reset Alarms	Reset alarm	0	0	2	0	N/A	R/W	3/6	Short	Yes
8101	SystemOnOff	Feedback from the main switch	0	-32768	32767	0	Enum 1	Read only	3	Short	No
8102	ValveStatus	Feedback from the purge valve - open/closed	0	-32768	32767	0	Enum 1	Read only	3	Short	No
8103	CompressorStatus	Feedback from the compressor - on/off	0	-32768	32767	0	Enum 1	R/W	3/6	Short	Yes
8104	ALARActive	Any alarm active indicator	0	-32768	32767	0	Enum 2	Read only	3	Short	No
8105	PressTotemp	Suction temperature (calculated from pressure on suction)	0	-327,7	327,7	0	°C	Read only	3	Short	No
8106	ValveCount	The amount of purge valve activations	0	-2147483648	2147483647	0	N/A	Read only	3	Long	No
8108	ComprTime	Remaining time for compressor pull-down for the actual purge pointr cycle	0	-2147483648	2147483647	0	Minutes	Read only	3	Long	No
8110	COmprStartAfter	The delay between the purging cycles	0	-2147483648	2147483647	0	Minutes	Read only	3	Long	No
9901	Advanced Setting - ResetMem	Recommend default setting only - All logged values are reset 0: NO 1: YES	0	0	1	0	Enum 2	R/W	3/6	Short	Yes
8112	ValveHour	The amount of hours that the main purge valve has been active	0	-214748364,8	214748364,7	0	Hours	Read only	3	Long	No
8114	StatusKL	Status of KL01 relay (compressor and crankcase heater)	0	-32768	32767	0	Enum 2	Read only	3	Short	No
8115	WaringCompr	Indicates problem with compressor status	0	-32768	32767	0	Enum 2	Read only	3	Short	No
8116	ValveSetpoint	Temperature threshold for the opening of the main purge valve	0	-2147483648	2147483647	0	°C	Read only	3	Short	No
8117	ValveClose	Temperature threshold for the closing of the main purge valve	0	-2147483648	2147483647	0	°C	Read only	3	Long	No
8119	Event1	Purge cycle event - counts the minutes that the purge valve has been open on a finished cycle	0	-3276,8	3276,7	0	Minutes	Read only	3	Long	No
8121	Event2	Purge cycle event - counts the accumative minutes that the purge valve has been open on a finished cycle	0	-3276,8	3276,7	0	Minutes	Read only	3	Long	No
8123	Event3	Purge cycle event - counts the accumative minutes that the purge valve has been open on a finished cycle	0	-3276,8	3276,7	0	Minutes	Read only	3	Long	No

Register	Parameter Name	Description	User Level	Min Value	Max Value	Default Value	Unit/ Type	Read/ Write	Modbus Function Code	Modbus Data Type	Persistent Yes/No
8125	Event4	Purge cycle event - counts the accumative minutes that the purge valve has been open on a finished cycle	0	-3276,8	3276,7	0	Minutes	Read only	3	Long	No
8127	Event5	Purge cycle event - counts the accumative minutes that the purge valve has been open on a finished cycle	0	-3276,8	3276,7	0	Minutes	Read only	3	Long	No
8129	Event6	Purge cycle event - counts the accumative minutes that the purge valve has been open on a finished cycle	0	-3276,8	3276,7	0	Minutes	Read only	3	Long	No
8131	Event7	Purge cycle event - counts the accumative minutes that the purge valve has been open on a finished cycle	0	-3276,8	3276,7	0	Minutes	Read only	3	Long	No
8133	PP1	The time percentage for this purge point	0	-32768	32767	0	%	Read only	3	Long	No
8135	PP2	The time percentage for this purge point	0	-32768	32767	0	%	Read only	3	Long	No
8137	PP3	The time percentage for this purge point	0	-32768	32767	0	%	Read only	3	Long	No
8139	PP4	The time percentage for this purge point	0	-32768	32767	0	%	Read only	3	Long	No
8141	PP5	The time percentage for this purge point	0	-32768	32767	0	%	Read only	3	Long	No
8143	PP6	The time percentage for this purge point	0	-32768	32767	0	%	Read only	3	Long	No
8145	PP7	The time percentage for this purge point	0	-32768	32767	0	%	Read only	3	Long	No
8147	PP8	The time percentage for this purge point	0	-32768	32767	0	%	Read only	3	Long	No
8149	Val1	This indicates if the purge point is active	0	-32768	32767	0	N/A	Read only	3	Short	No
8150	Val2	This indicates if the purge point is active	0	-32768	32767	0	N/A	Read only	3	Short	No
8151	Val3	This indicates if the purge point is active	0	-32768	32767	0	N/A	Read only	3	Short	No
8152	Val4	This indicates if the purge point is active	0	-32768	32767	0	N/A	Read only	3	Short	No
8153	Val5	This indicates if the purge point is active	0	-32768	32767	0	N/A	Read only	3	Short	No
8154	Val6	This indicates if the purge point is active	0	-32768	32767	0	N/A	Read only	3	Short	No
8155	Val7	This indicates if the purge point is active	0	-32768	32767	0	N/A	Read only	3	Short	No
8156	Val8	This indicates if the purge point is active	0	-32768	32767	0	N/A	Read only	3	Short	No
8158	TempStatus	The measured temperature on the discharge line of compressor	0	-32768	32767	0	°C	Read only	3	Short	No
8159	BPLStatus	The pressure on R452	0	-32768	32767	0	bar	Read only	3	Short	No
8160	BPHStatus	The pressure on R717	0	-2147483648	2147483647	0	bar	Read only	3	Short	No
8161	DisTemp	The measured temperature on the purge valve	0	-32768	32767	0	°C	Read only	3	Short	No

User Guide | Intelligent Purging System (IPS 8) Ammonia

Register	Parameter Name	Description	User Level	Min Value	Max Value	Default Value	Unit/Type	Read/Write	Modbus Function Code	Modbus Data Type	Persistent Yes/No
8162	SuctionTemp	The measured temperature on the suction line	0	-2147483648	2147483647	0	°C	Read only	3	Short	No
8163	TshValveStatus	The measured value of the superheat	0	-32768	32767	0	°C	Read only	3	Short	No
8164	TshCalculate	The calculated value of the superheat from the refrigerant type	0	-2147483648	2147483647	0	K	Read only	3	Long	No
ALARMS											
1901.08	General alarm	Input from AI3. Leads to shut down of IPS 8	0	0	1	0	AUTO R.	Read only	3	Long	No
1901.09	Temp Sensor Fault	Indicates no signal from temperature R452A sensor	0	0	1	0	AUTO R.	Read only	3	Long	No
1901.10	BPL Sensor Fault	Indicates no signal from pressure sensor (R452a)	0	0	1	0	AUTO R.	Read only	3	Long	No
1901.11	BPH Sensor Fault	Indicates no signal from pressure sensor (R717)	0	0	1	0	AUTO R.	Read only	3	Long	No
1901.12	Low temperature	Indicates too low ambient temperature (<-10 °C)	0	0	1	0	AUTO R.	Read only	3	Long	No
1901.13	Hi temperature	Indicates too high ambient temperature (>120 °C)	0	0	1	0	AUTO R.	Read only	3	Long	No
1901.14	Low pressure BPL	Indicates too low R452a pressure	0	0	1	0	AUTO R.	Read only	3	Long	No
1901.15	Hi pressure BPL	Indicates too high R452a pressure	0	0	1	0	AUTO R.	Read only	3	Long	No
1901.00	Low pressure BPH	Indicates too low R717 pressure	0	0	1	0	AUTO R.	Read only	3	Long	No
1901.01	Hi pressure BPH	Indicates too high R717 pressure	0	0	1	0	AUTO R.	Read only	3	Long	No
1901.02	System is OFF	Indicates status o the main switch	0	0	1	0	AUTO R.	Read only	3	Long	No
1901.03	Memory is full	A memory reset is required	0	0	1	0	AUTO R.	Read only	3	Long	No
1901.04	Totla purge time error	This occurs when PLT is activated. System will automatically restart when CST has expired	0	0	1	0	AUTO R.	Read only	3	Long	No
1901.05	Compressor EROR	Indicates no status is being received from KL01	0	0	1	0	AUTO R.	Read only	3	Long	No
1901.06	Liquid alarm	Signal from the LLS that there is liquid in the evaporator	0	0	1	0	AUTO R.	Read only	3	Long	No
1901.07	Memory wrong!	Wrong counter values. The unit will automatically repair itself	0	0	1	0	AUTO R.	Read only	3	Long	No
1902.08	Discharge sensor error	Indicates no signal from temperature sensor	0	0	1	0	AUTO R.	Read only	3	Long	No
1902.09	Suction sensor error	Indicates no signal from temperature sensor	0	0	1	0	AUTO R.	Read only	3	Long	No

Register	Parameter Name	Description	User Level	Min Value	Max Value	Default Value	Unit/ Type	Read/ Write	Modbus Function Code	Modbus Data Type	Persistent Yes/No
I/O CONFIGURATION											
ANALOG INPUTS											
1005	BPL-1/34	Pressure at the R452a suction line	2	-1.0	34.0	N/A	0-5 V	Read only	3	Short	No
1006	BPH-1/59	Condensing pressure of R717	2	-1.0	59.0	N/A	0-5 V	Read only	3	Short	No
1007	Dis. Temp	Measured discharge temperature of compressor	2	-50.0	170.0	N/A	PT1000	Read only	3	Short	No
1008	TempSuction	Measured suction temperature	2	-50.0	170.0	N/A	PT1000	Read only	3	Short	No
1009	NC Temp	Measured non Condensable gas temperature	2	-50.0	170.0	N/A	PT1000	Read only	3	Short	No
DIGITAL INPUTS											
1001.08	Status KL1	Compressor status (KL01) 0: Compressor off 1: Compressor on	2	0	1	1	N.O.	Read only	3	Short	No
1001.09	On/Off	Main switch input 0: Main switch off 1: Main switch on	2	0	1	1	N.O.	Read only	3	Short	No
1001.10	General Alarm	General Alarm input	2	0	1	0	N.O.	Read only	3	Short	No
1001.11	LiquidAlarm	Liquid Alarm input	2	0	1	0	N.O.	Read only	3	Short	No
DIGITAL OUTPUTS 0 = OFF ; 1 = ON											
1003.08	Compressor	Compressor relay	2	0	1	N/A	N.O.	Read only	3	Long	No
1003.09	Valve	Main purge valve relay	2	0	1	N/A	N.O.	Read only	3	Long	No
1003.10	Green	Status LED	2	0	1	N/A	N.O.	Read only	3	Long	No
1003.11	Yellow	Status LED	2	0	1	N/A	N.O.	Read only	3	Long	No
1003.12	DO_Red	Status LED	2	0	1	N/A	N.O.	Read only	3	Long	No
1003.13	ICFD_Valve	ICFD relay (solenoid valve)	2	0	1	N/A	N.O.	Read only	3	Long	No
1003.14	Valve1	Purge point valve relay	2	0	1	N/A	N.O.	Read only	3	Long	No
1003.15	Valve2	Purge point valve relay	2	0	1	N/A	N.O.	Read only	3	Long	No
1003.00	Valve3	Purge point valve relay	2	0	1	N/A	N.O.	Read only	3	Long	No
1003.01	Valve4	Purge point valve relay	2	0	1	N/A	N.O.	Read only	3	Long	No
1003.02	Valve5	Purge point valve relay	2	0	1	N/A	N.O.	Read only	3	Long	No
1003.03	Valve6	Purge point valve relay	2	0	1	N/A	N.O.	Read only	3	Long	No
1003.04	Valve7	Purge point valve relay	2	0	1	N/A	N.O.	Read only	3	Long	No
1003.05	Valve8	Purge point valve relay	2	0	1	N/A	N.O.	Read only	3	Long	No
1003.06	Alarm	Alarm relay	N/A	0	1	N/A	N.C.	Read only	N/A	N/A	N/A

**Maintenance/Service/
Disposal**

**Table 05
Maintenance checklist - Perform once a year minimum**

1	Use P&I diagram and check that all powered components are working properly
2	Check for alarms in the MCX controller
3	Fans, air filters and fins must be cleaned for dirt and dust
4	Expansion valve must be inspected and must be replaced if damaged
5	Ensure expansion valves sensor bulb has good contact with suction line
6	Replace water in water bubble bath. Check pH level frequently and replace when pH > 12.6
7	Check cover is mounted correctly and all bolts are tightened accordingly
8	Check and verify the amperage of the unit
9	Check for abnormal compressor noises in normal operating conditions (may indicate loose bolts, worn bearings or pistons)

**Table 06
Procedure to isolate IPS for servicing**

	Multipoint	Single point purging from receiver
1	Close all supply lines from the purge points of the ammonia system. Do not close any stop valve between IPS 8 and float valve	Restart the controller to force pump-down
2	Restart the controller to force pump-down	Wait 20 minutes
3	Wait 20 minutes	
4	Stop the compressor by turning the compressor switch QM1 to the off position	Stop the compressor by turning the compressor switch QM1 to the off position
5	Close the SVA shut-off valve in the drain line (located under the IPS 8)	Close the SVA shut-off valve in the drain line (located under the IPS 8)
6	Release the remaining system pressure to atmosphere by opening the SNV drain valve. This can also be done by attaching a permanent magnet on the AKVA 10 valve for forced opening	Release the remaining system pressure to atmosphere by opening the SNV drain valve. This can also be done by attaching a permanent magnet on the AKVA 10 valve for forced opening

Disposal of the IPS 8

If an IPS 8 unit is worn out and has to be replaced, the disposal must be done in accordance with national legislation and only done by competent personnel.

ENGINEERING
TOMORROW

The Danfoss logo is a stylized, cursive script of the word "Danfoss" in white, set against a red rectangular background.