

White paper

Communication protocols for wired digital sensor interfaces



Executive summary

This is the second white paper in a series addressing how industrial sensors are impacted by digitalization and the evolution around Industry 4.0. The first white paper, *Smart Sensor Connectivity of Tomorrow*, unpacks the drivers behind digital sensors across major industries—and what we can expect from digital sensor innovations in the future.

[Read it here](#)

Digital communication protocols play an increasingly important role in industrial automation. The rapid evolution of new technologies combined with digitalization have enabled major industries to achieve greater efficiency, optimization, and safety. Meanwhile, varying industry trends and standards, new application requirements, and the Industry 4.0 boom has led to new possibilities in expanding more advanced communication capabilities all the way down to the sensor and actuator level.

While analog sensors are considered to be the dominant solution in many industries today, new digital smart sensors are helping to pave the road to optimization by collecting, converting, and processing data. By understanding the different types of application communication systems, it is possible to integrate new smart features on the sensor side—creating added value and opening up entirely new opportunities across many applications.

Overall, the new sensor system architecture—based on layers within the Internet of Things (IoT)—shows us that different types of communication protocols can enable digital sensors to find new ways of passing data along to a system. In this paper, we focus on the wired connectivity of industrial sensors—in other words, how a sensor transfers data and connects to the application or system.

You will **learn about**

1. Digital sensor connectivity
2. Drivers behind digital sensor communication
3. Examples of sensor usage within wired digital communication
 - a. Low-level digital communication
 - b. Fieldbus communication
 - c. Industrial Ethernet
4. Conclusion

1. Digital **sensor connectivity**

As already stated, sensor interfaces can be divided into two categories: analog and digital.

Analog output: A wide range of standardized analog outputs are still in use depending on the industry and application, with the most common ones being 4-20 mA, ratiometric voltage, and various absolute voltage types. In these examples, the sensor output value is proportional to the analog sensor output signal, which typically is the only information the sensor transmits.

Digital communication: A digital sensor has an embedded digital communication protocol on top of internal microprocessor-based electronics. This design allows for more sophisticated communication between the sensor and the application interface to establish and access new features that optimize performance and efficiency.

When specifying sensors for digital communication protocols, the following high-level specification areas should be considered:

- Uni- or bi-directional communication
- Data transmission: the amount of data to be transmitted
- Baud rate: the communication speed
- Wiring: peer-to-peer, multidrop (bus), or wireless solutions
- Scalability: master/slave setup, amount of possible network nodes

2. Drivers behind digital sensor communication

Digitalization and connectivity have set the pace for Industry 4.0. Now customers increasingly demand and expect the reliability and transparency provided by digital solutions, such as diagnostics, data handling, and the ability to leverage smart sensors for configuration and control. Before we dive into the different types of sensors, we will first shed light on some of the drivers and benefits in switching from an analog to a digital sensor solution.

In short, some of the drivers for going digital on the sensor communication side are:

1. Access to additional data/information from the sensor
2. Simplification of the wire harness at the edge/application
3. Free up analog I/O's at the edge/application
4. Unique sensor identification (poka-yoke)
5. Smart configuration of the sensors via digital communication interface

While there is a huge potential to gain these benefits from digital sensor communication, it depends heavily upon the system a sensor is installed in and how it is used—in other words, it depends upon the overall system architecture. Therefore, it is important to know that there are different cases for both analog and digital sensors.

When looking at the new sensor system architecture, we can see that the different types of communication protocols can create new ways of passing valid information to the system—and in some cases, even to higher system layers.

The sensor system architecture

This diagram refers to the seven layers of IoT—and how it links to the different communications and interfaces in a typical industrial system architecture.

Layer 6+7 – Applications and presentation

Using “things” data, decisions based on processed data, visualization of learnings

Layer 4+5 – Big data & Analytics

Harvest and storage of data, data analysis, reporting, data mining, machine learning

Layer 3 – Global infrastructure

Cloud infrastructure

Layer 2 – Connectivity and Edge Computing

Communications, protocols, networks, M2M, controls

Layer 1 – Physical layer / “things”

Sensors, actuators, devices

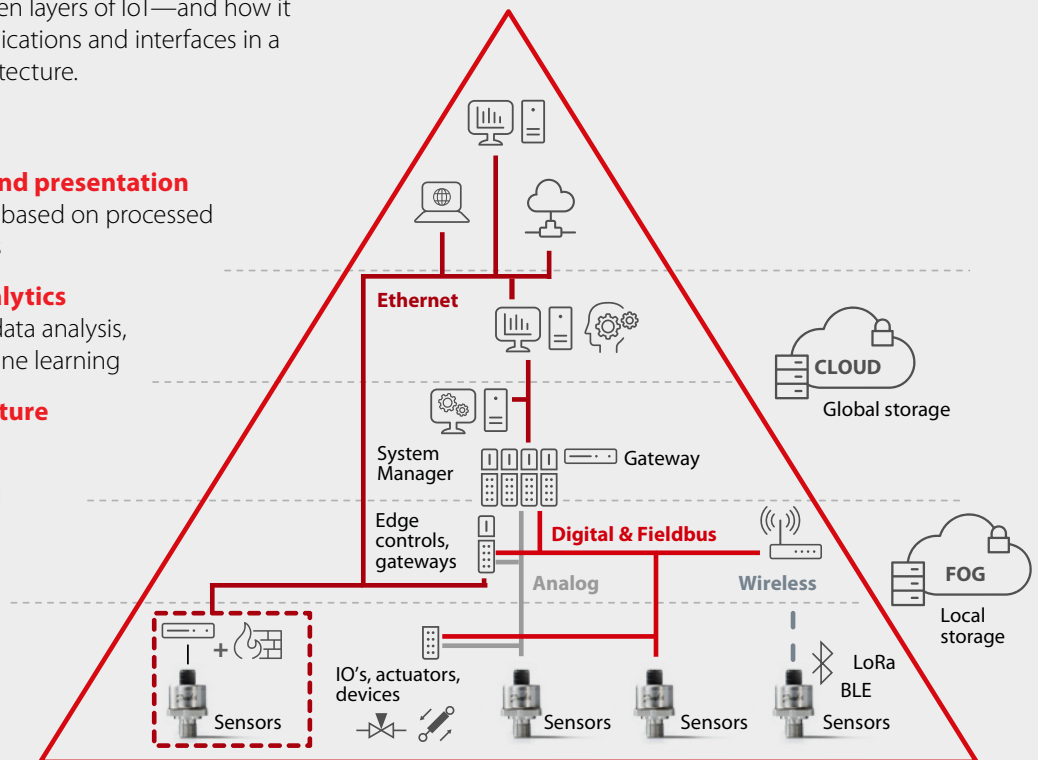

3. Examples of sensor usage within **wired digital communication**

While digital sensor communication can be divided into wired or wireless solutions, in this paper, we focus on wired solutions—which can be divided into three main categories:

a. Low-level digital communication (Primarily IoT layer 1)

- SENT SAE J2716 protocol
- HART protocol
- I²C/SPI protocols

b. Fieldbus communication (IoT layers 1 and 2)

- CAN (CAN open, CAN SAE J1939, CAN FD) protocols
- Modbus RTU protocol
- IO-Link protocol
- BACnet MS/TP protocol

c. Industrial Ethernet (IoT layers 1–7)

- 10Mb/s Single Pair Ethernet (10-SPE) protocols

a) **Low level digital communication**
(Primarily IoT layer 1)

SENT SAE J2716 Protocol

Single Edge Nibble Transmission (SENT) is a unique serial interface designed originally for the automotive industry. However, it can also be relevant for other industry segments due to its value proposition, low cost, and simple receiver interface.

The SAE J2716 SENT protocol is a unidirectional point-to-point scheme for transmitting signal values from a sensor to a controller and requires a three-wire interface solution (Vsup, GND, output). This protocol allows for the transmission of high-resolution data with a low system cost.

The SENT protocol consists of a fast channel part that transmits real-time measurement data, supporting most application response time requirements demanded in the field today. A serial communication message sends additional sensor data to the receiver, such as specific part information, diagnostics, complementary sensor measurement information, and other proprietary customer data.

In SENT communication, data is transmitted in units of four bits, referred to as a nibble. A nibble is defined by the time distance between two falling edges, used to evaluate the nibble value in the data transmission string.

As mentioned, each SENT message contains time-critical “fast channel” sensor measuring data. The serial data message is used to transmit less time-critical data and consists of data information from 18 consecutive SENT messages. In each of the 18 SENT messages, two bits of the Status/Communication nibble are dedicated to the serial data message information.

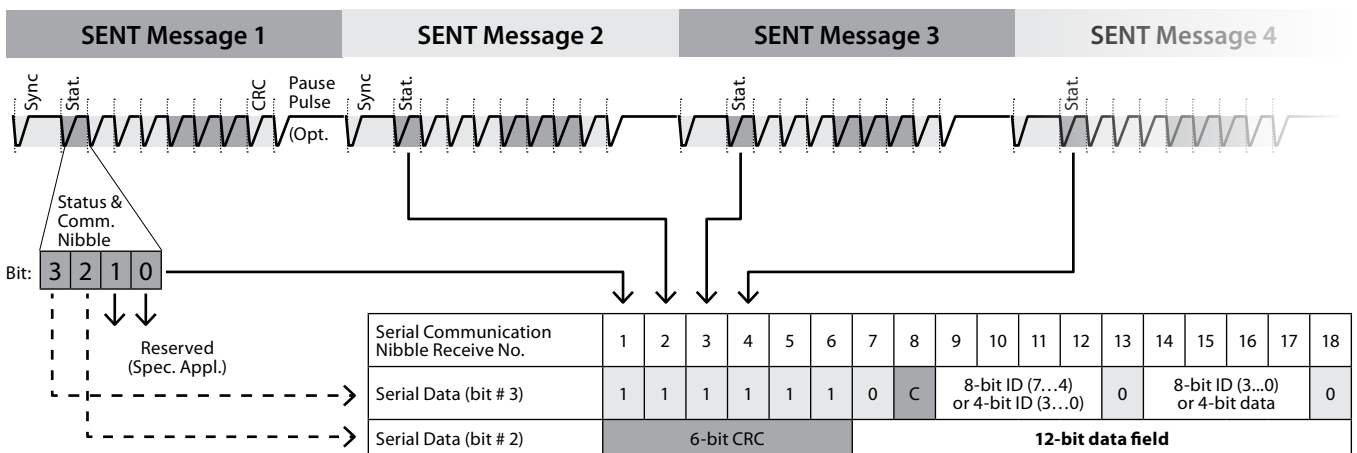

One serial message is composed of 18 SENT consecutive error-free messages.

HART Protocol

The Highway Addressable Remote Transducer (HART) protocol is a global standard for sending and receiving digital information across analog wires—connecting smart devices with control or monitoring systems. In other words, HART is a digital communication protocol layered on top of a traditional analog 4-20mA signal—providing more communication capabilities for advanced data retrieval and remote configuration options.

For example, in a field device such as a sensor, the 4-20mA signal communicates the primary measurement value using the 4-20mA current loop—one of the fastest and most reliable industry standards for analog sensors. Additional device or application information is communicated using a digital signal superimposed onto the analog signal.

The digital signal typically contains information from the device, including device status, diagnostics, and additionally measured or calculated values. Together, the two communication channels provide a cost-efficient, robust, complete field communication solution that is easy to use and configure.

a) Analog + Digital communication:

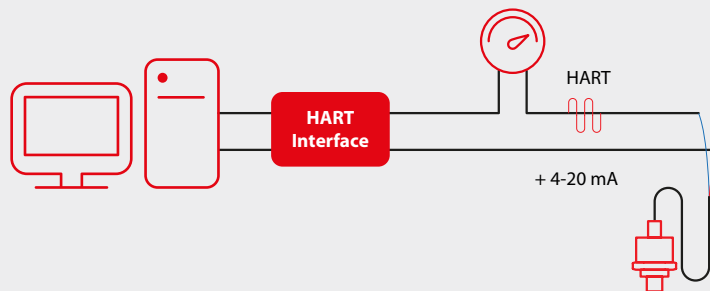

b) Digital communication only:

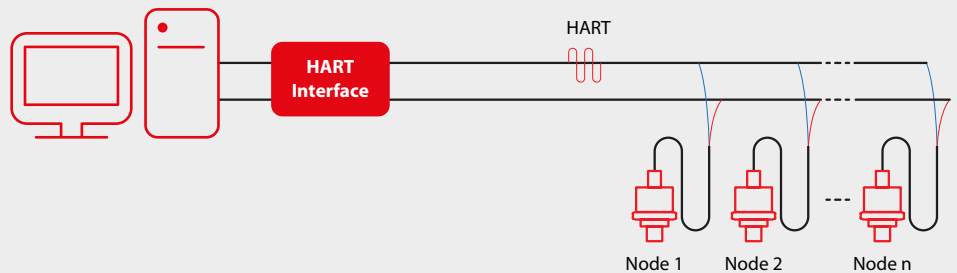

HART is a two-wire master/slave protocol, where the smart sensor (slave device) only speaks when spoken to by a master. The HART protocol provides a bi-directional communication interface that can be used in two configurations. One possibility is a point-to-point setup used for running a 4-20 mA analog output in combination with the digital HART protocol. The alternative could be to run a multidrop installation where all communication is based on the digital HART protocol.

The baud rate of the digital communication channel is 1,200 bits per second (baud). A multidrop installation is limited to a maximum of 15 devices—typically suitable for sub-control applications in distributed control systems (DCS) where HART today is among the preferred communication protocols.

I²C and SPI Protocols

I²C and SPI are serial communication protocols typically used in embedded sensor solutions in many applications. Both are bi-directional, synchronous protocols, meaning the output is synchronized to the sampling of bits by a clock signal shared between the master and the slave. SPI is a four-wire full-duplex protocol, whereas I²C is a two-wire semi-duplex protocol.

Both protocols are used for short-distance serial data transfer (max. one meter) and found in inter-controller/processor communication, EEPROM, ADC, and other real-time communication applications. Many modern microcontrollers have I²C and/or SPI interfaces—making the protocol highly suitable for internal communication in embedded systems.

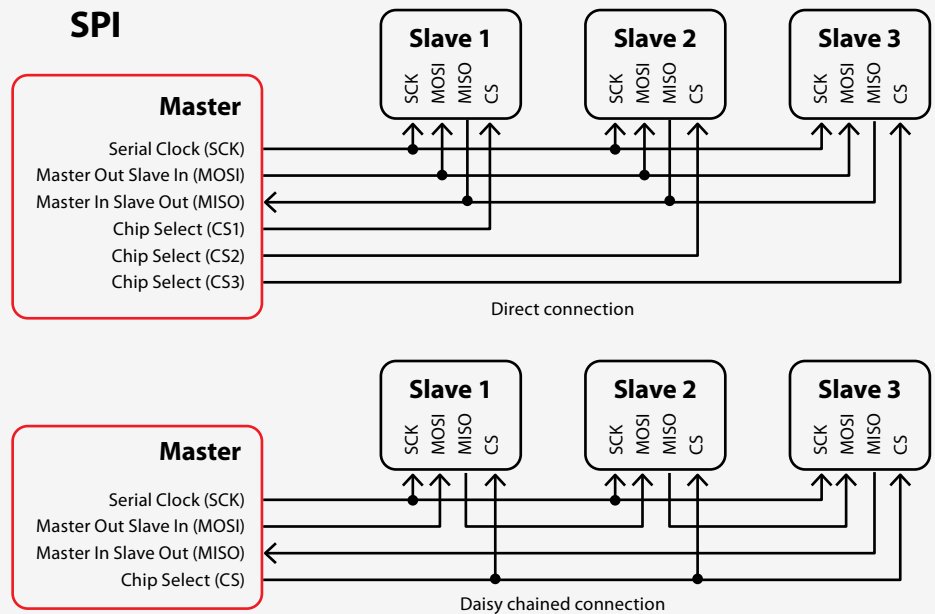
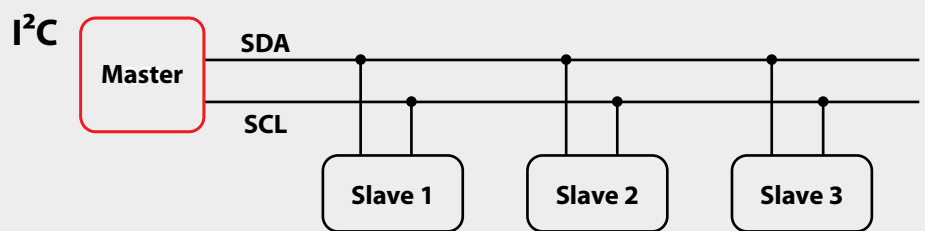

There are two configurations for multi-slave interfacing in the SPI protocol: a direct connection or a daisy-chained connection. The direct connection uses a chip select (CS) line for each slave device. In most cases, this can support up to three slave devices depending on the CS interface on the master unit. A daisy chain connection comes into play if a design requires more than three devices on the bus. In this case, a common CS supports multiple slave devices, and data is streamed on a common data line.

I²C uses two wires for communication: one for data and the other for the clock. It uses 7 bits for device addressing, enabling it to support up to 128 devices (0 to 127). The two-wire concept makes the I²C less expensive than SPI—the trade-off being a choice between cost and data transfer rate.

b) **Fieldbus communication**
(IoT layer: 1 and 2)

CAN Bus Protocols

A Controller Area Network (CAN bus) is a robust vehicle bus standard designed to allow microcontrollers and devices to communicate with each other's applications without a host computer.

From a sensor point of view, there are three general CAN network protocols: CANopen, CAN FD, and CAN SAE J1939. The CANopen and CAN J1939 standards share the same physical layer (ISO11998), but different data frame formats and protocols are used. CAN FD is an updated data link layer which can run with higher data rates.

In general, CAN is a peer-to-peer message-based protocol that can use multiple baud rates; CANopen and CAN J1939 support baud rates up to 1 Mbit/s, whereas CAN FD supports up to 5 Mbit/s during data transmission. The most common baud rates for sensor applications are 125 kbit/s (CANopen), 250 kbit/s (J1939), and up to 2 Mbit/s (CAN FD).

The main advantages of using CAN as a field-bus technology are:

- Reduced wiring (the CAN bus requires only two wires between nodes)
- Extremely reliable communication
- Easy implementation
- Improved maintenance and service

All of which produce better vehicle/application performance while reducing production costs.

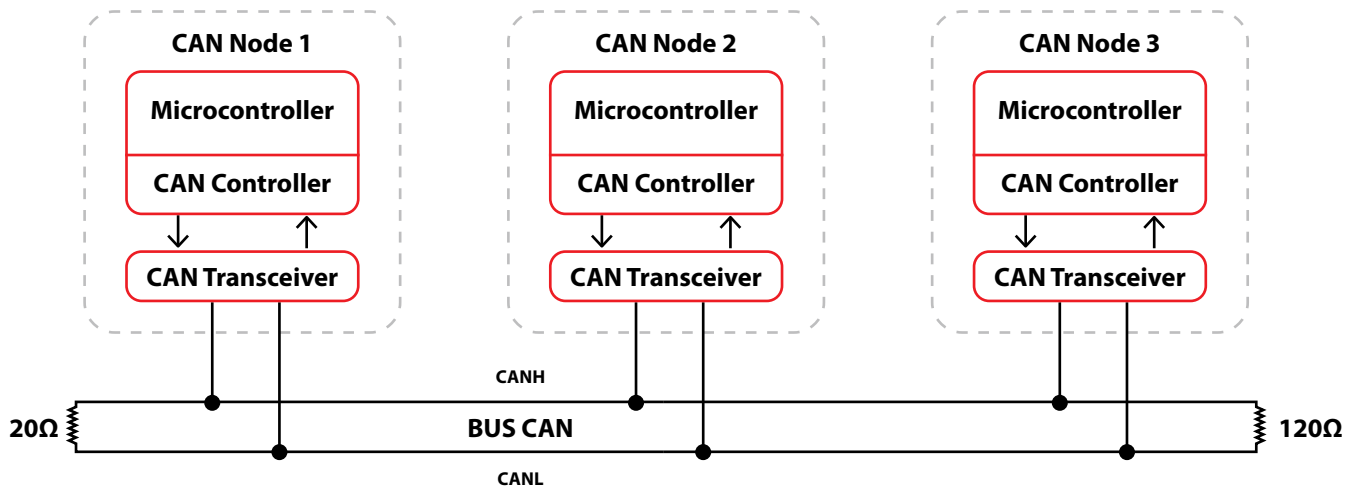

CANopen: CANopen is a standardized and flexible high-level communication protocol whose unique node address scalability can handle up to 127 nodes and can transmit up to 8 bytes in the datafield of each message. The CANopen profile family specifies standardized communication mechanisms and device functionalities.

Originally developed for embedded network applications focused mainly on in-vehicle networks, today, the CANopen protocol is widely used in other industrial applications, becoming a popular choice for closed, company-specific embedded networks.

CAN FD: The CAN FD communication protocol retains the core features of CANopen while adding two advanced features:

- Up to five times faster transmission speed in the data field (Note: the bit rate is still limited to 1 Mbit/s during arbitration and acknowledgment of the CAN FD frame)
- Increase the data payload up to 64 bytes

CAN FD is typically an excessive communication protocol for smart sensors since most relevant applications require much less data throughput and lower transmission rates. In some cases, however, it is a requirement for compatibility reasons. For example, if a receiver controller interface operates on an existing CAN FD protocol for communication with other devices, then a smart sensor being added to the network must support the same protocol.

CAN SAE J1939: CAN J1939 is the trimmed and optimized communication protocol positioned mainly for the automotive industry—and is also commonly used in mobile hydraulic applications.

SAE J1939 uses CAN (ISO11998) as the physical layer: it is a recommended practice that defines which and how data is communicated between the Electronic Control Units (ECU) within a vehicle network. Typical controllers are the engine, brake, transmission, and so on.

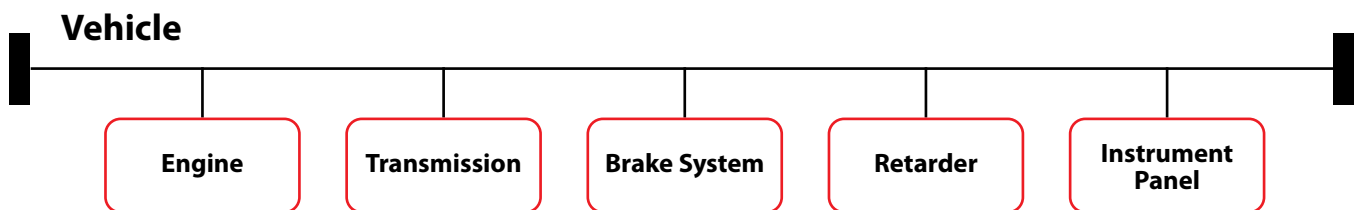

Most messages defined by the J1939 standard are intended to be broadcasted, meaning that data is transmitted on the network without a specific destination. This permits any device to use the data without requiring additional request messages, enabling future software revisions to easily accommodate new devices (address assignments).

When a message must be directed to a particular device, a specific destination address can be included within the message identifier. For example, a request for a specific torque value from the engine instead of a specific torque value from the brake controller.

Its scalability in terms of unique node addresses can handle up to 253 nodes and can transmit up to 8 bytes in the datafield of each message.

Modbus RTU Protocol

Often referred to as the granddaddy of industrial communication protocols, Modbus RTU is a fieldbus communication system built on a relatively simple serial protocol requiring a 4-wire communication interface (and optional shield).

In this setup, it can support a full-duplex communication. The protocol can be transmitted via traditional UART technology, utilizing the RS485 serial data transmission standard.

RS 485 / Modbus RTU

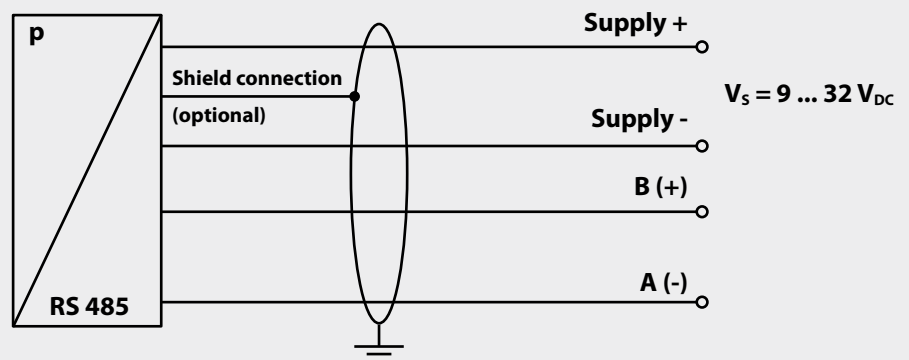

The Modbus protocol demands low process and RAM requirements on the receiver side. Data is transmitted in 8-bit bytes, one bit at a time, at baud rates ranging from 1,200 bits per second (baud) to 115,200 bits per second. Modbus RTU has excellent scalability as it can handle up to 247 nodes.

Widely used in building management and industrial automation systems, the Modbus protocol can now be extended to the smart sensor level, providing new value propositions:

- Simplified, scalable daisy-chain wire harness
- Specific part information
- Diagnostics
- Proprietary customer/application data

IO-Link Protocol

IO-Link is a bi-directional digital protocol: it is not a fieldbus but a point-to-point communication between an IO-Link master and one or several IO-Link devices (typically digital sensors and actuators).

In factory automation applications where there is stationary production equipment, sensors and actuators are crucial components for monitoring and controlling applications—and IO-Link is among the most commonly used protocols for such applications.

The IO-Link environment provides plug-and-play scalability and a framework to implement new applications and devices easily. Furthermore, it is a low-cost solution on the cable and connector side, as it does not require expensive shielded cables.

An IO-Link master can support three transmission (baud) rates:

- 4.8 kbits/s
- 38.4 kbits/s
- 230.4 kbits/s

And an IO-Link device only has to support one of the three baud rates.

In a factory, the PLC system often consists of high-level fieldbuses. That means the IO-Link master maps the data exchange between the IO-Link device and the PLC to fit the utilized fieldbus communication—enabling bidirectional communication. Specification already exists for IO-Link mapping for PROFIBUS, PROFINET, INTERBUS, AS-I, EtherCAT, and PowerLink.

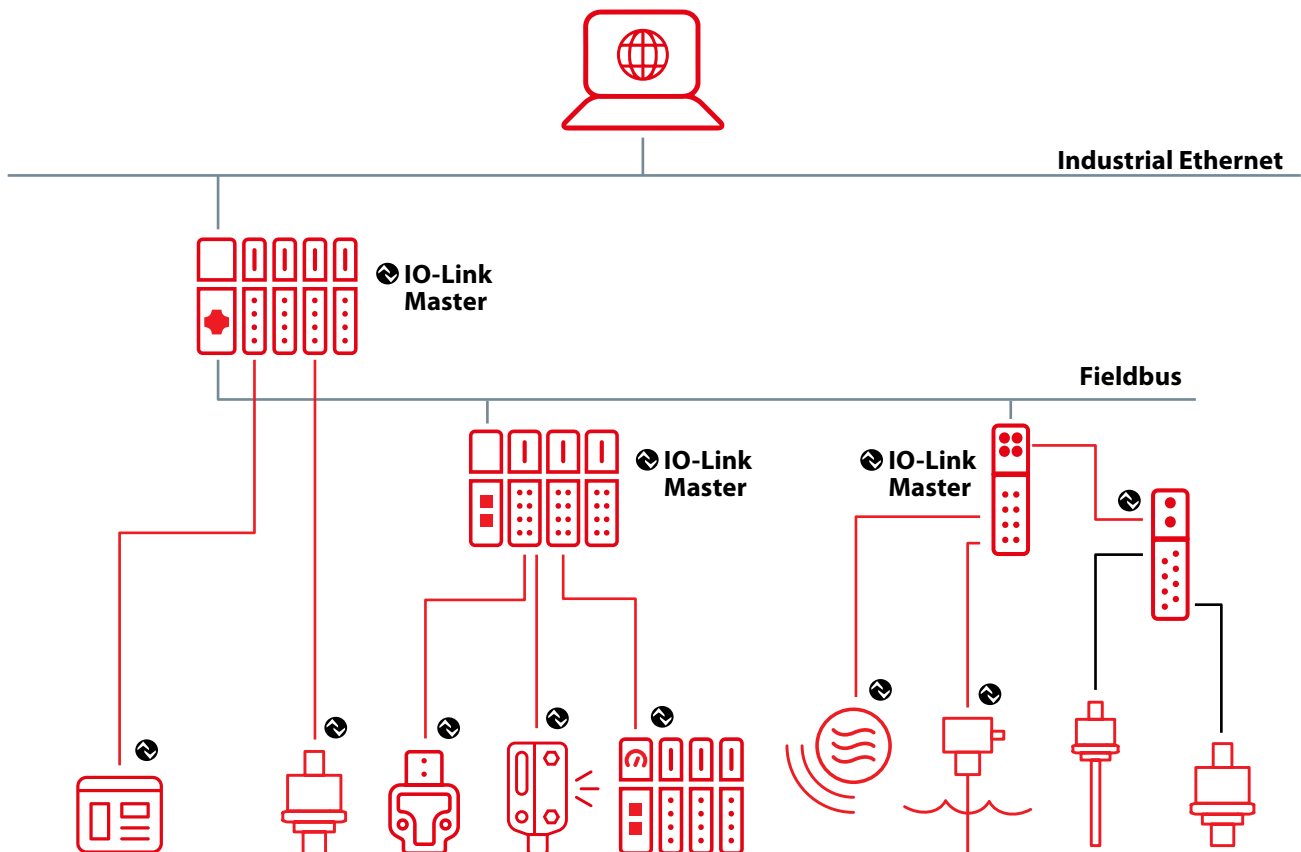

BACnet MS/TP Protocol

BACnet is a data communications protocol used in building automation systems (BAS) to support the communication and control of HVAC, lighting, access control, fire detection applications, etc. It is an approved and standard protocol by the American Society of Heating, Refrigerating and Air Conditioning Engineers (ASHRAE) and the ANSI and ISO standardization authorities.

The BACnet MS/TP is a bi-directional protocol that uses RS-485 as the physical layer standard for data transmission. Devices must be wired in a daisy chain configuration, with one main cable where every network device is connected along its path. It supports a semi-duplex communication with a two-wire communication interface (plus an optional shield), offering a simple, low-cost way to connect devices within BAS networks.

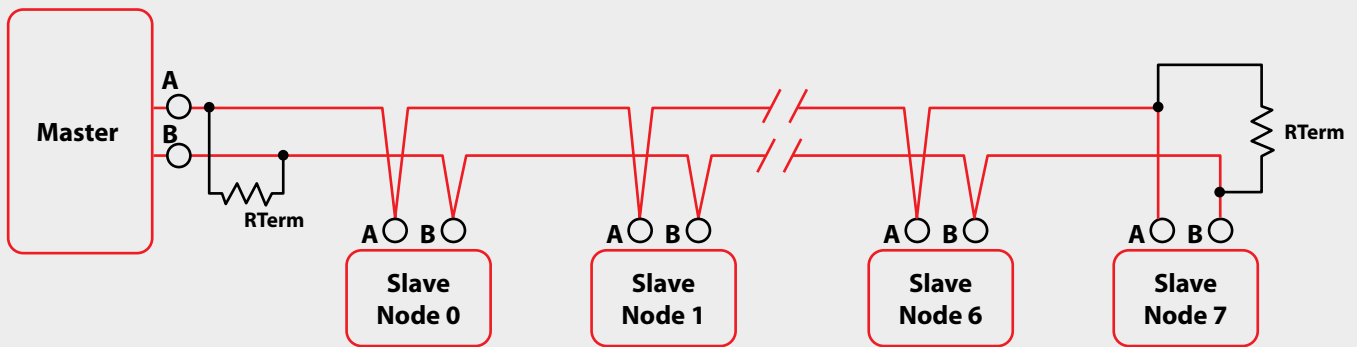

(Illustration without shielded-cable use)

BACnet supports a wide range of baud rates, ranging from 9.6 kbit/s up to 115 kbit/s. The maximum number of master devices on one data bus segment is 127, which provides a good scalability.

c) **Industrial Ethernet**
(IoT layer: 1-7)

10Mb/s Single Pair Ethernet (10-SPE) Protocols

Ethernet is gaining traction as a fieldbus alternative in industrial system environments because of the simplified and seamless networking it provides in all application layers.

10-SPE is a low complexity and a low bandwidth communication protocol—that means it is suitable for expanding Ethernet communication all way down to the sensor and actuator level. The 10-SPE standard provides sensors and actuators with a unified communication protocol and a common networking infrastructure, providing cost-effective, plug-and-play simplicity down to the PHY layer. This particular Ethernet solution runs with a 10 Mb/s baud rate and is based on a simple, two-wire solution.

Both sensor technology and use cases are evolving rapidly in automotive, industrial, and process applications—that's why embedding digital communication capability into the sensor is a vital component to embracing the Industrial Internet of Things. Because of its lean profile, 10-SPE can enable a new class of low-power devices that will ultimately facilitate the networking and powering of billions of sensors in the years to come.

The same software stack and communication mechanisms are used for all IoT layers when using an Ethernet architecture in an entire system—only the PHYs and cables must be changed to accommodate the particular speed and bandwidth grade of each layer.

Consider this example on Ethernet scalability and complexity from the automotive industry:

- 1000BASE-T1 for backbone and infotainment
- 100BASE-TX for diagnostics and software downloads
- 10BASE-T1S/T1L for the car body and powertrain communications

In this case, 10-SPE replaces the need for CAN, CAN FD, LIN, Flexray, and similar communication systems—significantly reducing the overall system complexity.

When it comes to smart sensor applications, a key feature of 10-SPE is that it enables a simultaneous power supply of terminal devices via a Power over Data Line (PoDL). Traditionally, that setup requires two additional pairs for Fast Ethernet (e.g., 100MB) and four additional pairs for Gigabit Ethernet (1GB). 10-SPE with PoDL creates entirely new possibilities and relevant applications for Industrial Ethernet.

The two 10-SPE variants in focus for sensors are:

- **10BASE-T1L:** A full-duplex solution based on point-to-point communication suitable for both short and long distances (up to 1000m).
- **10BASE-T1S:** A half-duplex solution based on point-to-point communication suitable for short distances (up to 25m) that supports a multidrop Ethernet architecture as well. However, this variant does not yet support PoDL. To control the communication in a multidrop setup, T1S uses Physical Layer Collision Avoidance (PLCA) to avoid collision and corrupted data transfer by only allowing one node to transmit data during each transmission opportunity.

Both are part of the SPE standard IEEE 802.3cg

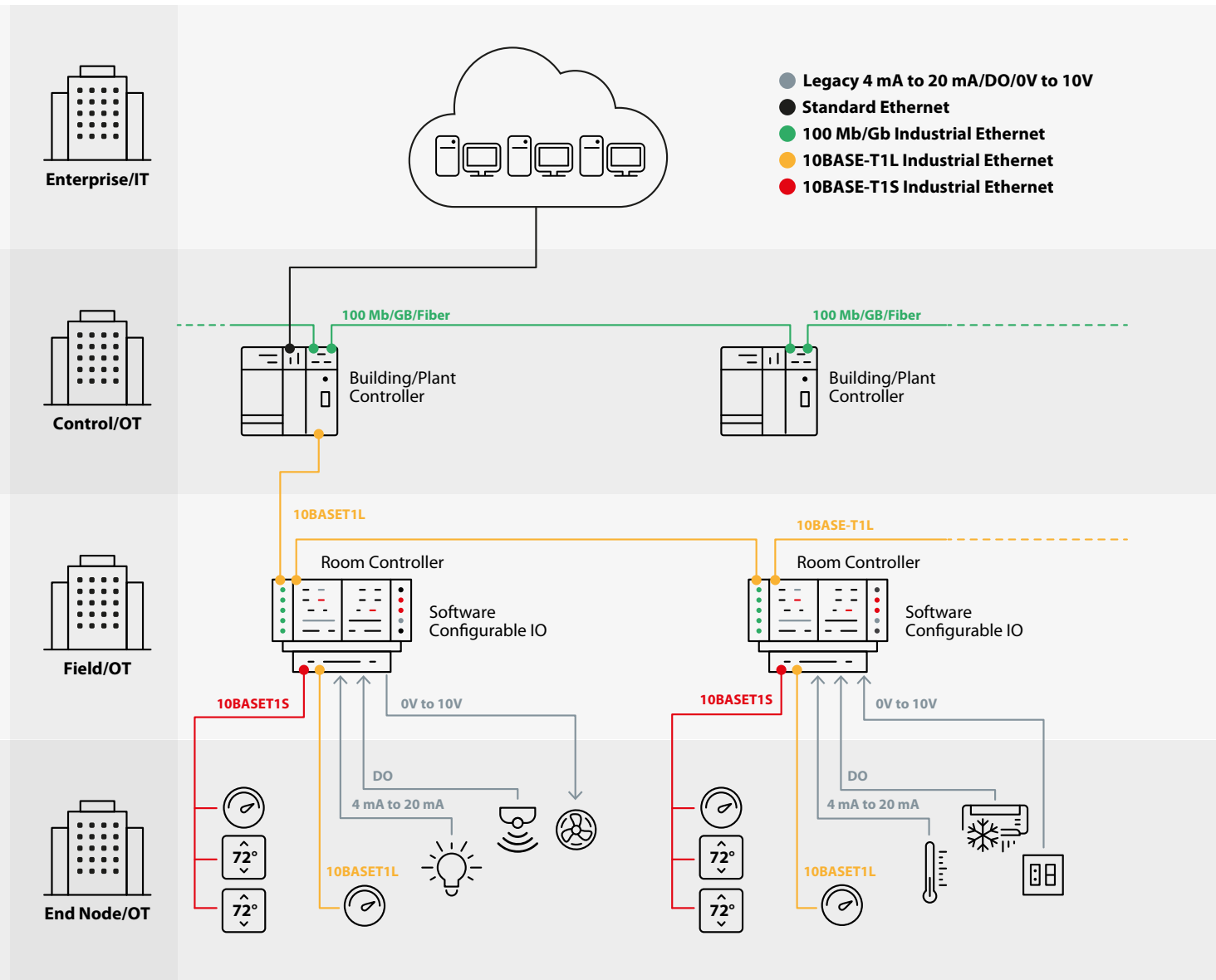

Protocol	Communication type	Typical baud rates used for sensor applications	Wiring setup	Power supply	Number of conductors	Cable Length	Typical Industries
SENT	Uni-directional (node to master)	Typical 30 kbit/s	P2P	5 Vdc	3 wire	5 m	<ul style="list-style-type: none"> Automotive Mobile hydraulics Industrial Engines
I ² C and SPI	Bi-directional I ² C: semi-duplex SPI: full-duplex	Given by the frequency of the shared clock signal between the master and slave. Short distance (<10 cm): Mbit/s range. For most sensor app: <100 kbit/s is sufficient.	I ² C: bus SPI: P2P, Daisy chain	Typical 2.7-5.5 Vdc	I ² C: 2 wire SPI: 4 wire	Max 1m	Embedded sensor solutions in various applications
HART	Bi-directional, Semi-duplex	1.2 kbit/s	P2P or multidrop	Typical 9-32Vdc for sensor app.	2 wire	>1500 m	<ul style="list-style-type: none"> Industrial automation Chemical industry Marine Gas & Oil
Modbus RTU	Bi-directional, full-duplex	Up to 115.2 kbit/s Typical baud rates used for sensor app: 9.6 or 19.2 kbit/s	Bus	Typical 9-32Vdc for sensor app.	2 wire	Up to 1200 m (depending on baud rate)	<ul style="list-style-type: none"> HVAC Air compressors Industrial Pump applications
CANopen	Bi-directional, Semi-duplex	Typical 125 kbit/s	Bus	Suitable for 12V and 24V systems.	2 wire	Depending on number of nodes and baud rate 50 kbit/s up to 1000 m 125 kbit/s up to 500 m	<ul style="list-style-type: none"> Invehicle networks Industrial automation Industrial applications
CAN FD	Bi-directional, Semi-duplex	Typical 2 Mbit/s	Bus	Suitable for 12V and 24V systems.	2 wire	Depending on number of nodes and baud rate 50 kbit/s up to 1000 m 125 kbit/s up to 500 m 250 kbit/s up to 250 m 500 kbit/s up to 100 m 1 Mbit/s up to 25 m	<ul style="list-style-type: none"> Invehicle networks Industrial automation Industrial applications
CAN SAE J1939	Bi-directional, Semi-duplex	Typical 250 and 500 kbit/s	Bus	Suitable for 12V and 24V systems.	2 wire	Depending on number of nodes and baud rate 50 kbit/s up to 1000 m 125 kbit/s up to 500 m 250 kbit/s up to 250 m	<ul style="list-style-type: none"> Automotive industry Mobile hydraulic
IO-Link	Bi-directional, Semi-duplex	4.8 kbit/s, 38.4 kbit/s and 230.4 kbit/s	P2P	Typical 9-32Vdc for sensor app.	2 wire	Typical up to 20 m	<ul style="list-style-type: none"> Industrial automation Factory automation
BACnet MS/TP	Bi-directional, Semi-duplex	Up to 115 kbit/s	Bus	Typical 18-30Vdc for sensor app.	2 wire	Up to 1200 m (depending on baud rate)	<ul style="list-style-type: none"> Building automation (BAS) HVAC
10BASE-T1L	Bi-directional, full-duplex	10 Mbit	P2P (utilizing PoDL)	SPE PoDL for power sourcing equipment: compatible with 12V (regulated/unregulated), 24V (regulated/unregulated), and 48V (regulated)	2 wire (in a PoDL setput)	1000 m (2.4 V) with up to 10 joints (terminal boxes)	<ul style="list-style-type: none"> Automotive industry Building automation (BAS) HVAC Robotics
10BASE-T1S	Bi-directional, Semi-duplex	10 Mbit	Daisy chain, P2P	Application specific	2 wire (seperate power supply might be needed)	25m	<ul style="list-style-type: none"> Building automation (BAS) HVAC

4. Conclusion

Sensors have played an important role in industrial controls for decades—and their evolution is directly linked together. Industry 4.0 and the Industrial Internet of Things (IIoT) have driven a sensor’s ability to help automate applications, optimize processes, increase safety, and achieve greater efficiency than ever before.

And there is more to come. New measuring points and types of application data combined with the overall need for more data will define smart solutions moving forward. Meanwhile, rapid technological development in communication systems has created completely new ways of embedding smart solutions and communication capabilities into small, low-cost devices.

The development of new sensor technologies within controls, monitoring, and IT is helping global industries meet demands for greater efficiency, safety, and optimization—and to do more with less. And so, understanding the different types of wired digital communication standards is critical to tapping into the full potential of smart sensor solutions—and preparing for the next wave of industrial evolution.

System architecture Sensor communication interfaces

- A. Low level digital communication (IoT layer: 1)
- B. Fieldbus communication (IoT layer: 1 and 2)
- C. Industrial Ethernet (IoT layer: 1-7)

- Layer 6+7 – Applications and presentation**
Using “things” data, decisions based on processed data, visualization of learnings
- Layer 4+5 – Big data & Analytics**
Harvest and storage of data, data analysis, reporting, data mining, machine learning
- Layer 3 – Global infrastructure**
Cloud infrastructure
- Layer 2 – Connectivity and Edge Computing**
Communications, protocols, networks, M2M, controls
- Layer 1 – Physical layer / “things”**
Sensors, actuators, devices

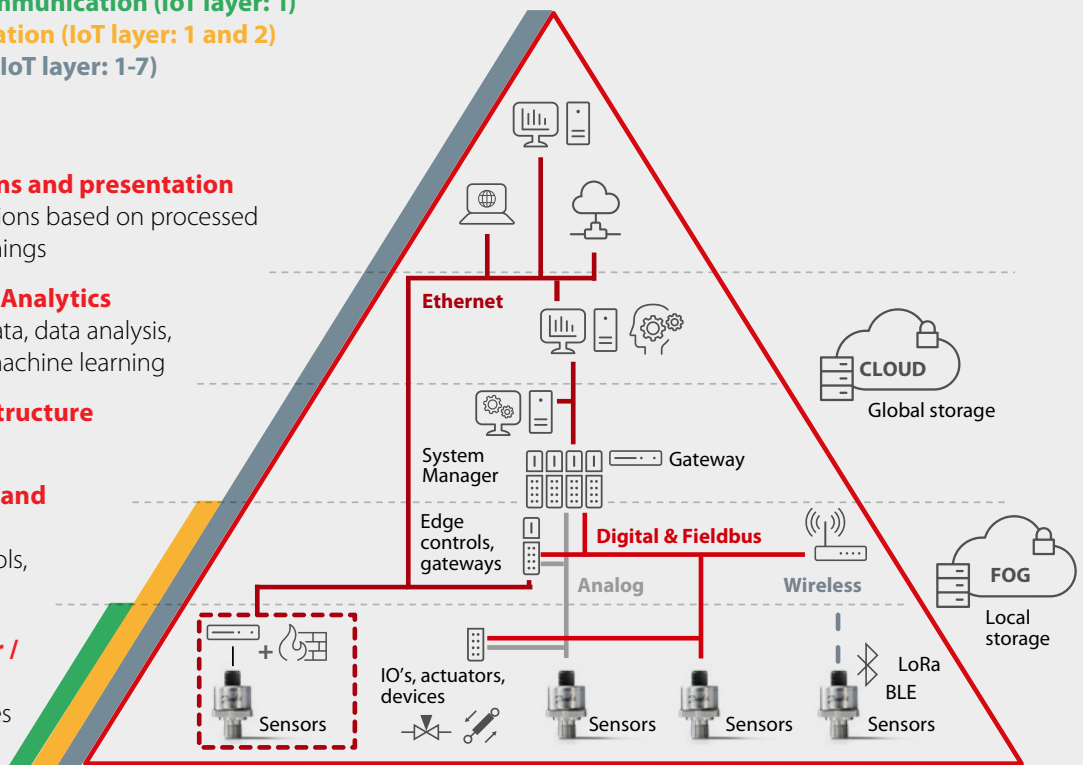



Embracing Smart Sensor technology to meet the challenges of tomorrow – today

Industrial innovation is a powerful force not only in business but in the evolution of our cities and the protection of natural habitats and precious resources. Smart sensor technology is the driving force behind the ability to optimize industrial processes, components, and machines to meet the growing demands for meaningful solutions.

From preventing water loss to optimized district heating solutions, smart sensors play a pivotal role in providing innovative solutions to prepare for a healthier, safer, and more productive tomorrow. Through greater accuracy and energy efficiency, primary industries can enable the sustainable growth of tomorrow's megacities.

Learn more at sensors.danfoss.com