

User Manual

# Remote Control MP20A Receiver

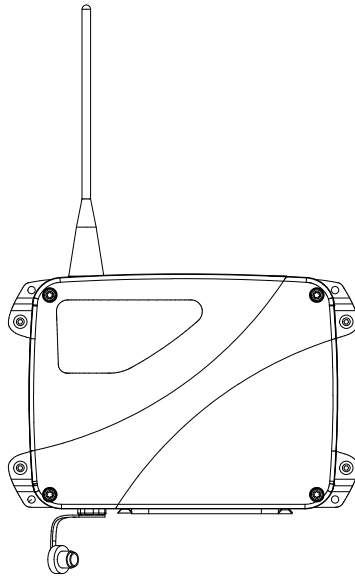

**Revision history**

*Table of revisions*

<b>Date</b>	<b>Changed</b>	<b>Rev</b>
March 2022	Updated safety instructions and technical descriptiono	0201
January 2019	Rebranded to Danfoss Power Solutions	0101

## Contents

### Safety instructions

FCC rules.....	4
General safety.....	4
Safety warnings.....	5

### Technical description

Dimensions.....	6
Hardware description.....	7
MP20A/MP20V detailed description.....	7

### Installation

Receiver installation.....	9
Input and output configuration.....	10
Digital outputs.....	10
Analog outputs.....	12
Pinout.....	13

### Troubleshooting

400 - 900MHz Receiver icon troubleshooting.....	14
2.4GHz Receiver Icon Troubleshooting.....	14

## Safety instructions

### FCC rules

This equipment has been tested and found to comply with the limits for a Class A digital device, pursuant to Part 15 of the FCC Rules.

---

Changes or modifications not expressly approved by the manufacturer can void the user's authority to operate the equipment.

---

To comply with FCC RF exposure compliance requirements, this device and its antenna must not be collocated with, or operating in conjunction with, any other antenna or transmitter, may not cause harmful interference, and must accept any interference received, including interference that may cause undesired operation.

---

The limits are designed to provide reasonable protection against harmful interference when the equipment is operated in a commercial environment. This equipment generates, uses, and can radiate radio frequency energy, and if not installed and used in accordance with the instruction manual, may cause harmful interference to radio communications.

Operation of this equipment in a residential area is likely to cause harmful interference in which case the user will be required to correct the interference at his own expense.

#### **Warning**

---

Le présent appareil est conforme aux CNR d'Industrie Canada applicables aux appareils radio exempts de licence. L'exploitation est autorisée aux deux conditions suivantes:

1. l'appareil ne doit pas produire de brouillage, et
  2. l'utilisateur de l'appareil doit accepter tout brouillage radioélectrique subi, même si le brouillage est susceptible d'en compromettre le fonctionnement.
- 

### MP20A General Safety

The following safety instructions must be read carefully to install and use the product properly, and to keep it in perfect working condition, and to reduce the risk of misuse.

- Strictly adhere to the installation instructions contained in this document.
- Make sure that professional and competent personnel carry out the installation.
- Ensure that all site and prevailing safety regulations are fully respected.
- Make sure that this document is permanently available to the operator and maintenance personnel.
- Keep the transmitter out of reach of non-authorized personnel.
- Remove the transmission key when the set is not in use.
- Check each working day the STOP button and other safety measures. When in doubt, press the STOP button.
- Whenever several sets have been installed, make sure the transmitter is the right one. Identify the machine controlled on the label for this purpose on the transmitter or by using the display (in case it has one).
- Service the equipment periodically.
- When carrying out repairs, use spare parts supplied by Danfoss only.

#### **Warning**

---

**Potential damage to the operator or the product.** Do not use this product on machines in potentially explosive atmospheres unless the model is ATEX/RATEX certified to work in such conditions.

---

## Safety instructions

### MP20A Safety Warnings

**Potential damage to operator and product.**

**Follow the guidelines below to reduce risk of injury to the operator and the product.**

- Use the device with the manufacturer's battery and battery charger (if applicable).
- Only allow qualified personnel to operate the equipment.
- Always set the STOP button in the off position when not in use.
- Always press STOP before plugging in tether cable (if applicable).
- Remove the Tether connection on the transmitter First (if applicable).
- Do not operate product when visibility is limited.
- Make sure product is compatible with the machine.
- Avoid knocking or dropping the product.
- Do not use the product if a failure is detected.

**Changes or modifications not approved by Danfoss can void the user's authority to operate this product.**

#### Quick reference precautions

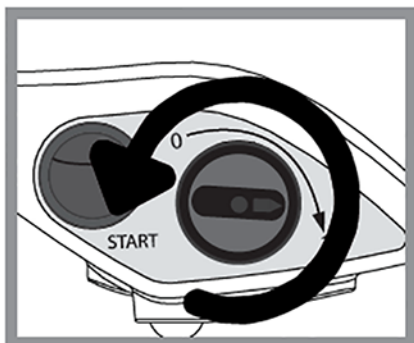

Remove the transmission key only when the set is not in use or to deny the access

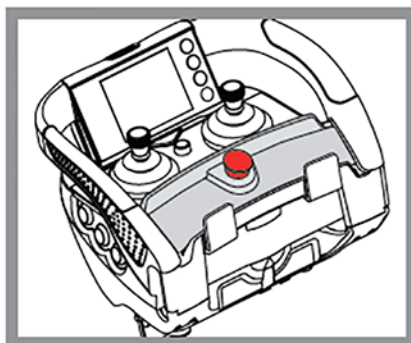

When in doubt, press the STOP button

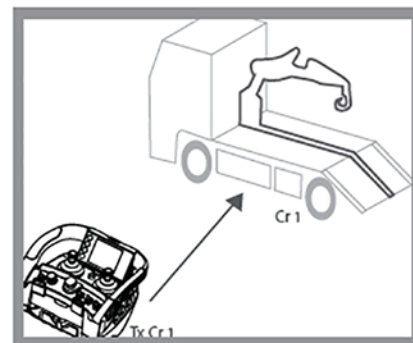

Make sure the transmitter works with the machine to be handled

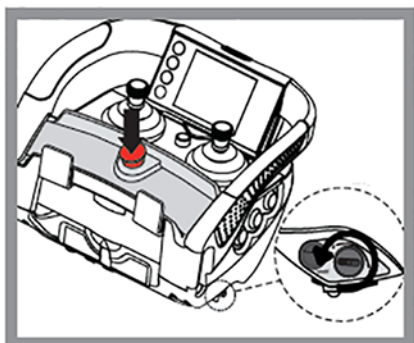

After use set the contact key and the STOP button



Do not use the set when visibility is limited



Avoid knocking or dropping the set

### Technical description

#### MP20 dimensions

*Dimensions in mm*

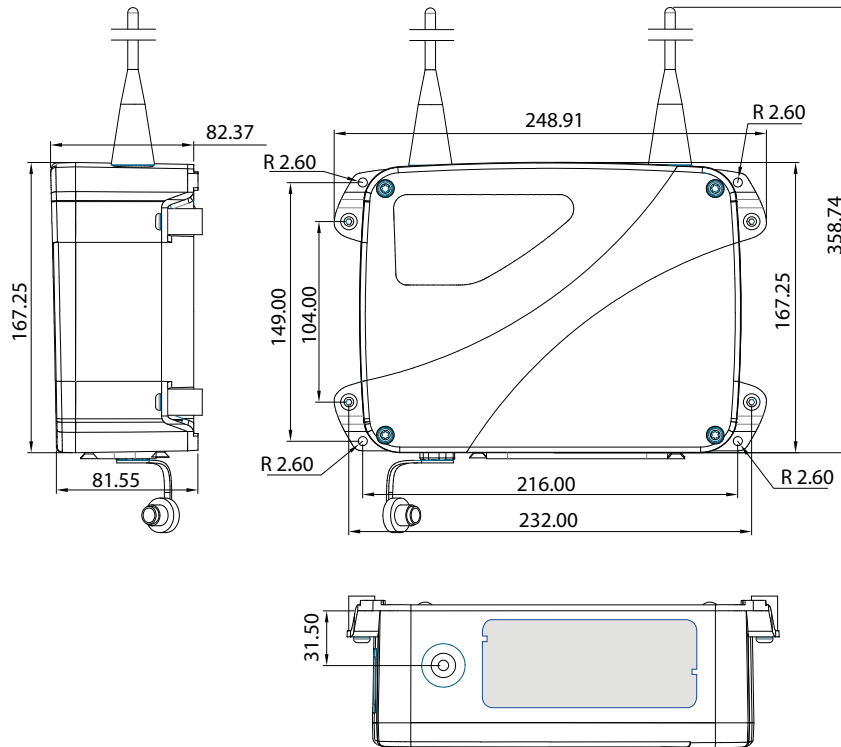

## Technical description

### MP20 hardware description

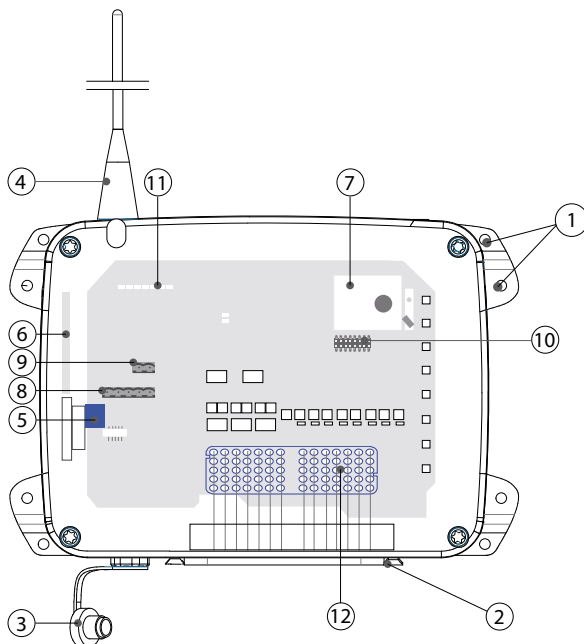

1. Fixing slots (fixed assembly or anti-vibration)
2. DEUTSCH connector
3. Tether connection
4. External antenna A60 (433), A70 (870) or 2.4GHz
5. External EEPROM
6. LCD connection
7. RF Module
8. CAN connection
9. CAN power supply
10. BUS termination CAN
11. Signaling internal LEDs
12. DEUTSCH connector pinout

### MP20A/MP20V detailed description

#### Technical data

Specification	MP20A	MP20V
Stop Function (400-900 MHz)	Cat. 3-PLd	
Stop Function (2.4GHz)	Cat. 3-PLe	
Ingress protection Rating	IP65/NEMA4	

## Technical description

### Technical data (continued)

Specification	MP20A	MP20V
Frequency band - ERP	433.050 to 434.040 MHz; ERP<1mW	
	434.040 to 434.790 MHz; ERP<10mW	
	869.700 to 870.000 MHz; ERP<5mW	
	902.000 to 928.000 MHz; ERP<1mW	
	2405MHz to 2475MHz 20dBm/100mW	
Range Line of sight (guaranteed)	100m	
AC power supply	N/A	
DC power supply	8-35 Vdc	
Receiver Current Consumption	200mA	
Antenna	External	
Removable EEPROM	External	
Signaling	External	
STOP Outputs (400-900MHZ)	1	
STOP Outputs (2.4GHz)	1	
Start Output	N/A	
Safety Relay	N/A	
ON/OFF Outputs	12 (2A per Output)	
Proportional Outputs	8 PWM (2.5A per Output)	8 Voltage (20mA per Output)
CAN Bus Protocols	CANopen	
ON/OFF Inputs	4	
Analog inputs	Optional	
Maximum Total Output Current	7.5A	
Working Temperature Range	-20°C to +70°C (-4° F to +158° F)	
Storage Temperature Range (24h)	-25°C to 75°C (-13°F to 167°F)	
Storage Temperature Range (long periods)	-25°C to 55°C (-13°F to 131°F)	
Relative Humidity	max. 95% without condensation	
Weight	1250 g	
Dimensions	245 x 160 x 80mm	
Tether Connector	Yes (M12 Connector)	
Associated Transmitters (400-900 MHz)	Ikargo2, T70/2, T70/2 HALL, IK2, IK3, IK4	
Associated Transmitters (2.4 GHz)	Ikore, IkoreB, Icompact, IK2, IK3, IK4	
<b>Additional Outputs</b>		
	8 ON/OFF or 2 (PWM or Voltage) or (20 ON/OFF or 5 Analog Inputs)	



## Installation

### MP20A receiver installation

The below information describes hazards to be aware of during installation and steps to locate the receiver.

#### Risk of shock

Completely shut down the machine when installing the receiver.

Check the power supply and shut off the main switch to disconnect the interface cable between the receiver and the machine's electrical box.

1. Find an easily accessible and clear location with a direct vision between the receiver's antenna and the transmitter's working area.

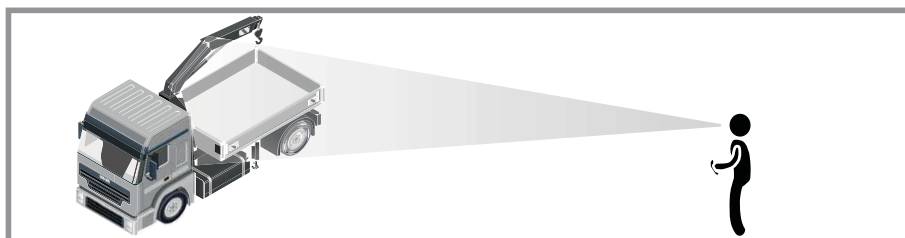

2. Optional: If it is difficult to achieve direct vision between the receiver's antenna and the transmitter's working area, it is recommended to use an extended antenna in a clear location (only for models that allow an antenna).

In areas of high vibration, the use of dampers is advised.



3. Proceed to connect the power supply. Use the connection block diagram provided with the system, where the correspondence between the transmitter maneuvers and the receiver's outputs are detailed.

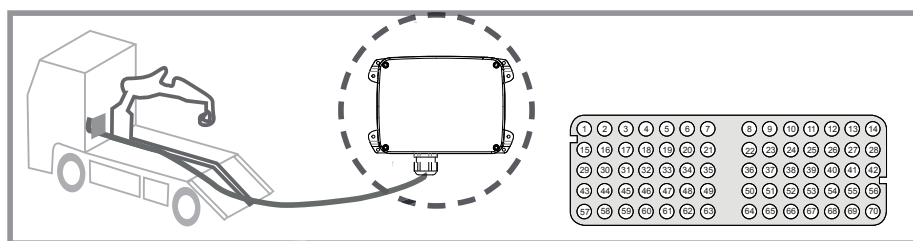

4. Check if the electrical installation and verify if there's an option to connect the neutral or the ground cable. In that case, don't forget to connect the ground cable.

The use of fireproof or flame retardant cables are recommended for the connection.

## Installation

### MP20 input and output configuration

The MP20 includes a 7.5A permeable internal fuse.

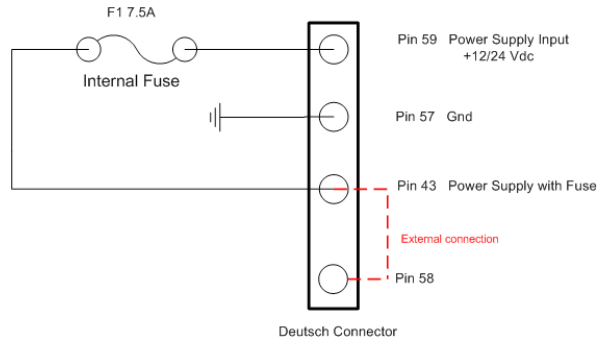

### MP20 digital outputs

The digital outputs K1-K4 have a common contact at pin 47 of the connector. This pin is connected to pin 46 (stop) for powering up this group of outputs. Maximum 2A per output. It is recommended to use K1 for by-pass valve.

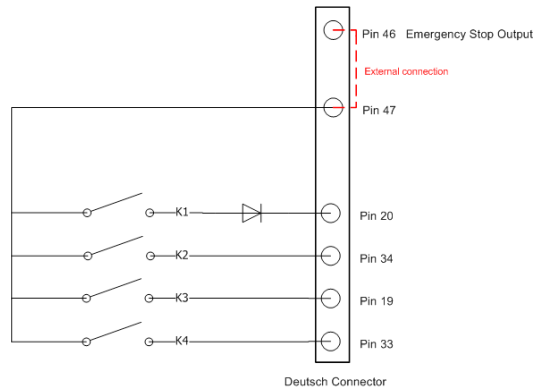

The digital output K5-K12 have a common contact at pin 48 of the connector. This pin is connected to pin 45 (stop) for powering up this group of outputs. Maximum 2A per output.

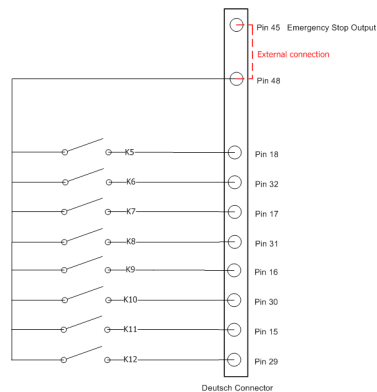

As an alternative, the K5-K12 output group can be connected directly to the external general power supply in order to provide a higher capacity of current.

## Installation

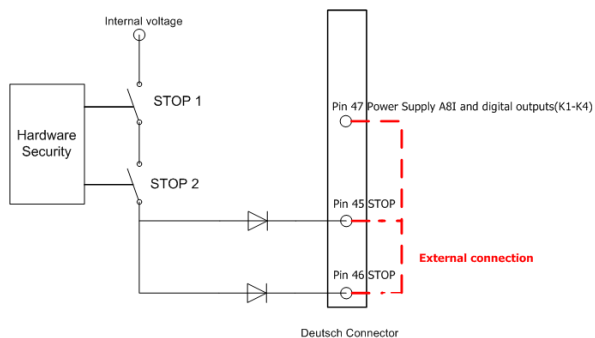
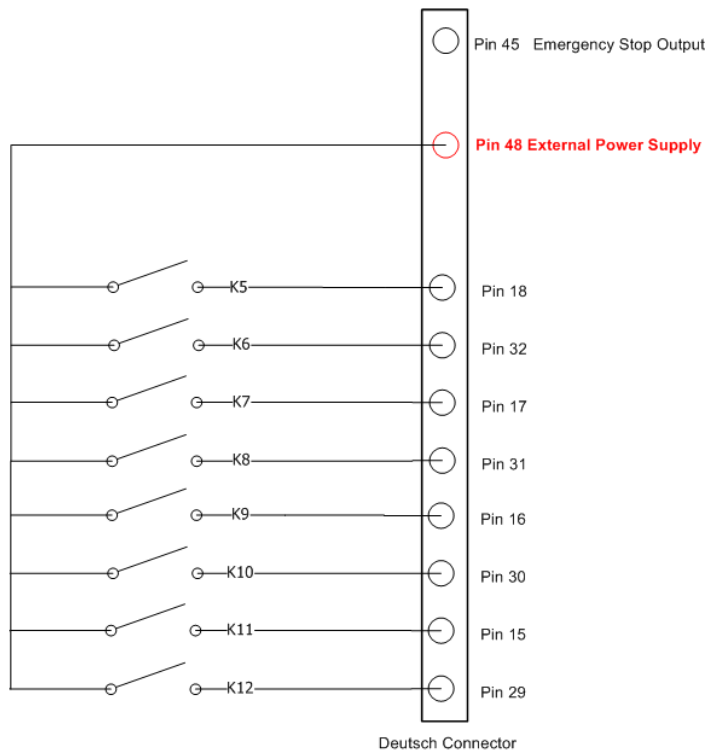

## Installation

### MP20 analog outputs

The analog outputs have a common contact at pin 47 of the connector. This pin is connected to pin 46 (stop) for powering up the 1-8 outputs. Maximum 2A per output.

nSA1-nSA8 have a common contact at pin 47 of the connector. Pin 47 connects with pin 46 (stop) in order to feed nSA1-nSA8 outputs. Maximum 2A per output.

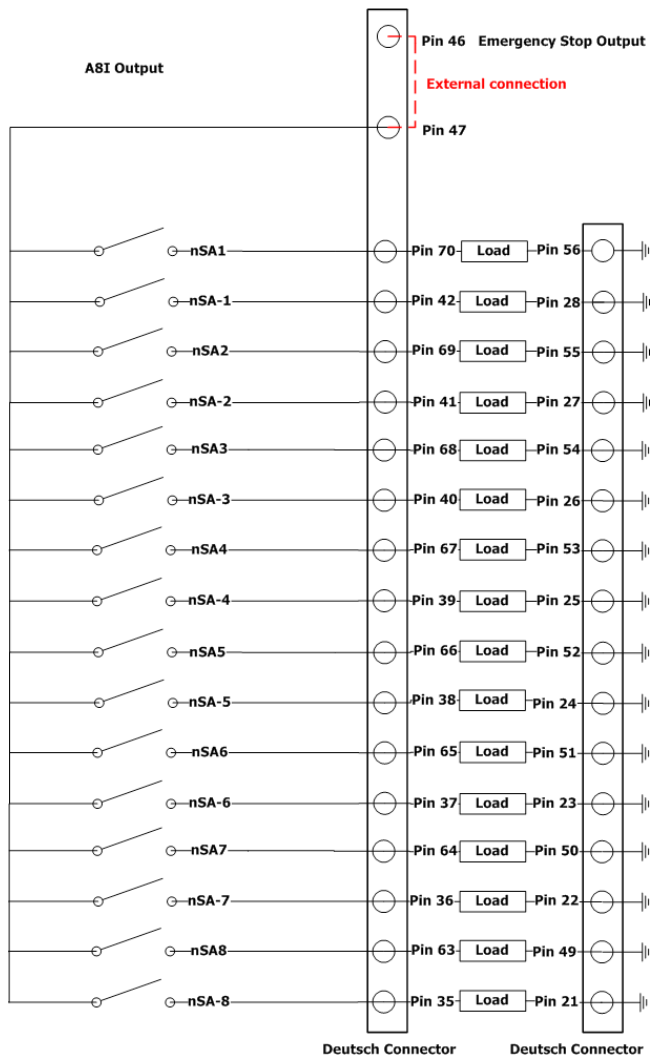

## Installation

### MP20 pinout

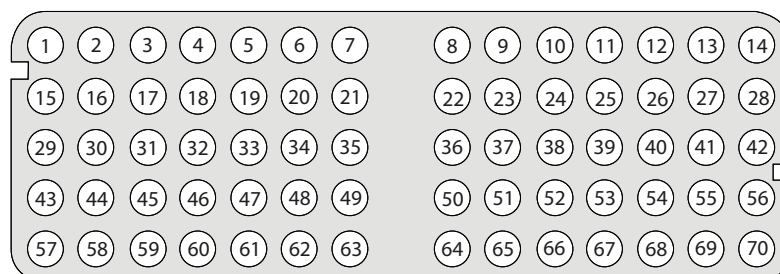

Pin	Description	Pin	Description
1	CAN-H	36	ISA-7
2	CAN-GND	37	ISA-6
3	CAN-L	38	ISA-5
4	-	39	ISA-4
5	-	40	ISA-3
6	-	41	ISA-2
7	IN-4	42	ISA-1
8	-	43	PSWF
9	-	44	HAND
10	-	45	STOP
11	-	46	STOP
12	-	47	PW-A81; K1-4
13	-	48	PW-A81; K5-K12
14	-	49	GND
15	K11	50	GND
16	K9	51	GND
17	K7	52	GND
18	K5	53	GND
19	K3	54	GND
20	K1	55	GND
21	GND	56	GND
22	GND	57	GND
23	GND	58	+RRC
24	GND	59	+12/24V
25	GND	60	IN-3
26	GND	61	IN-2
27	GND	62	IN-1
28	GND	63	ISA8
29	K12	64	ISA7
30	K10	65	ISA6
31	K8	66	ISA5
32	K6	67	ISA4
33	K4	68	ISA3
34	K2	69	ISA2
35	ISA-8	70	ISA1









## Troubleshooting

### 400 - 900MHz Receiver icon troubleshooting

The troubleshooting Display is located on the receiver side, accessible from the outside. Use the following table to identify faults and corrective action.

Please do check the following website for further information:

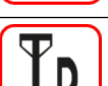
<https://troubleshooting.dps-rct.com/en/customer-service-center>

Icon	Description	Action
	Power failure	Check the receiver power supply
	Hardware error	Contact distributor; replace receiver
	CAN error	Contact your distributor
	Standby state due to active stop	Transmitter has been switched off by pressing the STOP button. Release stop button and turn transmitter on
	Standby state due to passive stop	Receiver has lost contact with Transmitter due to interference or Transmitter out of range. Press Start on Transmitter.
	Linked state	Correct link
	Correct ID (link quality as indicated by the bar)	In case of no signal, check if the transmitter is turned on
	Incorrect ID	In case of interference, change frequency channel
	RF signal detected	In case of interference, change frequency channel
	Mask error	Contact your distributor

### 2.4GHz Receiver Icon Troubleshooting

The troubleshooting Display is located on the receiver side, accessible from the outside. Use the following table to identify faults and corrective action.

In order to reach the internal signaling LEDs, the receiver must be accessible, connected, and the screws located on the receiver lid must be unscrewed using the proper screw driver. The LEDs on the receiver board are POWER, STATUS, DIAG1, DIAG2, ORDER, RELAY, CANERR and CANRUN in that order.

Please do check the following website for further information:

<https://troubleshooting.dps-rct.com/en/customer-service-center>

## Troubleshooting

Icon	Description	Action
	Power Fail	Check power supply
	Hardware Error	Replace Receiver
	CAN Error	Verify CAN connections and Status.
	Standby State due to Active STOP	Release STOP button and press START on the transmitter.
	Standby State due to Pasive Stop	Press Start on the Transmitter
	Linked Status	System working Correctly
	Mask Error	Check EEPROM and reprogram if necessary
	Receiver Initializing	Wait
	Radio communication error	Replace Receiver
	EEPROM module missing or corrupt	Check EEPROM and reprogram if necessary
	Hardware Error	Replace Receiver

**Troubleshooting**

(continued)

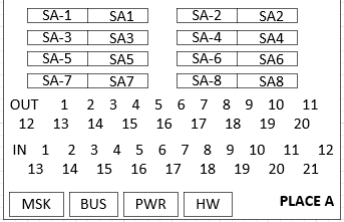
Icon	Description	Action
	CAN Bus configuration Error	Verify CAN Connections, addresses of Expansion boards and Bus terminations
	Standby and Operation Screen	Representation of Inputs and outputs being active at a time



### Products we offer:

- Cartridge valves
- DCV directional control valves
- Electric converters
- Electric machines
- Electric motors
- Gear motors
- Gear pumps
- Hydraulic integrated circuits (HICs)
- Hydrostatic motors
- Hydrostatic pumps
- Orbital motors
- PLUS+1® controllers
- PLUS+1® displays
- PLUS+1® joysticks and pedals
- PLUS+1® operator interfaces
- PLUS+1® sensors
- PLUS+1® software
- PLUS+1® software services, support and training
- Position controls and sensors
- PVG proportional valves
- Steering components and systems
- Telematics

**Danfoss Power Solutions** is a global manufacturer and supplier of high-quality hydraulic and electric components. We specialize in providing state-of-the-art technology and solutions that excel in the harsh operating conditions of the mobile off-highway market as well as the marine sector. Building on our extensive applications expertise, we work closely with you to ensure exceptional performance for a broad range of applications. We help you and other customers around the world speed up system development, reduce costs and bring vehicles and vessels to market faster.

Danfoss Power Solutions – your strongest partner in mobile hydraulics and mobile electrification.

### Go to [www.danfoss.com](http://www.danfoss.com) for further product information.

We offer you expert worldwide support for ensuring the best possible solutions for outstanding performance. And with an extensive network of Global Service Partners, we also provide you with comprehensive global service for all of our components.

Local address:

### Hydro-Gear

[www.hydro-gear.com](http://www.hydro-gear.com)

### Daikin-Sauer-Danfoss

[www.daikin-sauer-danfoss.com](http://www.daikin-sauer-danfoss.com)

**Danfoss  
Power Solutions (US) Company**  
2800 East 13th Street  
Ames, IA 50010, USA  
Phone: +1 515 239 6000

**Danfoss  
Power Solutions GmbH & Co. OHG**  
Krokamp 35  
D-24539 Neumünster, Germany  
Phone: +49 4321 871 0

**Danfoss  
Power Solutions ApS**  
Nordborgvej 81  
DK-6430 Nordborg, Denmark  
Phone: +45 7488 2222

**Danfoss  
Power Solutions Trading  
(Shanghai) Co., Ltd.**  
Building #22, No. 1000 Jin Hai Rd  
Jin Qiao, Pudong New District  
Shanghai, China 201206  
Phone: +86 21 2080 6201

Danfoss can accept no responsibility for possible errors in catalogues, brochures and other printed material. Danfoss reserves the right to alter its products without notice. This also applies to products already on order provided that such alterations can be made without subsequent changes being necessary in specifications already agreed. All trademarks in this material are property of the respective companies. Danfoss and the Danfoss logotype are trademarks of Danfoss A/S. All rights reserved.