

Data sheet

Solenoid valves

Type EVU for fluorinated refrigerants



EVU solenoid valves are designed to fit into compact refrigeration systems. Available in direct and servo operated versions, they can be applied in liquid, suction, and hot gas lines with fluorinated refrigerants.

EVU solenoid valves can be used in many different refrigeration systems and are specially designed for:

- commercial refrigeration systems
- refrigeration appliances
- liquid coolers
- ice cube machines
- mobile refrigeration systems
- heat pump systems
- air conditioning units

EVU valves are available in straightway or angleway design. All valves are semi hermetically sealed and are not serviceable. The standard coil is available with 3-core cable connection, DIN plug and 0.25 US spade.

EVU valve bodies and coils are ordered separately.

Features

- Compact construction small dimensions, low weight for both valve and coil.
- Semi-hermetic construction. Metallic sealing between armature tube and valve body. Bimetal connections to the brass housing Benefits:
 - high strength of joints and high vibration resistance
 - maximum external tightness within the whole temperature and pressure operation range
- Bimetal connections simple, fast soldering without the need of wet cloth or refrigeration pliers.
- Direct and servo operated mini piston compact solenoid valve.
- Universal application for
 - liquid, suction, and hot gas applications
 - reduced power consumption
- Simple and fast mounting of coil
 - clip - ON / OFF
- Small encapsulated coils with long life time under extreme conditions.
- Refrigerants: R744, R22 / R407C, R404A / R507, R410A, R134a, R407A, R23. For other refrigerants, please contact Danfoss.
- Large MOPD range – up to 36 bar.

Approvals

- UL Recognized Component (Canadian and US)
- Pressure Equipment Directive (PED) 2014/68/EU
- Low Voltage Directive (LVD) 2014/35/EU



Data sheet | Solenoid valve, type EVU for fluorinated refrigerants
Technical data
Refrigerants

R744, R22 / R407C, R404A / R507, R410A, R134a, R407A, R23.

For other refrigerants, please contact Danfoss.

Temperature of medium

-40 – 221 °F

Ambient temperature

-40 – 140 °F

MOPD operating range

0.029 psi up to 522 psi

Humidity

0 – 100% R.H. (0-97% R.H. non-condensation condition if IP level is below IPX5).

Type	Opening differential pressure with standard coil Δp [psi]		Temperature of medium [°F]	Max. working pressure [psi]	C_v – value ¹⁾ [gal / min]
	Min.	Max. (=MOPD) liquid ²⁾			
			8 W AC		
EVU 1	0.000	348 ³⁾	-40 – 221	1015	0.11
EVU 2	0.029	522	-40 – 221	1015	0.23
EVU 3	0.029	522	-40 – 221	1015	0.35
EVU 4	0.029	522	-40 – 221	1015	0.58
EVU 5	0.029	522	-40 – 221	1015	0.76
EVU 6	0.029	522	-40 – 221	1015	0.93
EVU 8	0.029	522	-40 – 221	1015	1.15

¹⁾ C_v value is the water flow in [gal / min] at a pressure drop across valve $\Delta p = 1$ psi, $\rho = 10$ lbs / gal

²⁾ MOPD for media in gas form is approximately 14 psi greater

³⁾ For coil 208 – 240 V, 60 Hz, MOPD is 250 psi

MOPD (Max. Opening Pressure Differential) is measured with highest media and ambient temperature and 15% below nominal voltage

Type	Rated capacity ¹⁾ / [TR]											
	Liquid				Suction vapour				Hot gas			
	R22 / R407C	R134a	R404A / R507	R410A	R22 / R407C	R134a	R404A / R507	R410A	R22 / R407C	R134a	R404A / R507	R410A
EVU 1	0.64	0.48	0.44	0.64	0.55	0.04	0.05	0.06	0.12	0.10	0.10	0.18
EVU 2	1.27	0.96	0.87	1.27	0.11	0.08	0.09	0.13	0.24	0.19	0.19	0.36
EVU 3	1.90	1.45	1.31	1.90	0.16	0.12	0.14	0.19	0.35	0.29	0.28	0.53
EVU 4	3.19	2.41	2.18	3.17	0.26	0.20	0.23	0.32	0.59	0.48	0.47	0.89
EVU 5	4.12	3.13	2.83	4.12	0.34	0.26	0.30	0.42	0.76	0.62	0.61	1.16
EVU 6	5.07	3.86	3.49	5.07	0.42	0.32	0.37	0.51	0.94	0.77	0.76	1.42
EVU 8	6.34	4.83	4.36	6.34	0.53	0.40	0.46	0.64	1.18	0.96	0.95	1.78

¹⁾ Rated liquid and suction vapor capacity are based on:

- evaporating temperature $t_e = 40$ °F
- liquid temperature ahead of valve $t_l = 100$ °F
- pressure drop Δp across valve
 - with liquid $\Delta p = 2$ psi for R134a, $\Delta p = 3$ psi for R22 / R407C, R404A and R507
 - with suction vapor $\Delta p = 1$ psi

Rated hot gas capacity is based on:

- condensing temperature $t_c = 100$ °F
- hot gas temperature $t_h = 140$ °F
- pressure drop across valve $\Delta p = 2$ psi

Metric conversions:

- 1 psi = 0.07 bar
- $^5/9 (t_1 \text{ °F} - 32) = 12 \text{ °C}$
- 1 TR = 3.5 Kw
- 1 in = 25.4 mm
- 1 ft = 0.3 m
- 1 lb = 0.454 kg
- 1 oz = 28.35 gram
- US gal / min = 0.86 m³ / h

Data sheet | Solenoid valve, type EVU for fluorinated refrigerants

Ordering valve

EVU 1 – EVU 6

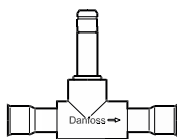

EVU 8

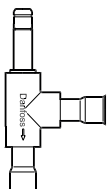

Single pack

1 product in a box with installation guide

Multi pack

box with x pieces single pack (can be split)

Industrial pack

x pieces in one box (cannot be split)

Normally closed NC

Type	Connection		Industrial pack		Multiple pack
	[in.]	[mm]	Code no.	Pcs.	Code no.
EVU 1	1/4	–	032F7005	40	032F9524
	–	6	032F7004	40	–
EVU 2	–	6	032F5053	40	032F9529
EVU 3	1/4	–	032F5024	40	032F9525
	–	6	032F5025	40	032F9530
	3/8	–	032F5026	40	032F5111
EVU 4	–	10	032F5027	40	–
	–	10	032F5037	40	032F9531
EVU 5	3/8	–	032F7000	40	032F9526
	–	10	032F7001	40	032F9532
	–	12	032F7003	40	–
EVU 6	3/8	–	032F5046	40	032F9527
	–	10	032F5047	40	–
	1/2	–	032F5049	40	032F9528
	–	12	032F5048	40	032F9533
EVU 8	–	12	032F8009	40	–

The valve code numbers on above are with coil sealing O-ring. This should be removed For US-coils with the external Frame.

0.25 in. US spade connections

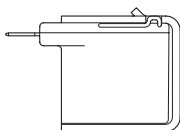

Alternating current AC with US spade IP00

Type	Ambient Temp. [°C]	Supply voltage [V]	Voltage variation	Frequency [Hz]	Power consumption		Industrial pack		Multi pack
					[W]	[VA]	Code no.	Pcs.	Code no.
AY240C	-40 – 50	208 – 240	-15% – 10%	50	8.0	16	042N8230	40	042N4230
		208 – 240	-15% – 10%	60	8.0	16			
AY120C	-40 – 50	110 – 120	-15% – 10%	50	8.0	16	042N8233	40	042N4233
		110 – 120	-15% – 10%	60	8.0	16			
AY024C	-40 – 50	24	-15% – 10%	50	8.0	16	042N8236	40	–
		24	-15% – 10%	60	8.0	16			

0.25 in. US spade connection

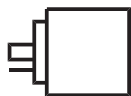

Single pack

1 product in a box with installation guide

Multi pack

box with x pieces single pack (can be split)

Industrial pack

x pieces in one box (cannot be split)

Alternating current AC with US DIN spade IP00

Type	Ambient Temp. [°C]	Supply voltage [V]	Voltage variation	Frequency [Hz]	Power consumption		Industrial pack		Multi pack
					[W]	[VA]	Code no.	Pcs.	Code no.
AZ240CS	-40 – 50	230	-15% – 10%	50	8.0	16	042N8201	40	042N4201
		208 – 240	-15% – 10%	60	7.0	14			
AZ120CS	-40 – 50	115	-15% – 10%	50	8.5	16	042N8202	40	042N4202
		110 – 120	-15% – 10%	60	7.0	14			
AZ024CS	-40 – 50	24	-15% – 10%	50	9.5	18	042N8203	40	042N4203
		24	-15% – 10%	60	7.0	14			

Accessories

Part	Description	Code no.			
		Multi pack	Pcs.	Industrial pack	Pcs.
	DIN plug (EN175301-803 type A)	042N0156		–	
	O-ring for sealing the coil. Industrial pack (50 pcs.) NB: Valve body supplied with O-ring	032F6115		–	
	Bracket for fixing of valve.	–		032F8036	40

Data sheet | Solenoid valve, type EVU for fluorinated refrigerants
**Capacity
Liquid capacity**

Type	Liquid capacity Q _o [TR] at pressure drop across valve Δp [bar]						
	1	2	3	4	5	6	7
R22 / R407C							
EVU 1	0.34	0.52	0.64	0.73	0.82	0.85	0.97
EVU 2	0.68	1.03	1.27	1.46	1.63	1.79	1.93
EVU 3	1.02	1.55	1.90	2.19	2.45	2.69	2.90
EVU 4	1.69	2.59	3.17	3.66	4.09	4.48	4.84
EVU 5	2.20	3.36	4.12	4.75	5.31	5.83	6.29
EVU 6	2.71	4.14	5.07	5.85	6.54	7.17	7.74
EVU 8	3.39	5.18	6.34	7.31	8.18	8.96	9.68
R134A							
EVU 1	0.34	0.48	0.59	0.68	0.76	0.84	0.90
EVU 2	0.68	0.96	1.18	1.36	1.52	1.67	1.80
EVU 3	1.02	1.45	1.77	2.05	2.29	2.51	2.71
EVU 4	1.71	2.41	2.59	3.41	3.81	4.18	4.84
EVU 5	2.22	3.13	3.84	4.43	4.96	5.43	5.86
EVU 6	2.73	3.86	4.73	5.45	6.10	6.68	7.22
EVU 8	3.41	4.83	5.91	6.81	7.63	8.35	9.03
R404A/507							
EVU 1	0.25	0.36	0.44	0.51	0.57	0.62	0.67
EVU 2	0.50	0.71	0.87	1.01	1.13	1.23	1.33
EVU 3	0.76	1.07	1.31	1.51	1.69	1.85	2.00
EVU 4	1.26	1.78	2.18	2.52	2.81	3.09	3.33
EVU 5	1.64	2.31	2.83	3.27	3.66	4.01	4.33
EVU 6	2.02	2.85	3.49	4.03	4.50	4.94	5.33
EVU 8	2.53	3.56	4.36	5.04	5.63	6.18	6.66
R410a							
EVU 1	0.34	0.52	0.64	0.73	0.82	0.90	0.97
EVU 2	0.68	1.03	1.27	1.46	1.63	1.79	1.93
EVU 3	1.02	1.55	1.90	2.19	2.44	2.69	2.90
EVU 4	1.69	2.59	3.17	3.66	4.07	4.48	4.84
EVU 5	2.20	3.36	4.12	4.75	5.29	5.83	6.29
EVU 6	2.71	4.14	5.07	5.85	6.51	7.17	7.74
EVU 8	3.39	5.18	6.34	7.31	8.14	8.96	9.68

Metric conversions

- 1 psi = 0.07 bar
- $\frac{5}{9} (t_1 \text{ °F} - 32) = t_2 \text{ °C}$
- 1 TR = 3.5 kW

Capacities are based on:
 - liquid temperature $t_l = 100 \text{ °F}$,
 - evaporating temperature $t_e = 40 \text{ °F}$,
 - superheat temperature $(t_e + 10 \text{ °F}) = 50 \text{ °F}$.

Correction factors for liquid temperature t_l

t_l [°F]	80	90	100	110	120
Factor	1.10	1.05	1.00	0.95	0.90

When liquid temperature t_l ahead of the expansion valve is other than 100 °F, adjust the table capacities by multiplying them by the appropriate correction factor found in the following table.

Data sheet | Solenoid valve, type EVU for fluorinated refrigerants
**Capacity
Suction vapour capacity**

Type	Pressure drop Δp [psi]	Suction vapour capacity Q_e [TR] at evaporating temperature t_e [°F]							
		-40	-20	0	10	20	30	40	50
R22 / R407C									
EVU 1	1.00	0.02	0.03	0.04	0.04	0.05	0.05	0.06	0.08
	2.00	0.03	0.04	0.05	0.06	0.06	0.07	0.08	0.08
	3.00	0.03	0.05	0.06	0.07	0.07	0.08	0.09	0.10
EVU 2	1.00	0.04	0.05	0.07	0.08	0.09	0.09	0.11	0.12
	2.00	0.05	0.07	0.09	0.11	0.12	0.13	0.15	0.16
	3.00	0.06	0.09	0.11	0.13	0.14	0.16	0.18	0.20
EVU 3	1.00	0.06	0.08	0.10	0.12	0.13	0.14	0.16	0.17
	2.00	0.08	0.11	0.14	0.16	0.18	0.20	0.22	0.25
	3.00	0.09	0.13	0.17	0.19	0.22	0.25	0.27	0.30
EVU 4	1.00	0.10	0.14	0.17	0.19	0.21	0.24	0.26	0.29
	2.00	0.13	0.18	0.23	0.27	0.30	0.34	0.37	0.41
	3.00	0.16	0.22	0.28	0.32	0.36	0.41	0.45	0.50
EVU 5	1.00	0.13	0.18	0.22	0.25	0.28	0.31	0.34	0.37
	2.00	0.17	0.24	0.30	0.35	0.39	0.44	0.48	0.53
	3.00	0.20	0.28	0.37	0.41	0.47	0.54	0.59	0.65
EVU 6	1.00	0.16	0.22	0.27	0.31	0.34	0.38	0.42	0.46
	2.00	0.21	0.29	0.37	0.44	0.48	0.54	0.59	0.65
	3.00	0.25	0.35	0.45	0.51	0.57	0.66	0.73	0.80
EVU 8	1.00	0.20	0.28	0.34	0.39	0.43	0.48	0.53	0.58
	2.00	0.26	0.36	0.46	0.55	0.60	0.68	0.74	0.81
	3.00	0.31	0.44	0.56	0.64	0.71	0.83	0.91	1.00

Metric conversions

- 1 psi = 0.07 bar
- $\frac{5}{9} (t_1 \text{ °F} - 32) = t_2 \text{ °C}$
- 1 TR = 3.5 kW

The table values refer to evaporator capacity and are given as a function of:
 - evaporating temperature t_e ,
 - pressure drop Δp across the valve.

Capacities are based on:
 - liquid temperature $t_l = 100 \text{ °F}$ ahead of the expansion valve,
 - superheat $t_s = 7 \text{ °F}$.
 For each additional 10 °F of superheat, the table capacities must be reduced by 2%.

Correction factors for liquid temperature t_l

t_l [°F]	80	90	100	110	120
Factor	1.10	1.05	1.00	0.95	0.90

When liquid temperature t_l ahead of the expansion valve is other than 100 °F , adjust the table capacities by multiplying them by the appropriate correction factor found in the following table.

Data sheet | Solenoid valve, type EVU for fluorinated refrigerants
**Capacity
Suction vapour capacity
(continued)**

Type	Pressure drop Δp [psi]	Suction vapour capacity Q_e [TR] at evaporating temperature t_e [°F]							
		-40	-20	0	10	20	30	40	50
R134a									
EVU 1	1.00	0.01	0.02	0.03	0.03	0.03	0.04	0.04	0.05
	2.00	0.02	0.03	0.04	0.04	0.05	0.05	0.06	0.07
	3.00	0.02	0.03	0.04	0.05	0.05	0.06	0.07	0.08
EVU 2	1.00	0.02	0.03	0.05	0.06	0.06	0.07	0.08	0.09
	2.00	0.03	0.05	0.07	0.08	0.09	0.10	0.11	0.13
	3.00	0.03	0.05	0.08	0.09	0.10	0.12	0.13	0.16
EVU 3	1.00	0.04	0.05	0.07	0.08	0.10	0.11	0.12	0.14
	2.00	0.05	0.07	0.10	0.11	0.13	0.15	0.17	0.19
	3.00	0.05	0.08	0.12	0.14	0.16	0.18	0.20	0.23
EVU 4	1.00	0.06	0.09	0.12	0.14	0.16	0.18	0.20	0.23
	2.00	0.08	0.12	0.16	0.19	0.22	0.25	0.29	0.32
	3.00	0.09	0.13	0.19	0.23	0.26	0.30	0.34	0.39
EVU 5	1.00	0.08	0.11	0.16	0.18	0.21	0.23	0.26	0.29
	2.00	0.10	0.15	0.21	0.24	0.28	0.33	0.37	0.42
	3.00	0.11	0.17	0.25	0.29	0.34	0.39	0.44	0.51
EVU 6	1.00	0.10	0.14	0.20	0.22	0.25	0.29	0.32	0.36
	2.00	0.13	0.19	0.26	0.30	0.35	0.41	0.46	0.51
	3.00	0.14	0.21	0.31	0.36	0.41	0.48	0.54	0.63
EVU 8	1.00	0.13	0.18	0.25	0.28	0.31	0.36	0.40	0.45
	2.00	0.16	0.24	0.33	0.38	0.44	0.51	0.58	0.64
	3.00	0.18	0.26	0.39	0.45	0.51	0.60	0.68	0.79

Metric conversions

- 1 psi = 0.07 bar
- $\frac{5}{9}(t_1\text{ °F} - 32) = t_2\text{ °C}$
- 1 TR = 3.5 kW

The table values refer to evaporator capacity and are given as a function of:
 - evaporating temperature t_e ,
 - pressure drop Δp across the valve.

Capacities are based on:
 - liquid temperature $t_l = 100\text{ °F}$ ahead of the expansion valve,
 - superheat $t_s = 7\text{ °F}$.
 For each additional 10 °F of superheat, the table capacities must be reduced by 2%.

Correction factors for liquid temperature t_l

t_l [°F]	80	90	100	110	120
Factor	1.10	1.05	1.00	0.95	0.90

When liquid temperature t_l ahead of the expansion valve is other than 100 °F , adjust the table capacities by multiplying them by the appropriate correction factor found in the following table.

Data sheet | Solenoid valve, type EVU for fluorinated refrigerants
**Capacity
Suction vapour capacity
(continued)**

Type	Pressure drop Δp [psi]	Suction vapour capacity Q_e [TR] at evaporating temperature t_e [°F]							
		-40	-20	0	10	20	30	40	50
R404A/507									
EVU 1	1.00	0.02	0.02	0.03	0.04	0.04	0.04	0.05	0.05
	2.00	0.02	0.03	0.04	0.05	0.05	0.06	0.07	0.08
	3.00	0.03	0.04	0.05	0.06	0.07	0.07	0.08	0.09
EVU 2	1.00	0.03	0.04	0.06	0.07	0.07	0.08	0.09	0.10
	2.00	0.04	0.06	0.08	0.09	0.10	0.12	0.13	0.15
	3.00	0.05	0.07	0.10	0.11	0.13	0.14	0.16	0.18
EVU 3	1.00	0.05	0.07	0.09	0.10	0.11	0.12	0.14	0.16
	2.00	0.06	0.09	0.12	0.14	0.16	0.18	0.20	0.22
	3.00	0.08	0.11	0.14	0.16	0.19	0.22	0.24	0.27
EVU 4	1.00	0.08	0.11	0.14	0.17	0.18	0.21	0.23	0.26
	2.00	0.11	0.15	0.20	0.23	0.26	0.29	0.33	0.37
	3.00	0.13	0.18	0.24	0.27	0.32	0.36	0.40	0.45
EVU 5	1.00	0.10	0.14	0.19	0.22	0.24	0.27	0.30	0.34
	2.00	0.14	0.19	0.27	0.30	0.34	0.38	0.43	0.48
	3.00	0.16	0.23	0.31	0.36	0.41	0.47	0.52	0.58
EVU 6	1.00	0.13	0.17	0.23	0.27	0.29	0.33	0.37	0.41
	2.00	0.17	0.24	0.33	0.37	0.42	0.47	0.52	0.59
	3.00	0.20	0.28	0.38	0.44	0.51	0.58	0.64	0.72
EVU 8	1.00	0.16	0.21	0.29	0.34	0.36	0.41	0.46	0.51
	2.00	0.21	0.30	0.41	0.46	0.53	0.59	0.65	0.74
	3.00	0.25	0.35	0.48	0.55	0.64	0.73	0.80	0.90

Metric conversions

- 1 psi = 0.07 bar
- $\frac{5}{9}(t_1 \text{ °F} - 32) = t_2 \text{ °C}$
- 1 TR = 3.5 kW

The table values refer to evaporator capacity and are given as a function of:
 - evaporating temperature t_e ,
 - pressure drop Δp across the valve.

Capacities are based on:
 - liquid temperature $t_l = 100 \text{ °F}$ ahead of the expansion valve,
 - superheat $t_s = 7 \text{ °F}$.
 For each additional 10 °F of superheat, the table capacities must be reduced by 2%.

Correction factors for liquid temperature t_l

t_l [°F]	80	90	100	110	120
Factor	1.10	1.05	1.00	0.95	0.90

When liquid temperature t_l ahead of the expansion valve is other than 100 °F , adjust the table capacities by multiplying them by the appropriate correction factor found in the following table.

Data sheet | Solenoid valve, type EVU for fluorinated refrigerants
**Capacity
Suction vapour capacity
(continued)**

Type	Pressure drop Δp [psi]	Suction vapour capacity Q_e [TR] at evaporating temperature t_e [°F]							
		-40	-20	0	10	20	30	40	50
R410A									
EVU 1	1.00	0,03	0,04	0,05	0,05	0,06	0,06	0,07	0,08
	2.00	0,04	0,05	0,06	0,07	0,08	0,09	0,10	0,11
	3.00	0,05	0,06	0,08	0,08	0,10	0,11	0,12	0,13
EVU 2	1.00	0,05	0,07	0,09	0,10	0,11	0,12	0,13	0,15
	2.00	0,07	0,10	0,12	0,14	0,16	0,17	0,19	0,21
	3.00	0,09	0,12	0,15	0,16	0,19	0,21	0,23	0,25
EVU 3	1.00	0,08	0,11	0,13	0,15	0,17	0,18	0,19	0,22
	2.00	0,11	0,15	0,18	0,21	0,23	0,26	0,28	0,31
	3.00	0,13	0,17	0,22	0,25	0,28	0,31	0,34	0,38
EVU 4	1.00	0,14	0,18	0,22	0,25	0,28	0,30	0,32	0,36
	2.00	0,18	0,24	0,31	0,35	0,39	0,43	0,47	0,52
	3.00	0,22	0,29	0,37	0,41	0,47	0,52	0,56	0,63
EVU 5	1.00	0,18	0,23	0,29	0,32	0,36	0,39	0,42	0,47
	2.00	0,24	0,31	0,40	0,46	0,51	0,55	0,60	0,67
	3.00	0,29	0,38	0,48	0,54	0,60	0,68	0,73	0,82
EVU 6	1.00	0,22	0,29	0,36	0,40	0,45	0,48	0,51	0,58
	2.00	0,30	0,39	0,49	0,56	0,62	0,68	0,74	0,82
	3.00	0,35	0,46	0,59	0,66	0,74	0,84	0,90	1,01
EVU 8	1.00	0,28	0,36	0,45	0,50	0,56	0,60	0,64	0,73
	2.00	0,38	0,49	0,61	0,70	0,78	0,85	0,93	1,03
	3.00	0,44	0,58	0,74	0,83	0,93	1,05	1,13	1,26

Metric conversions

- 1 psi = 0.07 bar
- $\frac{5}{9}(t_1 \text{ °F} - 32) = t_2 \text{ °C}$
- 1 TR = 3.5 kW

The table values refer to evaporator capacity and are given as a function of:
 - evaporating temperature t_e ,
 - pressure drop Δp across the valve.

Capacities are based on:
 - liquid temperature $t_l = 100 \text{ °F}$ ahead of the expansion valve,
 - superheat $t_s = 7 \text{ °F}$.
 For each additional 10 °F of superheat, the table capacities must be reduced by 2%.

Correction factors for liquid temperature t_l

t_l [°F]	80	90	100	110	120
Factor	1.10	1.05	1.00	0.95	0.90

When liquid temperature t_l ahead of the expansion valve is other than 100 °F, adjust the table capacities by multiplying them by the appropriate correction factor found in the following table.

Data sheet | Solenoid valve, type EVU for fluorinated refrigerants
**Capacity
Hot gas capacity**

Type	Pressure drop across valve Δp [psi]	Hot gas capacity Q_h [TR]											
		Evaporating temp. $t_e = 40^\circ\text{F}$, hot gas temp. $t_h = t_e + 40^\circ\text{F}$, subcooling $\Delta t_s = 10^\circ\text{F}$											
		Condensing temp. t_c [$^\circ\text{F}$]											
		R22 / R407C			R134a			R404A/R 507			R410A		
		70	100	140	70	100	140	70	100	140	70	100	140
EVU 1	2	0,11	0,12	0,13	0,09	0,10	0,10	0,09	0,10	0,09	0,17	0,18	0,17
	5	0,17	0,19	0,20	0,14	0,16	0,16	0,15	0,15	0,15	0,27	0,29	0,27
	10	0,24	0,27	0,29	0,19	0,22	0,23	0,20	0,22	0,21	0,36	0,38	0,38
	15	0,29	0,32	0,36	0,24	0,26	0,29	0,25	0,26	0,26	0,45	0,48	0,48
	20	0,33	0,37	0,40	0,28	0,31	0,32	0,28	0,30	0,29	0,52	0,55	0,54
	25	0,37	0,41	0,44	0,31	0,34	0,36	0,32	0,33	0,32	0,58	0,62	0,60
EVU 2	2	0,21	0,24	0,25	0,17	0,19	0,20	0,18	0,19	0,18	0,34	0,36	0,34
	5	0,34	0,38	0,40	0,28	0,31	0,32	0,29	0,30	0,29	0,54	0,57	0,54
	10	0,47	0,54	0,57	0,38	0,43	0,46	0,40	0,43	0,42	0,72	0,76	0,75
	15	0,57	0,63	0,71	0,47	0,52	0,57	0,49	0,51	0,51	0,90	0,96	0,96
	20	0,66	0,73	0,79	0,55	0,61	0,64	0,56	0,59	0,57	1,03	1,10	1,07
	25	0,73	0,82	0,88	0,61	0,68	0,72	0,63	0,66	0,64	1,16	1,23	1,19
EVU 3	2	0,32	0,35	0,38	0,26	0,29	0,30	0,27	0,28	0,27	0,50	0,53	0,51
	5	0,51	0,56	0,60	0,42	0,46	0,48	0,43	0,45	0,44	0,81	0,85	0,81
	10	0,71	0,81	0,86	0,58	0,64	0,69	0,60	0,65	0,62	1,08	1,14	1,12
	15	0,86	0,95	1,06	0,71	0,79	0,85	0,73	0,77	0,77	1,36	1,44	1,44
	20	0,99	1,10	1,19	0,82	0,91	0,96	0,84	0,88	0,86	1,55	1,64	1,61
	25	1,10	1,22	1,32	0,92	1,02	1,08	0,95	0,99	0,96	1,74	1,85	1,79
EVU 4	2	0,53	0,59	0,63	0,44	0,48	0,50	0,45	0,47	0,46	0,84	0,89	0,85
	5	0,85	0,94	1,00	0,70	0,77	0,80	0,72	0,75	0,73	1,35	1,42	1,36
	10	1,18	1,35	1,43	0,96	1,07	1,15	1,00	1,08	1,04	1,80	1,91	1,87
	15	1,43	1,59	1,77	1,18	1,31	1,42	1,22	1,28	1,28	2,26	2,40	2,39
	20	1,64	1,83	1,98	1,37	1,52	1,60	1,41	1,47	1,43	2,58	2,74	2,69
	25	1,83	2,04	2,21	1,53	1,70	1,80	1,58	1,65	1,60	2,89	3,08	2,98

Metric conversions

- 1 psi = 0.07 bar
- $\frac{5}{9}(t_1^\circ\text{F} - 32) = t_2^\circ\text{C}$
- 1 TR = 3.5 kW

The table values refer to hot gas capacity and are given as a function of:

- condensing temperature t_c ,
- pressure drop Δp across the valve.

Capacities are based on:

- hot gas temperature superheated 40°F above condensing temperature ($t_h = t_c + 40^\circ\text{F}$).
- For each additional 10°F of superheat above 40°F , the table capacities must be reduced by 1%.

Correction factors for t_h and t_c

t_c [$^\circ\text{F}$]	-40	-20	0	20	40	50
Factor	1.18	1.14	1.09	1.04	1	0.97

When the valve is used in a hot gas defrost circuit, evaporator temperature affects the capacity. When the evaporator temperature differs from 40°F , adjust the table capacities by multiplying them by the appropriate correction factor found in the following table.

Data sheet | Solenoid valve, type EVU for fluorinated refrigerants

**Capacity
Hot gas capacity**

Type	Pressure drop across valve Δp [psi]	Hot gas capacity Q_h [TR]											
		Evaporating temp. $t_e = 40^\circ\text{F}$, hot gas temp. $t_h = t_e + 40^\circ\text{F}$, subcooling $\Delta t_s = 10^\circ\text{F}$											
		Condensing temp. t_c [$^\circ\text{F}$]											
		R22 / R407C			R134a			R404A/R 507			R410A		
	70	100	140	70	100	140	70	100	140	70	100	140	
EVU 5	2	0.69	0.76	0.82	0.57	0.62	0.65	0.59	0.61	0.59	1.09	1.16	1.11
	5	1.11	1.22	1.31	0.91	1.00	1.04	0.94	0.98	0.94	1.75	1.84	1.76
	10	1.53	1.75	1.86	1.25	1.39	1.49	1.29	1.41	1.35	2.35	2.48	2.44
	15	1.86	2.06	2.30	1.53	1.70	1.85	1.59	1.66	1.67	2.94	3.12	3.11
	20	2.14	2.38	2.57	1.78	1.97	2.08	1.83	1.91	1.86	3.35	3.56	3.49
	25	2.38	2.65	2.87	1.99	2.21	2.34	2.06	2.15	2.08	3.76	4.01	3.88
EVU 6	2	0.85	0.94	1.01	0.70	0.77	0.80	0.72	0.76	0.73	1.35	1.42	1.37
	5	1.36	1.50	1.61	1.12	1.23	1.28	1.16	1.21	1.16	2.16	2.27	2.17
	10	1.88	2.15	2.29	1.54	1.71	1.84	1.59	1.73	1.66	2.89	3.05	3.00
	15	2.29	2.54	2.84	1.89	2.10	2.28	1.96	2.04	2.05	3.62	3.83	3.83
	20	2.63	2.93	3.16	2.19	2.43	2.56	2.25	2.35	2.29	4.12	4.38	4.30
	25	2.93	3.27	3.53	2.45	2.72	2.88	2.53	2.65	2.56	4.63	4.93	4.77
EVU 8	2	1.06	1.18	1.26	0.88	0.96	1.00	0.90	0.95	0.91	1.69	1.78	1.71
	5	1.70	1.88	2.01	1.40	1.54	1.60	1.45	1.51	1.45	2.70	2.84	2.71
	10	2.35	2.69	2.86	1.93	2.14	2.30	1.99	2.16	2.08	3.61	3.81	3.75
	15	2.86	3.18	3.55	2.36	2.63	2.85	2.45	2.55	2.56	4.53	4.79	4.79
	20	3.29	3.66	3.95	2.74	3.04	3.20	2.81	2.94	2.86	5.15	5.48	5.38
	25	3.66	4.09	4.41	3.06	3.40	3.60	3.16	3.68	3.20	5.79	6.16	5.96

Metric conversions

- 1 psi = 0.07 bar
- $\frac{5}{9}(t_1^\circ\text{F} - 32) = t_2^\circ\text{C}$
- 1 TR = 3.5 kW

The table values refer to hot gas capacity and are given as a function of:

- condensing temperature t_c ,
- pressure drop Δp across the valve.

Capacities are based on:

- hot gas temperature superheated 40°F above condensing temperature ($t_h = t_c + 40^\circ\text{F}$).
- For each additional 10°F of superheat above 40°F , the table capacities must be reduced by 1%.

Correction factors for t_h and t_c

t_i [$^\circ\text{F}$]	-40	-20	0	20	40	50
Factor	1.18	1.14	1.09	1.04	1	0.97

When the valve is used in a hot gas defrost circuit, evaporator temperature affects the capacity. When the evaporator temperature differs from 40°F , adjust the table capacities by multiplying them by the appropriate correction factor found in the following table.

Design / Function

1. Solder connection
5. Solder connection
2. Solder ring
4. Solder ring
3. Valve housing
6. Union nut
7. Armature tube
8. Return spring
9. Armature
10. Support ring
11. Pilot plate (servo)
12. Seat plate (servo)
13. Piston (servo)

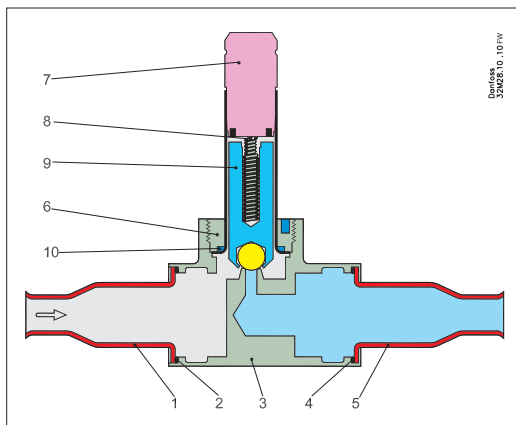
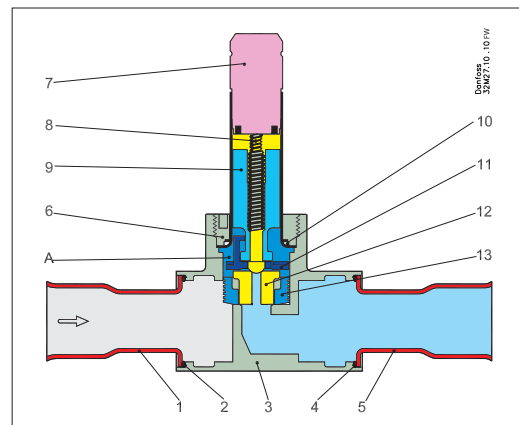
Direct operated

Servo operated

Direct operated

EVU 1 is direct operated. The valve opens directly for full flow when the armature (9) moves up into the magnetic field of the coil.

This means that the valve can operate at 0 bar differential pressure. Thus, inlet pressure and spring force act to close the valve when the coil is currentless.

Servo operated

EVU 2 - 8 are servo operated piston solenoid valves. The servo piston principle results in a fast operating and compact valve that is able to open against a high differential pressure. The valve closes rather soft, because the pilot system does not fully close before the main orifice has closed. This minimizes liquid hammer.

When the coil is currentless, the main orifice, seat plate (12) and pilot orifice (on the pilot plate (11)) are closed. The pilot orifice and main orifice are held closed by the armature spring force and the differential pressure between inlet and outlet sides.

When current is applied to the coil, the armature (9) is drawn up into the magnetic field and thus lifts the pilot plate (11) and opens for the pilot orifice so that the de-energising of the servo chamber (A) starts and the pressure is relieved to the level of the outlet side. As the inlet pressure that acts on the bottom of the piston (13) now is higher than the pressure in the servo chamber (A), the piston is moved upwards and lifts both the pilot plate (11) and the seat plate (12). When the seat plate is lifted, the main orifice opens for full flow.

Therefore a minimum differential pressure of 0.02 bar is necessary to open the valve and keep it open.

When the current to the coil is switched off, the spring (8) forces the armature (9) down towards the pilot plate (11). The pressure in the servo chamber (A) increases and the piston will no longer be able to hold the seat plate (12) in lifted position, by which the main orifice closes. The armature (9) continues its downwards movement until the pilot orifice on the pilot plate (11) is fully closed.

Material specifications

No.	Description	Material	Alloys	Mat. no.	Standard		
					W.no.	DIN	EN
1, 5	Bi-metallic tube	Stainless steel / Cu	-	-	-	-	-
2, 4	Solder ring	Silver	L-Ag 15P	CP102	-	1044	1044
3	Valve body	Brass	CuZn40Pb2	CW617N	2.0402	17672-1	12165
6	Union nut	Brass	CuZn39Pb2	CW612N	2.0380	17672-1	12164
7	Armature tube	Stainless steel	X6CrMoS17	-	1.4105	-	10088
8	Spring	Spring wire stainless	X10CrNi18-8	-	1.4310	-	10088
9	Armature	Stainless steel	X4CrMoS18	-	1.410SIL	-	10088
10	Support ring	Teflon	PTFE	-	-	-	-
11	Pilot plate	Thermoplast	PEEK	-	-	-	-
12	Seat plate	Teflon	PTFE	-	-	-	-
13	Piston	Brass	CuZn39Pb2	CW612N	2.0380	17672-1	12164

**Dimensions [in.]
and weights [lbs]**

EVU 1, EVU 2, EVU 3, EVU 4, EVU 5, EVU 6 mounted with coil with 0.25 in. US spade

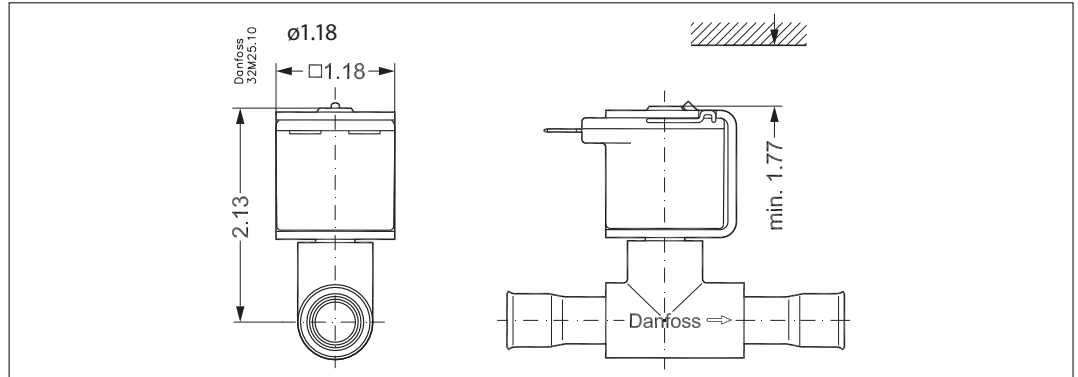

EVU 1, EVU 2, EVU 3, EVU 4, EVU 5, EVU 6

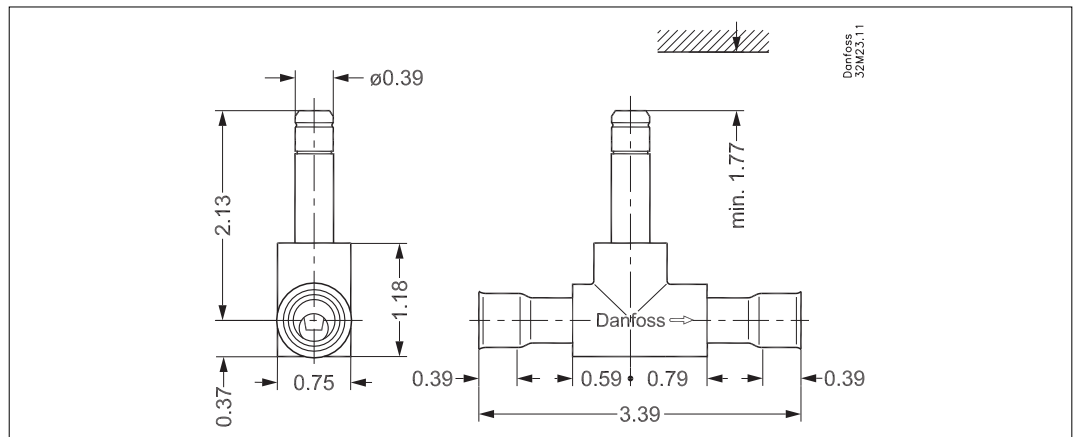

EVU 8

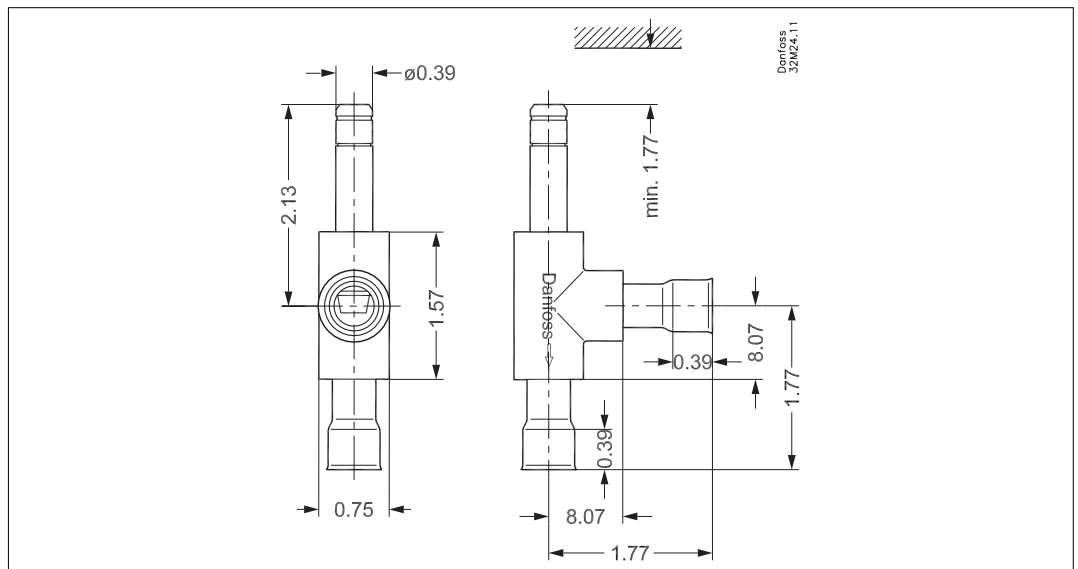

Net weight of coil:
8 W: approx. 0.22 lbs
Net weight of valve:
approx 0.22 lbs

Note: the drawings are only representative.

Danfoss can accept no responsibility for possible errors in catalogues, brochures and other printed material. Danfoss reserves the right to alter its products without notice. This also applies to products already on order provided that such alterations can be made without subsequential changes being necessary in specifications already agreed. All trademarks in this material are property of the respective companies. Danfoss and the Danfoss logotype are trademarks of Danfoss A/S. All rights reserved.