

Fact Sheet

DSE FLEX

Compact substation, HE 560 kW, DHW 590 kW



Application

New generation substation is suitable for the already proven flexible, efficient and economical infrastructure of a low carbon city, a District Heating network. It is an exclusive solution designed to optimally fulfil specific requests and stringent requirements for district heating. By use of the Danfoss dimensioning program you can find out if the application you need fits DSE FLEX.

Construction

DSE FLEX is a compact substation platform designed for indirect district heating with up to 3 circuits with possibility to make combinations between modules if more circuits are required. The new generation substation is designed to be floor mounted, it keeps the robustness and friendly / appealing outlook of the old product with the advantage of a lighter profile, smaller size and designed for a faster and safer transport. DSE FLEX usually does not exceed when delivered 1.5m height. However if the situation requires the substation height can be reduced to 1.2m. (See the Hauling instructions). DSE FLEX is designed always with the HE heat exchanger and circuit on the left side and the DHW heat exchanger an circuit on the right side when facing the substation. Piping can be prepared

in the room to fit this construction before the substation is delivered. The reduced size of the base frame and layout offers DSE FLEX the smallest foot print in its product class. Most of the 2 circuit variants are not larger than 1 Euro Pallet. The compact size does not minimize the access to key service components. The connections are very low and orientated upwards, making it easy to connect the substation in all directions. The electrical panel is mounted always on the right side when facing the substation. The bracket of the electrical panel is adjustable 90 deg in rotation and in vertical direction up to 500mm. The substation piping construction is realized with automatic welding machines to ensure the highest welding quality, the quality of this product is further more ensured by the GGG40.3 casted parts on Heating and CC752S casted parts on Domestic Hot Water. On request the substation can be delivered with full insulation PUR.

Equipment

Danfoss substation is equipped with various high quality components produced by Danfoss. They ensure high comfort, high quality performance during operation and energy saving.

FEATURES AND BENEFITS

- Compact size for an easy transport and installation
- The adjustable feet are from construction inside the profile
- Hauling instructions for a faster and safer transport
- The height of the connections is very low
- Electronic controller for heating and domestic hot water systems with access to ECL Portal
- Advanced gasket system primary side
- Fast and reliable delivery
- Substation with high efficiency brazed plate heat exchanger with the new microplate technology
- Easy access to key service components
- Danfoss substations and heat exchangers are manufactured according to European Pressure Directive PED

The components are tested and approved especially for DEN applications. All Danfoss components in control loop are tuned together so the optimum performance is guaranteed. We mention ECL DH controller which gives access to an online portal, a full range of Microplate Heat Exchanger that thanks to the unique plate design, reduces pressure loss up to 35%, the Danfoss pressure balanced control valves VM and the DHW control proven solution AVQM. DSE FLEX means flexible for your application, that is why we allow also other components inside this substation with out minimizing the construction and installation advantages.

Information needed for a quotation

Heat capacities
Temperature program
Permissible pressure losses in the heat exchangers / substation
Primary pressure difference available
Pressure losses in secondary circuits
Flow-through hot water circulation
Other information about other required components.

CIRCUIT DIAGRAM – EXAMPLE

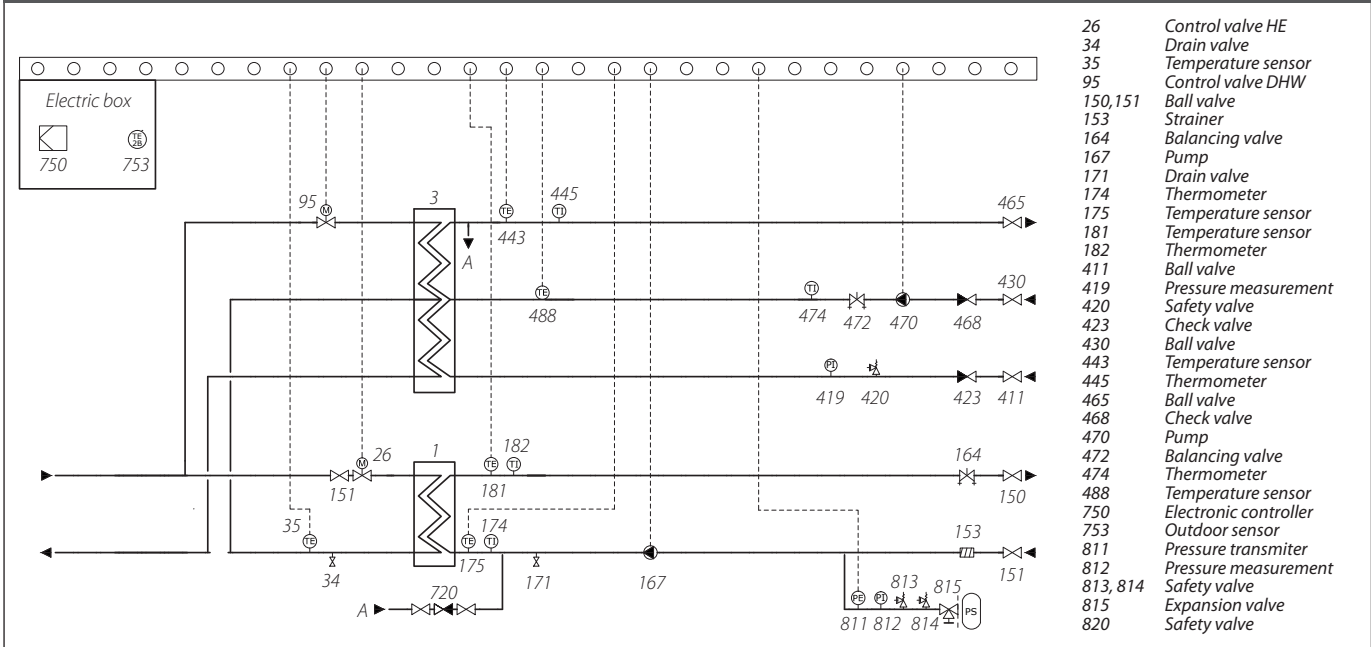

Technical parameters

Primary side

Maximum temperature: 135 °C
 Nominal pressure: PN 16
 Diameter: DN 25/50

Heating

Maximum temperature: 90 °C
 Nominal pressure: PN 6
 Diameter: DN 25/65

Domestic Hot Water

Maximum temperature: 90 °C
 Nominal pressure: PN 10
 Diameter: DN 25/50

Max dimensions (mm)

Width / Height / Depth (1F): 1200 / 1500 / 650 mm
 Width / Height / Depth (2F): 1500 / 1500 / 650 mm
 Width / Height / Depth (3F): 2000 / 1500 / 650 mm

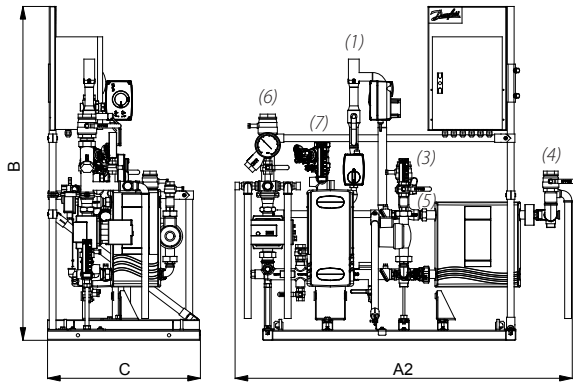

Weight (incl. packing)

1-circuit station: max. 164 kg
 2-circuit station: max. 210 kg
 3-circuit station: max. 322 kg

Connections:

1. District Heating Supply
2. District Heating Return
3. Domestic Hot Water
4. Domestic Cold Water
5. Circulation
6. Heating Supply
7. Heating Return

CAPACITY, WEIGHT AND DIMENSIONS

Capacity [kW]			Pipe diameter				External dimensions (max)					Weight		
Heating 1 115-43/ 40-70	Heating 2 115-63/ 60-80	DHW 70-20/ 10-58	Heating 1 [DN]	Heating 2 [DN]	Cold/ warm water [DN]	DHW circu- lation [DN]	Length (1 circuit) [mm]	Length (A2) [mm]	Length (3 circuit) [mm]	Height (B) [mm]	Depth (C) [mm]	Weight 1 circuit [kg]	Weight 2 circuits [kg]	Weight 3 circuits [kg]
60	40	70	25	25	25	15	900	1000	1600	1300	500	54	71	99
95	60	100	25	25	25	15	900	1100	1600	1300	500	59	77	109
120	80	150	32	32	25	15	900	1150	1700	1300	500	65	83	119
150	100	195	32	32	32	20	900	1150	1700	1300	500	70	88	127
190	125	245	40	40	32	20	950	1200	1750	1300	610	87	110	170
235	160	300	40	40	40	25	950	1200	1750	1300	610	102	129	199
295	200	380	50	50	40	25	1150	1400	1900	1400	650	110	140	215
370	245	395	50	50	50	25	1150	1400	1900	1400	650	141	180	276
560	410	590	65	65	50	32	1200	1500	2000	1500	650	164	210	322

These are only few examples of all the possible combinations. Depending on the customer requirements, type of heat exchangers, application, DN combinations, etc. the dimensions may vary. Depth dimension C is considered for 2 and 3 circuit stations. Height dimension B is considered with the electrical box in the minimum height position and the heating pump on the return line. Maximum capacity is determined by temperature, allowable pressure drops and local regulations.

Danfoss A/S

Heating Segment • heating.danfoss.com • +45 7488 2222 • E-Mail: heating@danfoss.com

Danfoss can accept no responsibility for possible errors in catalogues, brochures and other printed material. Danfoss reserves the right to alter its products without notice. This also applies to products already on order provided that such alterations can be made without subsequential changes being necessary in specifications already agreed. All trademarks in this material are property of the respective companies. Danfoss and all Danfoss logotypes are trademarks of Danfoss A/S. All rights reserved.