

ENGINEERING
TOMORROW



Service Manual

Steering Valve

EHPS and EHPS with OLS 320



Revision history

Table of revisions

Date	Changed	Rev
July 2016	Updated EHPS spare parts list	0102
June 2015	First version	AA

Contents

Safety Precautions

Safety precautions.....4

Service Literature

Symbols Used in Danfoss Literature.....5
 EHPS versions.....5

Exploded view

EHPS type 0, 1 and 2 exploded view.....6
 EHPS spare parts list.....7
 EHPS with flanged on OLS 320 exploded view.....9
 EHPS and OLS 320 spare parts list.....10
 Seal kits and spare parts for EHPS and OLS 320.....11

Tools

Tools for EHPS.....12

Disassembly and assembly

Disassembly of EHPS.....13
 Assembly of EHPS.....23
 Disassembly of OLS 320 and priority valve spool of EHPS.....31
 Assembly of OLS 320 and priority valve spool of EHPS.....35

Testing

Testing of EHPS.....39
 Set up for testing the EHPS.....39
 Steering test using pilot steering unit type OSPCX CN.....39
 Pilot relief valve for EHPS.....40
 Neutral positioning test, OSP part for EHPS.....40
 Steering and neutral positioning test, EH part with EHPS.....40
 Manual steering with EHPS.....40
 Testing of EHPS with OLS 320.....41
 Set up for testing the EHPS with OLS 320.....41

Safety Precautions

Safety precautions

Always consider safety precautions before beginning a service procedure. Protect yourself and others from injury. Take the following general precautions whenever servicing a hydraulic system.

 **Warning**

Unintended Machine Movement

Unintended movement of the machine or mechanism may cause injury to the technician or bystanders. To prevent unintended movement, secure the machine or disable / disconnect the mechanism while servicing.

 **Warning**

Flammable Cleaning Solvents

Some cleaning solvents are flammable. To eliminate the risk of fire, do not use cleaning solvents in an area where a source of ignition may be present.

 **Warning**

Fluid under Pressure

Escaping hydraulic fluid under pressure can have sufficient force to penetrate your skin causing serious injury and/or infection. This fluid may also be hot enough to cause burns. Use caution when dealing with hydraulic fluid under pressure. Relieve pressure in the system before removing hoses, fittings, gauges, or components. Never use your hand or any other body part to check for leaks in a pressurized line. Seek medical attention immediately if you are cut by hydraulic fluid.

 **Warning**

Personal Safety

Protect yourself from injury. Use proper safety equipment, including safety glasses, at all times.

 **Warning**











Product Safety

Steering valves are safety components and therefore it is extremely important that the greatest care is taken when servicing these products. There is not much wear on a steering valve and therefore they normally outlast the application they are built into. Therefore the only recommended service work on steering valves is:

- Changing seals and o-rings
 - Disassemble, clean, and assemble if contaminated
 - Hydraulic testing, including valve setting
-

Service Literature

Symbols Used in Danfoss Literature

-  = Non removable part, use a new part
-  = External hex head
-  = Internal hex head
-  = Lubricate with hydraulic fluid
-  = Inspect for wear or damage
-  = Note correct orientation
-  = Mark orientation for reinstallation
-  = Torque specification
-  = Press in - press fit
-  = Pull out with tool - press fit

EHPS versions

This service literature is valid for:

- EHPS type 0: EHPS without PVE actuation module
- EHPS type 1 and 2: EHPS with PVE actuation module
- EHPS with flanged on priority valve module, OLS 320

Exploded view

EHPS type 0, 1 and 2 exploded view

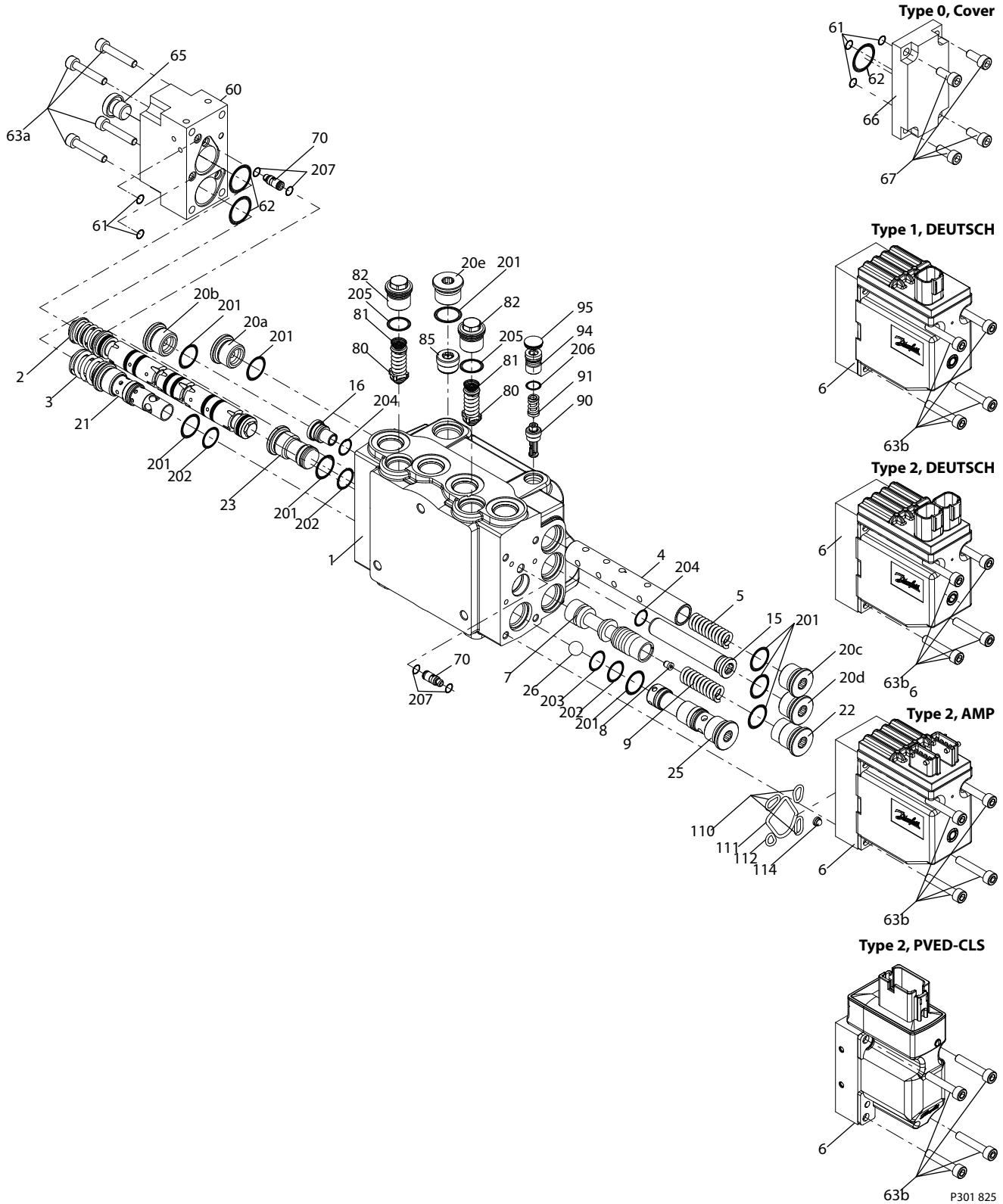

Exploded view
EHPS spare parts list
EHPS spare parts

EHPS	Number per unit	Item	Tightening torque
Valve block	1	1	-
Spool with spring, directional	1	2	-
Spool with spring, pilot - OSP	1	3	-
Spool, metering	1	4	-
Spring	1	5	-
PVE	1	6	-
Spool, priority valve	1	7	-
Orifice, Dynamic	1	8	3.5±0.5 Nm
Spring	1	9	-
Tube	1	15	10±0.5 Nm
Plug	1	16	10±0.5 Nm
Plug	1	20a	40±3 Nm
Plug	1	20b	40±3 Nm
Plug	1	20c	40±3 Nm
Plug	1	20d	40±3 Nm
Plug	1	20e	40±3 Nm
Bushing	1	21	40±3 Nm
Plug	1	22	40±3 Nm
Plug	1	23	40±3 Nm
Plug	1	25	20±3 Nm
Ball	1	26	-
Cover	1	60	-
O-ring Ø5.0 x Ø1.5 mm	5	61	-
O-ring Ø27.5 x Ø1.5 mm	3	62	-
Screw, M6, l=33 mm	4	63a	8±0.5 Nm
Screw, M6, l=33 mm	4	63b	8±0.5 Nm
Plug w. O-ring	1	65	-
Cover, EHPS type 0	1	66	-
Screw, M6, l=15 mm, EHPS type 0	4	67	8±0.5 Nm
Shuttle valve	2	70	-
Shock valve	2	80	-
Spring, conical	2	81	-
Plug	2	82	40±3 Nm
Check valve	1	85	25±5 Nm
Seat for pilot relief valve	1	90	20±3 Nm
Cone with spring for pilot relief valve	1	91	-
Adjusting screw for pilot relief valve	1	94	-
Plug	1	95	-
O-ring Ø10.0 x Ø2.0 mm	3	110	-
O-ring Ø30.0 x Ø2.5 mm	1	111	-
O-ring Ø8.0 x Ø2.0 mm	1	112	-
Filter	1	114	-
O-ring Ø17.4 x Ø2.1 mm	9	201	-

Exploded view

EHPS spare parts (continued)

EHPS	Number per unit	Item	Tightening torque
O-ring Ø15.0 x Ø1.5 mm	3	202	-
O-ring Ø14.0 x Ø1.5 mm	1	203	-
O-ring Ø10.0 x Ø2.0 mm	2	204	-
O-ring Ø15.6 x Ø1.78 mm	2	205	-
O-ring Ø9.0 x Ø2.0 mm	1	206	-
O-ring Ø5.0 x Ø1.0 mm	4	207	-

Exploded view

EHPS with flanged on OLS 320 exploded view

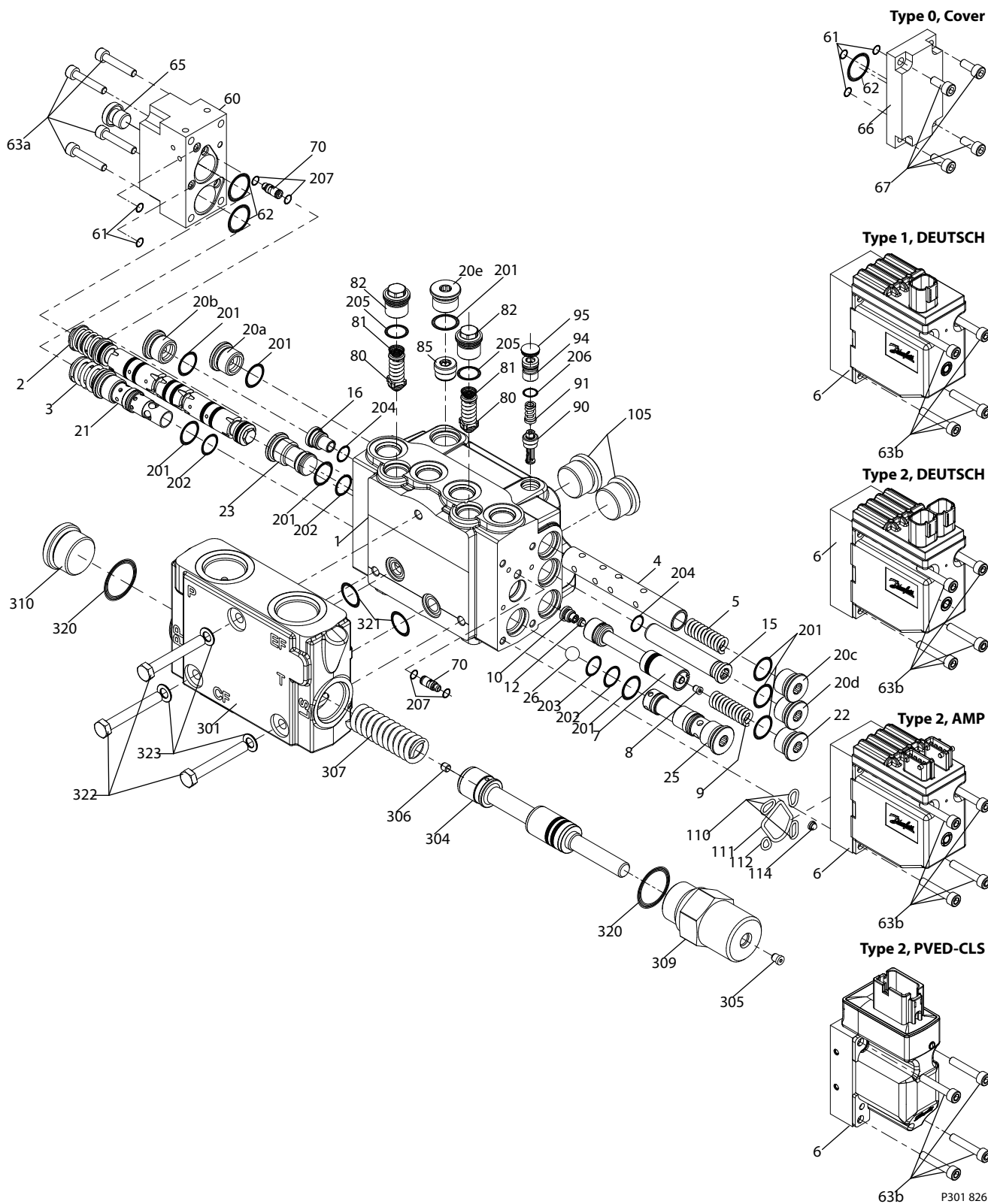

Exploded view
EHPS and OLS 320 spare parts list
EHPS spare parts

EHPS	Number per unit	Item	Tightening torque
Valve block	1	1	-
Spool with spring, directional	1	2	-
Spool with spring, pilot - OSP	1	3	-
Spool, metering	1	4	-
Spring	1	5	-
PVE	1	6	-
Spool, priority valve	1	7	-
Orifice, Dynamic	1	8	3.5±0.5 Nm
Spring	1	9	-
Orifice, PP	1	10	3.5±0.5 Nm
Filter	1	12	-
Tube	1	15	10±0.5 Nm
Plug	1	16	10±0.5 Nm
Plug	1	20a	40±3 Nm
Plug	1	20b	40±3 Nm
Plug	1	20c	40±3 Nm
Plug	1	20d	40±3 Nm
Plug	1	20e	40±3 Nm
Bushing	1	21	40±3 Nm
Plug	1	22	40±3 Nm
Plug	1	23	40±3 Nm
Plug	1	25	20±3 Nm
Ball	1	26	-
Cover	1	60	-
O-ring Ø5.0 x Ø1.5 mm	5	61	-
O-ring Ø27.5 x Ø1.5 mm	3	62	-
Screw, M6, l=33 mm	4	63a	8±0.5 Nm
Screw, M6, l=33 mm	4	63b	8±0.5 Nm
Plug w. O-ring	1	65	-
Cover, EHPS type 0	1	66	-
Screw, M6, l=15 mm, EHPS type 0	4	67	8±0.5 Nm
Shuttle valve	2	70	-
Shock valve	2	80	-
Spring, conical	2	81	-
Plug	2	82	40±3 Nm
Check valve	1	85	25±5 Nm
Seat for pilot relief valve	1	90	20±3 Nm
Cone with spring for pilot relief valve	1	91	-
Adjusting screw for pilot relief valve	1	94	-
Plug	1	95	-
Plug	2	105	40±3 Nm
O-ring Ø10.0 x Ø2.0 mm	3	110	-
O-ring Ø30.0 x Ø2.5 mm	1	111	-

Exploded view

EHPS spare parts (continued)

EHPS	Number per unit	Item	Tightening torque
O-ring Ø8.0 x Ø2.0 mm	1	112	-
Filter	1	114	-
O-ring Ø17.4 x Ø2.1 mm	9	201	-
O-ring Ø15.0 x Ø1.5 mm	3	202	-
O-ring Ø14.0 x Ø1.5 mm	1	203	-
O-ring Ø10.0 x Ø2.0 mm	2	204	-
O-ring Ø15.6 x Ø1.78 mm	2	205	-
O-ring Ø9.0 x Ø2.0 mm	1	206	-
O-ring Ø5.0 x Ø1.0 mm	4	207	-

OLS 320 spare parts

OLS 320	Number per unit	Item	Tightening torque
Housing	1	301	-
Spool	1	304	-
Orifice, LS	1	305	1±0.1 Nm
Orifice, PP	1	306	3.5±0.5 Nm
Spring	1	307	-
Plug, LS	1	309	50±5 Nm
Plug, PP	1	310	50±5 Nm
O-ring Ø29.6 x Ø2.9 mm	2	320	-
O-ring Ø16.0 x Ø2.5 mm	2	321	-
Screw	3	322	28±2 Nm
Washer	3	323	-

Seal kits and spare parts for EHPS and OLS 320

Spare parts list	Code No.	Item
Seal kit, EHPS	150H4021	61, 62, 201, 202, 203, 204, 205, 206, 207
Seal kit OLS 320	152B6200	320
Seal kit for block ass.	11008362	321
Seal kit for PVE/cover	157B4997	110, 111, 112, 114
Shuttle valve, 2 pcs	11007949	70

Tools

Tools for EHPS

Holding tool: It is recommended to use appropriate steel plate with mounting holes 3x Ø 10 mm matching mounting thread holes, A or B on one of the two mounting sides of EHPS.

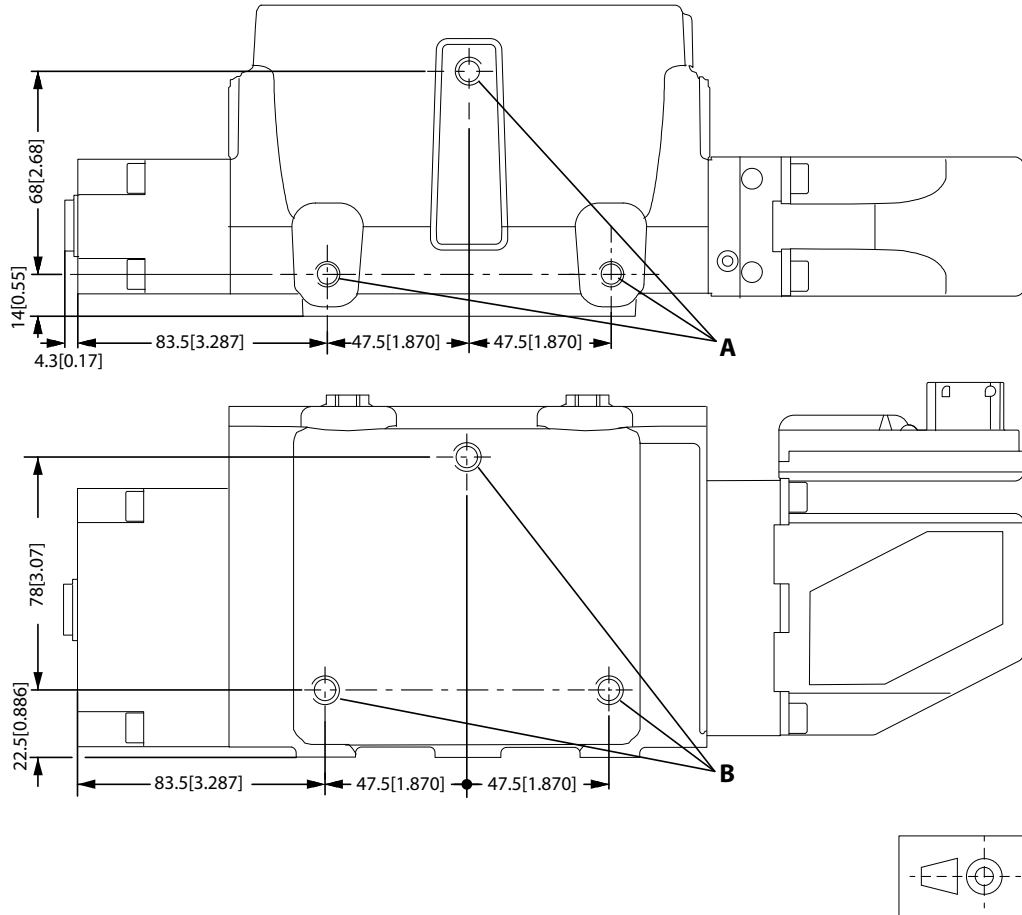

150H11.11

	A	B
All versions	M8 • 1.25, 10 mm [0.39 in] deep	M8 • 1.25, 10 mm [0.39 in] deep

- Torque wrench 0 - 70 Nm.
- 6 and 13 mm socket spanner.
- 5, 2x 8, 12 and 14 mm Hex keys.
- T50 Torx key
- 2 mm screwdriver.
- 13 - 17 - 19 - 36 - 41 mm ring spanner.
- Pliers
- Inside circlip pliers.
- Tweezers

[These tools are not available from Danfoss.](#)







F302 183

Disassembly and assembly

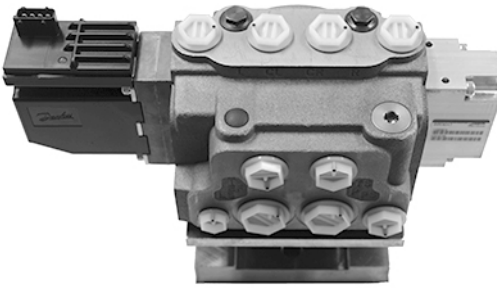

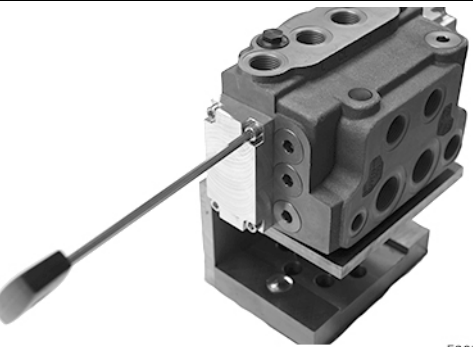
Disassembly of EHPS

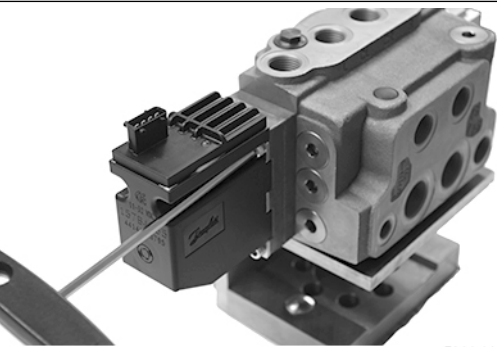
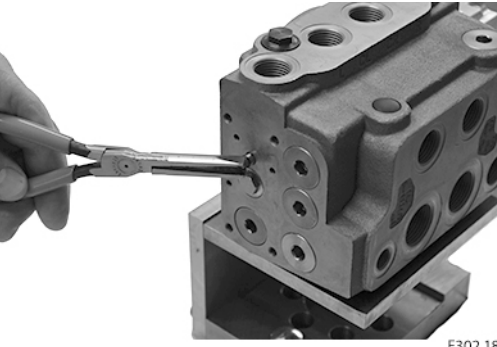
Disassembly of EHPS

<p>Place the unit on the holding tool.</p>	 <p>F302 184</p>
<p>EHPS type 0 (without PVE): Screw out the 4 screws (67) for cover (66) using a 5 mm  Hex key. Remove the cover (66). O-rings (61 and 62) are fitted to cover (66). <u>Shuttle valves (70) are not present in EHPS type 0.</u></p>	 <p>F302 185</p>
<p>EHPS type 1 and type 2: Screw out the 4 screws (63b) for PVE (6) using a 5 mm  Hex key. Remove the PVE (6). O-rings (110, 111 and 112) and filter (114) are fitted to the mounting surface of PVE. Shuttle valve (70) is fitted into the mounting surface of PVE (6) and housing (1), it will stay in one of the 2 elements when removing the PVE from the EHPS housing.</p>	 <p>F302 186</p>  <p>F302 187</p>

Disassembly and assembly

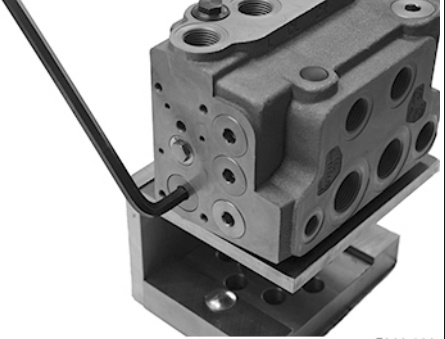
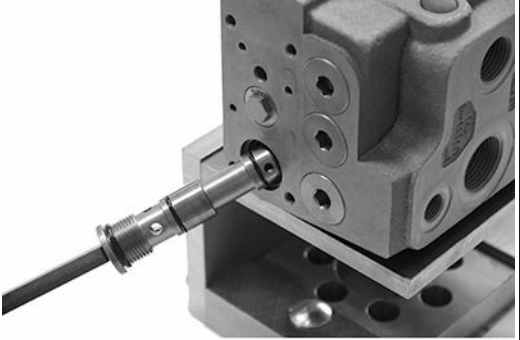
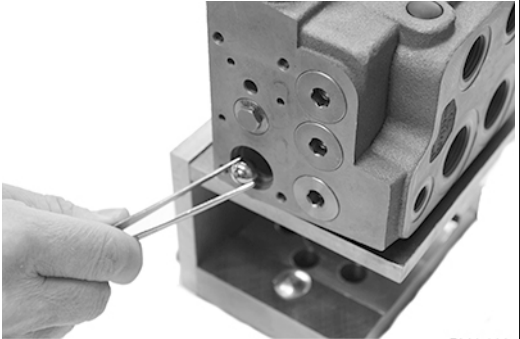
Disassembly of EHPS (continued)

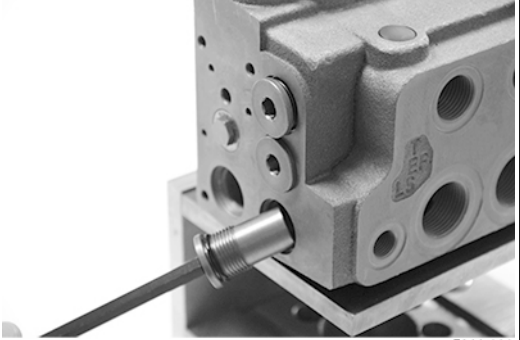
<p>Screw out the plug (25) using an 8 mm  Hex key. O-rings (201, 202 and 203) are fitted to the bushing (21).</p>	 <p style="text-align: right;">F302 188</p>  <p style="text-align: right;">F302 189</p>
<p>Remove the ball (26).</p>	 <p style="text-align: right;">F302 190</p>
<p>Screw out the plugs (20c, 20d and 22) using an 8 mm  Hex key. O-rings (201) are fitted to the plugs.</p>	 <p style="text-align: right;">F302 191</p>

Disassembly and assembly

Disassembly of EHPS (continued)

Remove the spring (5).

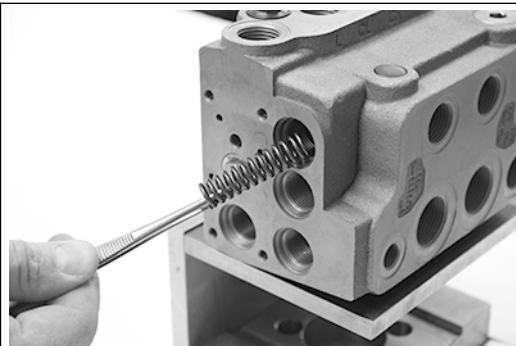

Remove the spring (9).

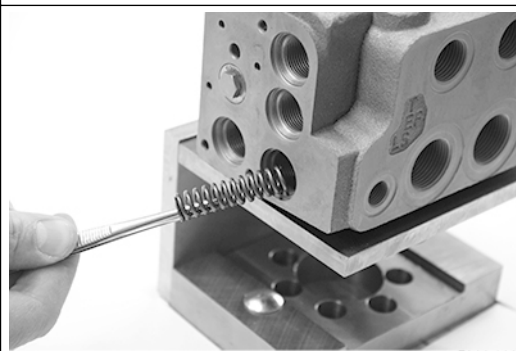

Disassembly and assembly

Disassembly of EHPS (continued)

Screw out the 4 screws (63a) for cover (60) using a 5 mm Hex key.
 Remove the cover (60).
 O-rings (61 and 62) are fitted to the mounting surface of cover.

EHPS type 1 and 2:

Shuttle valve (70) is fitted into the mounting surface of cover (60) and housing (1), it will stay in one of the 2 elements when removing the cover from the EHPS housing.

Plug (65) is fitted to cover (60). It is recommended not to screw out plug (65).

EHPS type 0 normally has no shuttle valves (70).

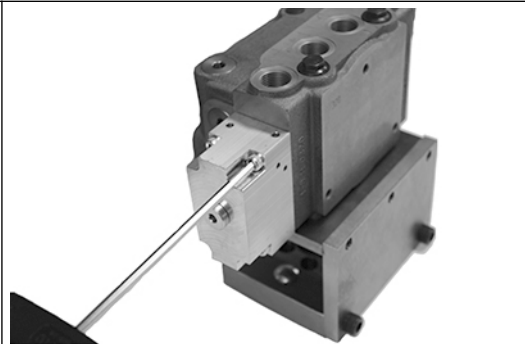

F302 194

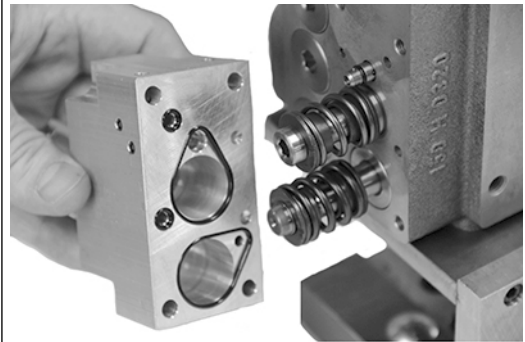

F302 195

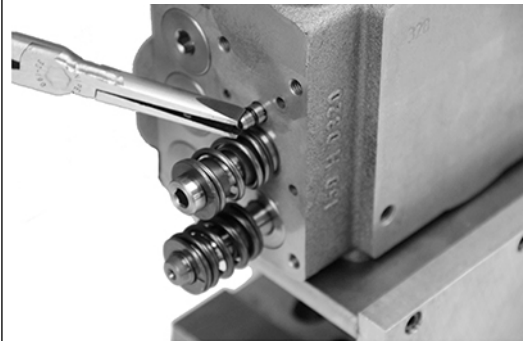

F302 196

Remove the directional spool with spring (2).

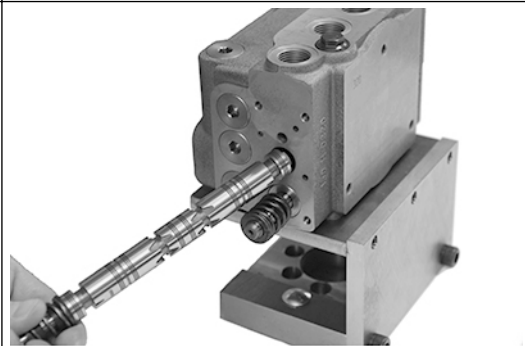

F302 197

Disassembly and assembly

Disassembly of EHPS (continued)

Remove the pilot spool with spring (3).

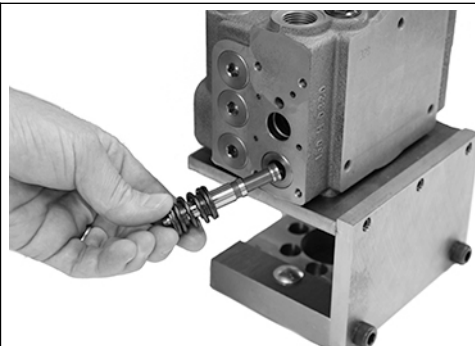

F302 198

Screw out the bushing (21) using a 12 mm  Hex key. O-rings (201 and 202) are fitted to the bushing (21).

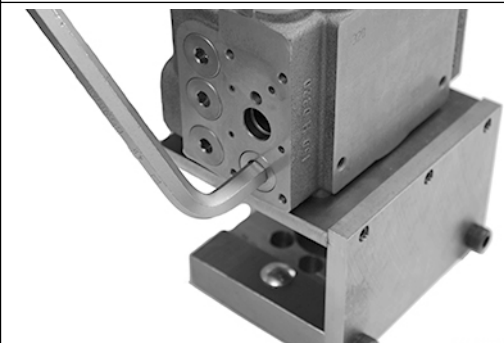

F302 199

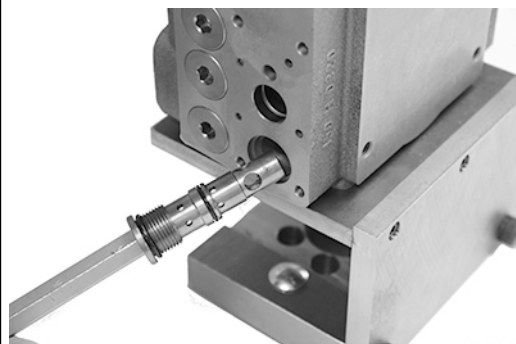

F302 200

Disassembly and assembly

Disassembly of EHPS (continued)

Screw out the plugs (20a, 20b and 23) using an 8 mm  Hex key.
 O-rings (201) are fitted to the plugs (20a and 20b). O-rings (201 and 202) are fitted to the plug (23).

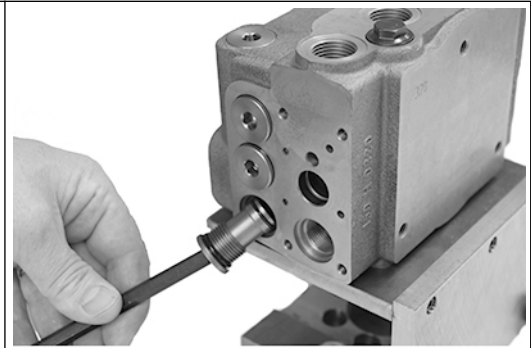

F302 201

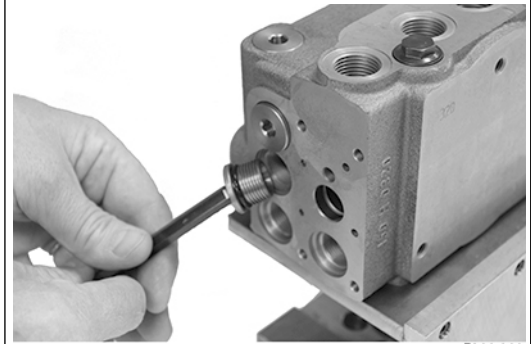

F302 202

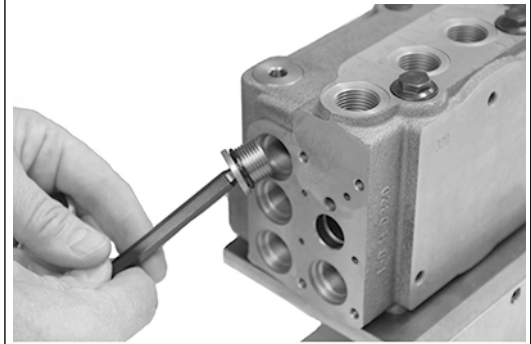

F302 203

From the PVE end (type 1 and 2) or cover (66) end (type 0):
 Remove the metering spool (4).

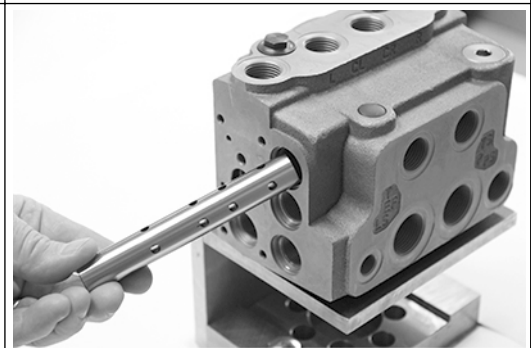

F302 204

Disassembly and assembly

Disassembly of EHPS (continued)

Remove the priority valve spool (7).
 Orifice, dynamic (8) is screwed into spool (7).

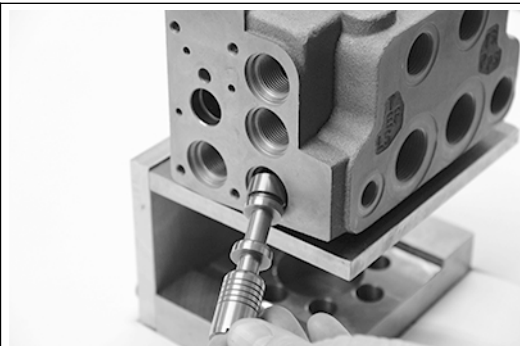

F302 205

Screw out the plug (16) of tube (15) using two 8 mm 
 Hex keys: one in plug and one in tube end.

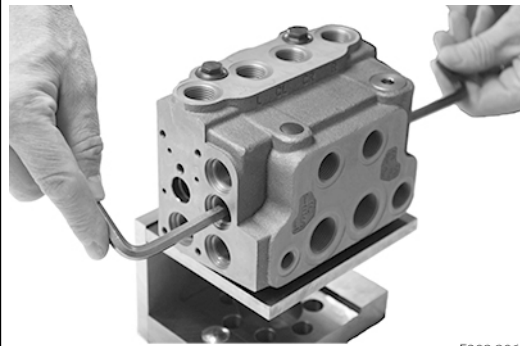

F302 206

Remove plug (16) and tube (15).
 O-rings (204) are fitted to the plug (16) and the tube (15).

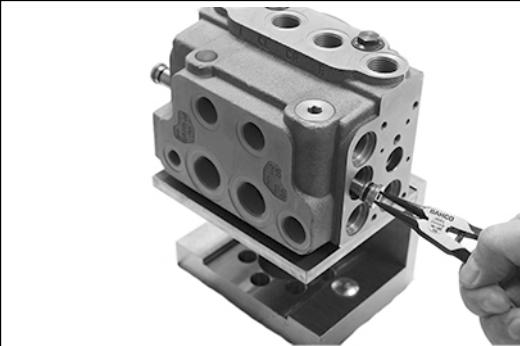



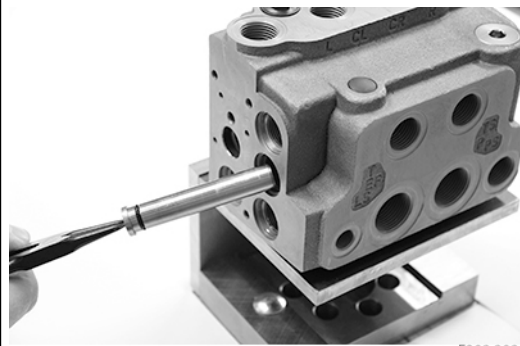

F302 207



F302 208

Disassembly and assembly

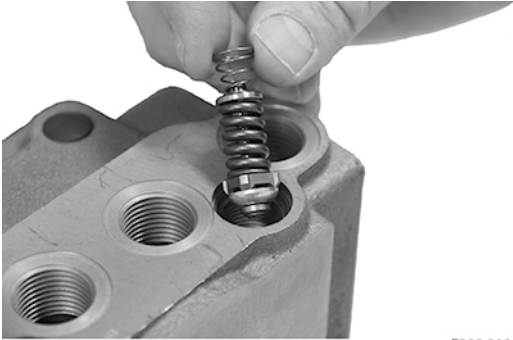
Disassembly of EHPS (continued)

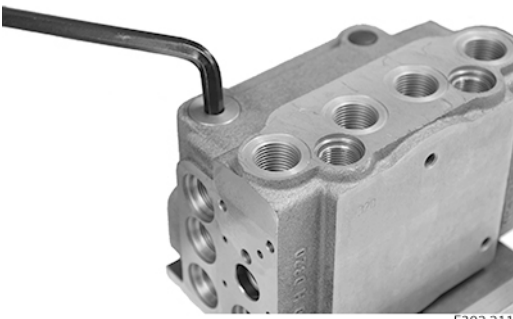
<p>Screw out the plugs (82) using a 13 mm  socket or ring spanner. O-rings (205) are fitted to the plugs (82).</p>	 <p style="text-align: right;">F302 209</p>
<p>Remove the shock valves (80) with conical springs (81).</p>	 <p style="text-align: right;">F302 210</p>
<p>Screw out the plug (20e) using an 8 mm  Hex key. O-ring (201) is fitted to the plug (20e)</p>	 <p style="text-align: right;">F302 211</p>

Disassembly and assembly

Disassembly of EHPS (continued)

Screw out the check valve (85) using an T50  Torx key.

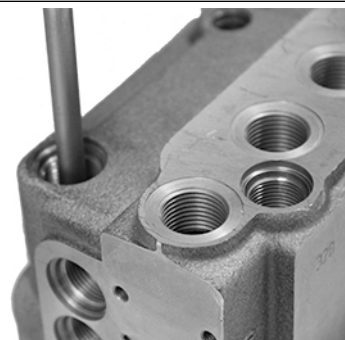

F302 212

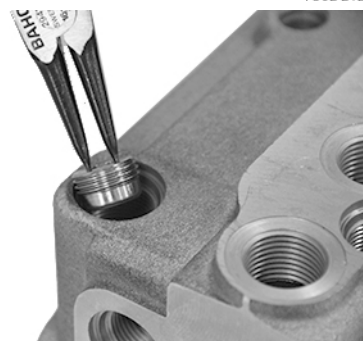

F302 213

Remove plug (95) using a 2 mm screw driver.

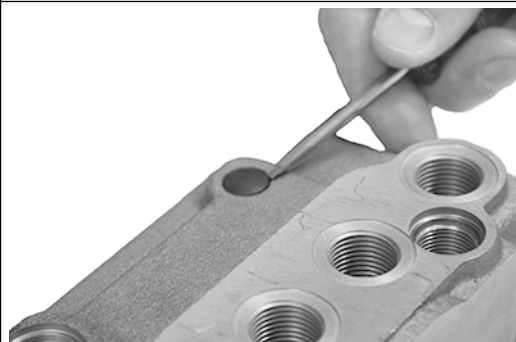

F302 214

Screw out the adjusting screw (94) using an 6 mm  Hex key.
 O-ring (206) is fitted to the screw (94).



F302 215

Disassembly and assembly

Disassembly of EHPS (continued)

Remove the spring with cone (91).

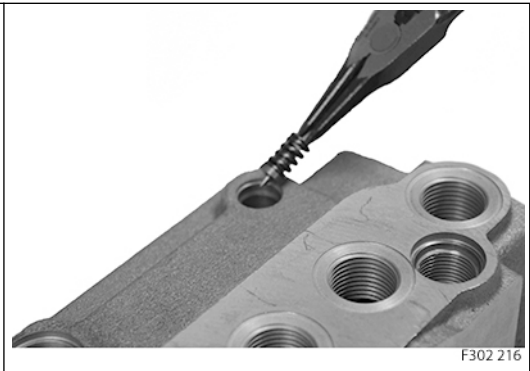

F302 216

Screw out the seat (90) using a 6 mm  socket spanner.

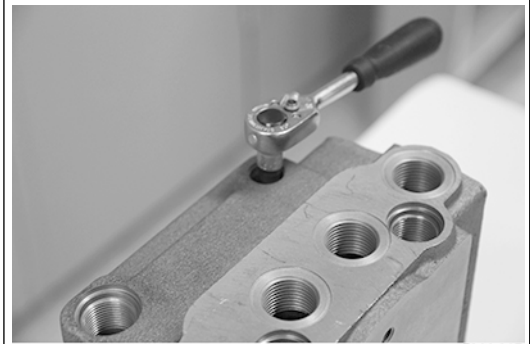

F302 217

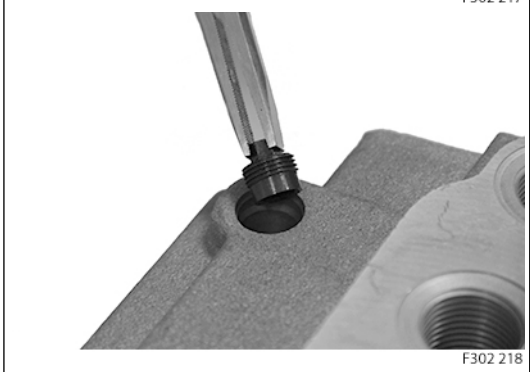

F302 218

Now the EHPS is completely dismantled.

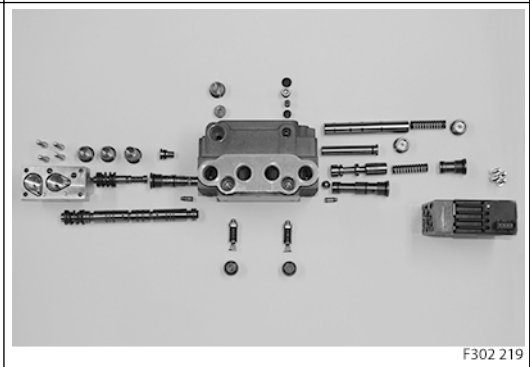

F302 219

Cleaning:

Clean all parts carefully in Shellsol K or similar cleaner fluid.

Inspection and replacement:





Replace all seals and washers.

Check all parts carefully and make any replacements as is necessary.

Disassembly and assembly



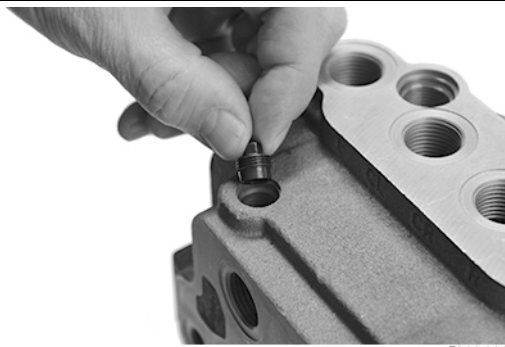
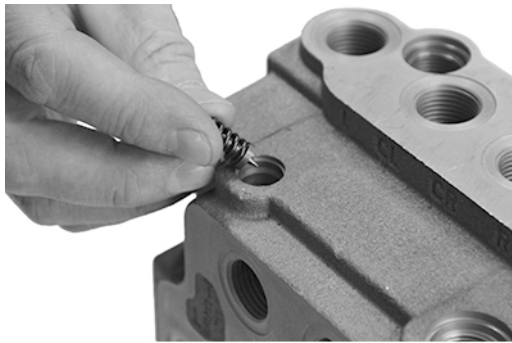

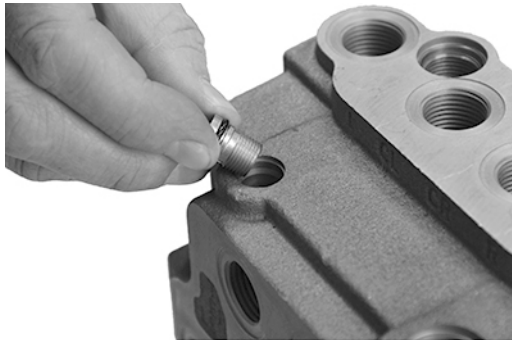



Assembly of EHPS

Assembly of EHPS

<p>Place the housing on the holding tool.</p>	 <p>F302 220</p>
<p>Screw in the seat (90) using a 6 mm  socket spanner.  20 ±3 Nm.</p>	 <p>F302 221</p>
<p>Place the spring with cone (91).</p>	 <p>F302 222</p>
<p>Place O-ring (206) on screw (94). Screw in the adjusting screw (94) using a 6 mm  Hex key. After entire assembly of the steering valve, make the pressure setting on a test panel according to valve setting specification, see Testing of EHPS on page 39. Insert plastic protection plug (95).</p>	 <p>F302 223</p>

Disassembly and assembly

Assembly of EHPS (continued)

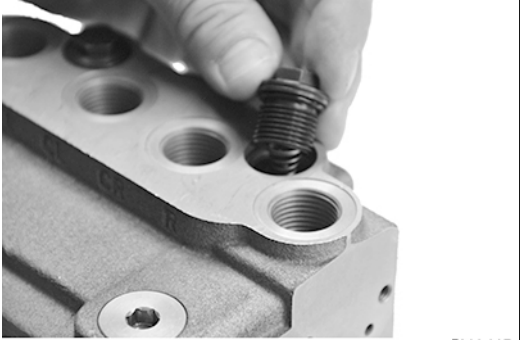
<p>Screw in the check valve (85) using an T50  Torx key.  25 ±5 Nm.</p>	 <p style="text-align: right;">F302 224</p>
<p>Place O-ring (201) on to the plug (20e). Screw in the plug (20e) using an 8 mm  Hex key.  40 +/- 3 Nm.</p>	 <p style="text-align: right;">F302 225</p>
<p>Insert the shock valves (80) with conical springs (81).</p>	 <p style="text-align: right;">F302 226</p>
<p>Place O-rings (205) on the plugs (82). Screw in the plugs (82) using a 13 mm  socket or ring spanner.  40 ±3 Nm.</p>	 <p style="text-align: right;">F302 227</p>

Disassembly and assembly

Assembly of EHPS (continued)

Place O-rings (204) on the plug (16) and the tube (15). Insert plug (16) and tube (15) and tighten using two 8 mm Hex keys: one in plug and one in tube end.
 10 ±0.5 Nm.

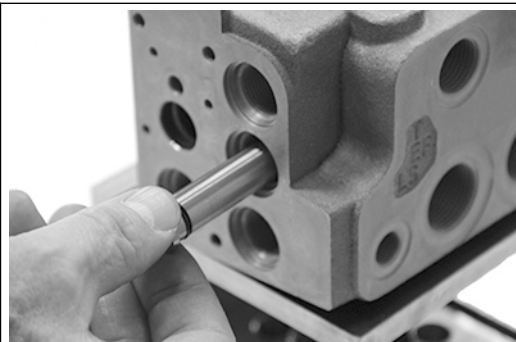

F302 228

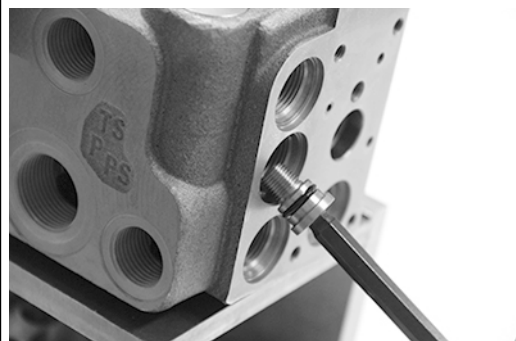

F302 229

Assemble priority valve spool (7) with the dynamic orifice (8) using a 3 mm Hex key.
 3.5 ±0.5 Nm.
 Insert the priority valve spool (7) with the spring bore pointing outwards.

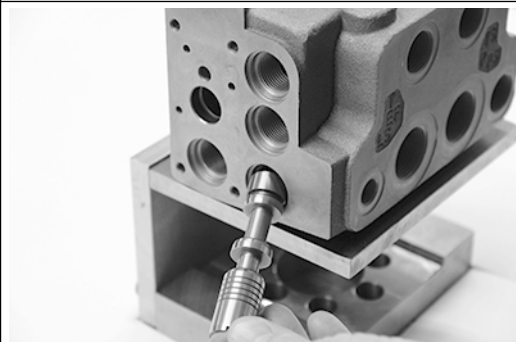

F302 205

Insert the metering spool (4) with the spring bore pointing outwards/flat end pointing inwards.



F302 230

Disassembly and assembly

Assembly of EHPS (continued)

From the end cover (60) end:
Place O-ring (201) on to the plugs (20a and 20b, the two upper plugs).
Place O-rings (201 and 202) on the plug (23, the lower plug).

Screw in the plug (20a, 20b and 23) using an 8 mm Hex key.

40 ±3 Nm.

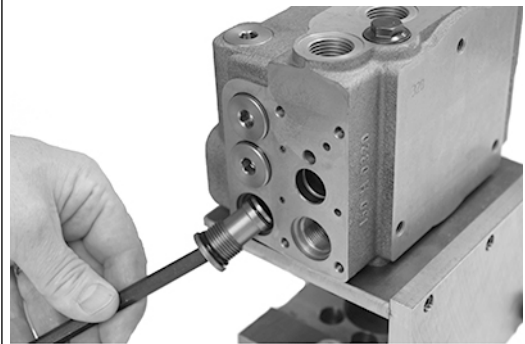

F302 201

Place O-rings (201 and 202) to the bushing (21). Screw in the bushing (21) using a 12 mm Hex key.

40 ±3 Nm.

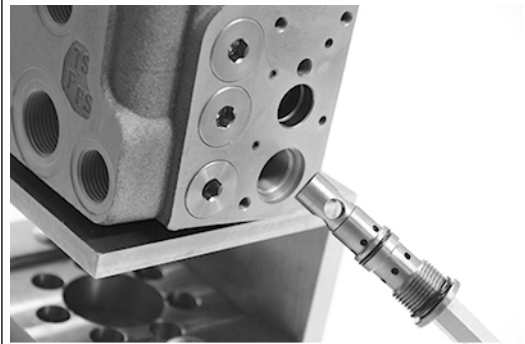

F302 231

Insert the pilot spool w. spring (3).

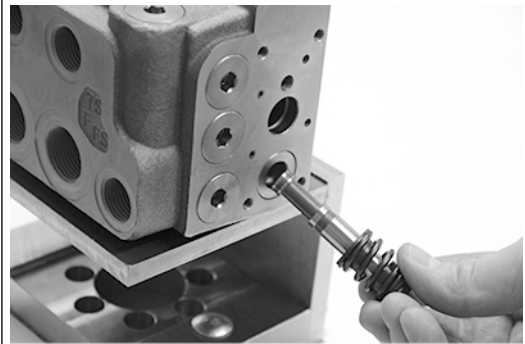

F302 232

Insert the directional spool w. spring (2).

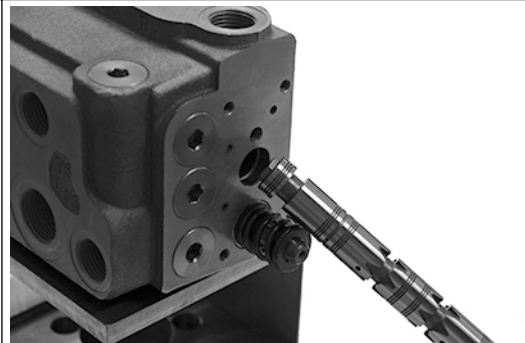



F302 233

Disassembly and assembly

Assembly of EHPS (continued)

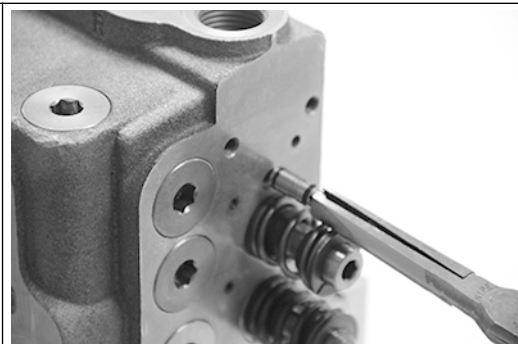
If it concerns EHPS type 1 or type 2 it has 2x shuttle valves.
 Place 2x O-rings (207) on each shuttle valves (70).
 Insert the shuttle valve (70).



Place O-rings (2x 61 and 2x 62) on the mounting surface of cover (60).
 Place the cover (60) on housing with the 4 screws (63a) using a 5 mm  Hex key.
 8 ±0.5 Nm.

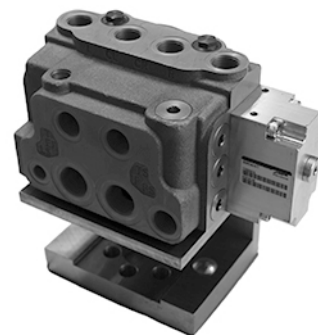
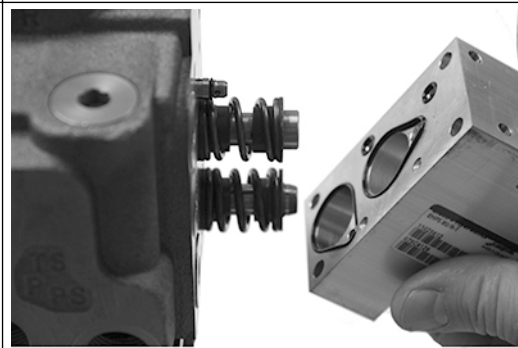

From the PVE end (type 1 and 2) or cover (66) end (type 0):
 Insert the spring (9) for priority valve.

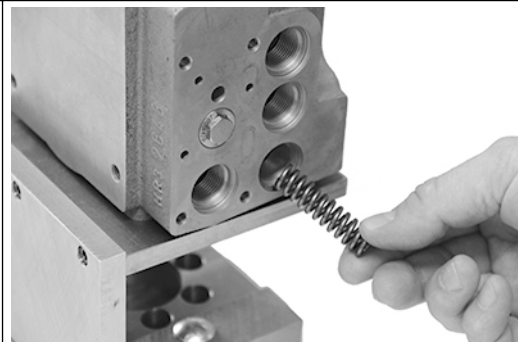



Disassembly and assembly

Assembly of EHPS (continued)

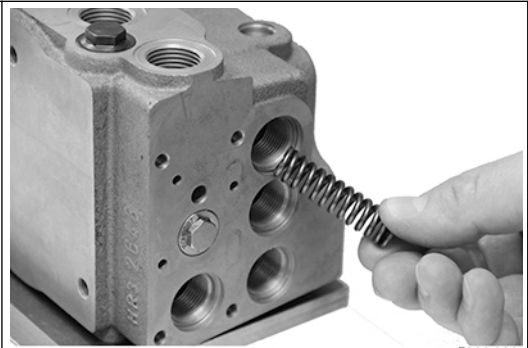
Insert the spring (5) for metering valve.



F302 238

Place O-ring (201) on to the plugs (22, the lower) (20c and 20d, the two upper short plugs).
 Screw in the plug (20c, 20d and 22) using an 8 mm 
 Hex key.
 $40 \pm 3 \text{ Nm}$

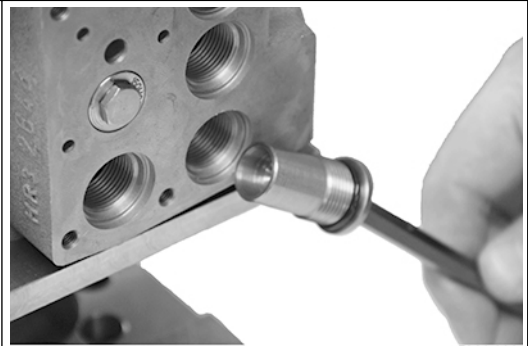

F302 239

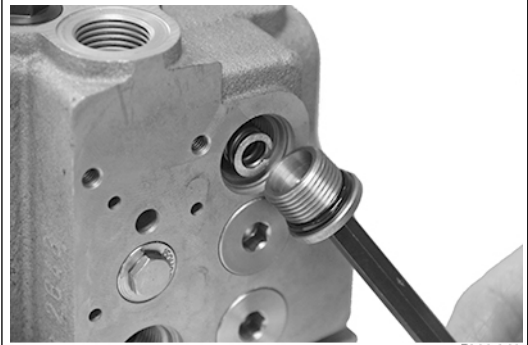

F302 240

Insert the ball (26).

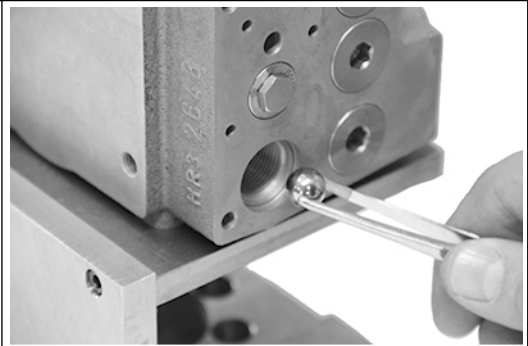

F302 241

Disassembly and assembly

Assembly of EHPS (continued)

Place O-ring (201, 202 and 203) plug (25).
 Screw in the plug (25) using an 8 mm Hex key.
 40 ±3 Nm.

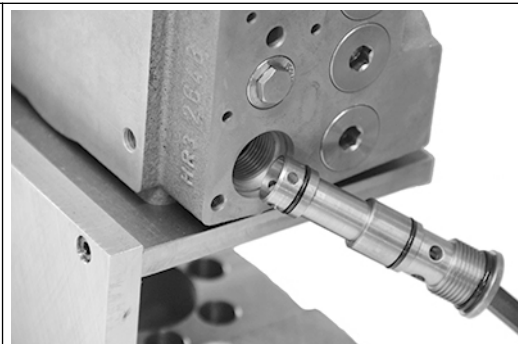

F302 242

EHPS type 0 (without PVE):
 Place O-rings (1x 62 and 3x 61) on the mounting surface of cover (66).
 Place the cover (66) on housing with the 4 screws (67) using a 5 mm Hex key.
 8 ±0.5 Nm.

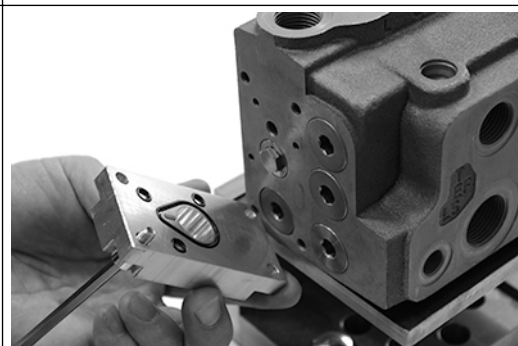

F302 243

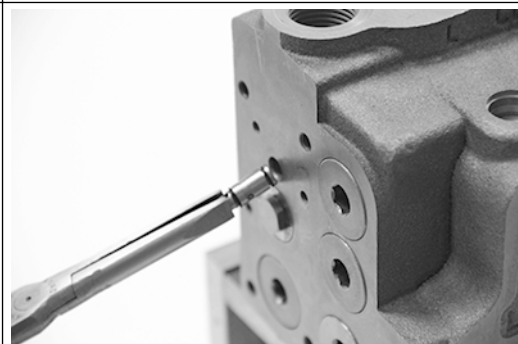

If it concerns EHPS type 1 or type 2 it has 2x shuttle valves.
 Place 2x O-rings (207) on each shuttle valves (70).
 Insert the shuttle valve (70).



F302 244

Disassembly and assembly

Assembly of EHPS (continued)

EHPS type 1 or 2 (with PVE):
 Place O-rings (3x 110, 1x 111, 1x 112 and 1x filter 114) on the mounting surface of PVE (6).
 Place the PVE (6) on housing with the 4 screws (63b) using a 5 mm  Hex key.
 8 ±0.5 Nm

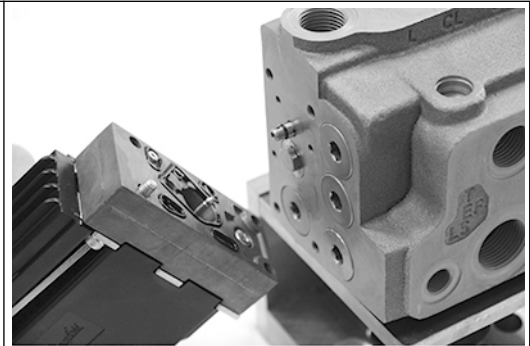

F302 245

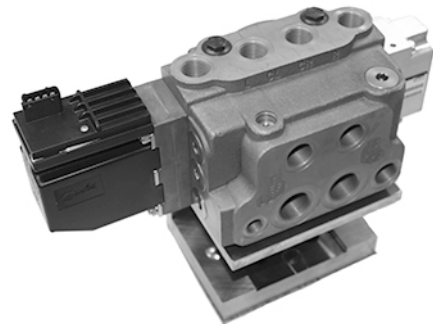

F302 246

Make test and valve setting according to [Testing of EHPS](#) on page 39.

Screw in the plastic plugs into the connection ports to keep the ports clean during storage and transportation.

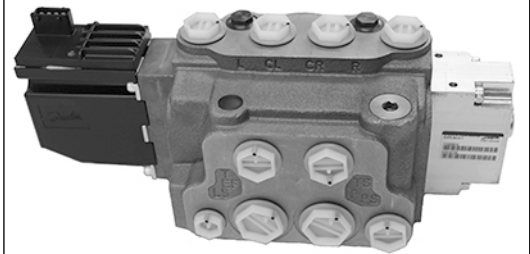



F302 247

Disassembly and assembly

Disassembly of OLS 320 and priority valve spool of EHPS

This section only describes the dismantling and assembling of parts, which differs from EHPS type 0, 1 and 2. The item numbers refers to [EHPS with flanged on OLS 320 exploded view](#) on page 9.

Disassembly of OLS 320

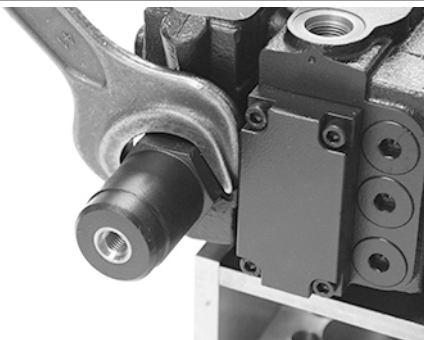
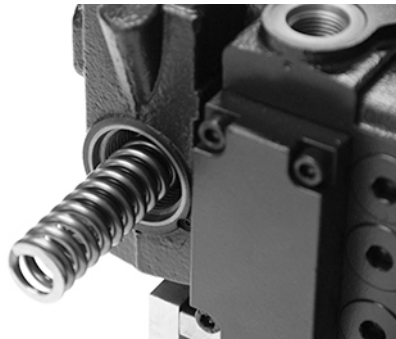
<p>Place the unit on the holding tool.</p>	 <p style="text-align: right;">F302 248</p>
<p>Screw out the LS orifice (305) using a 2 mm  Hex key, if present.</p> <p><u>Some versions of LS plug for OLS 320 has integrated LS orifice in the plug (309 as in this case), and some LS plugs are blind plugs.</u></p>	
<p>Screw out the LS plug (309) using a 41 mm  socket or ring spanner. O-ring (320) is fitted to the plug (309).</p>	 <p style="text-align: right;">F302 249</p>
<p>Remove the spring (307).</p>	 <p style="text-align: right;">F302 250</p>

Disassembly and assembly

Disassembly of OLS 320 (continued)

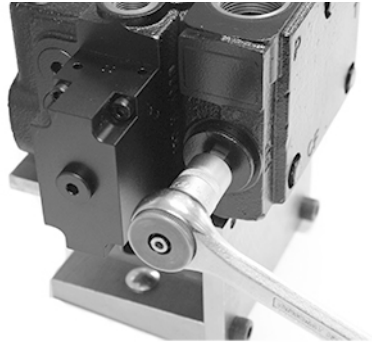
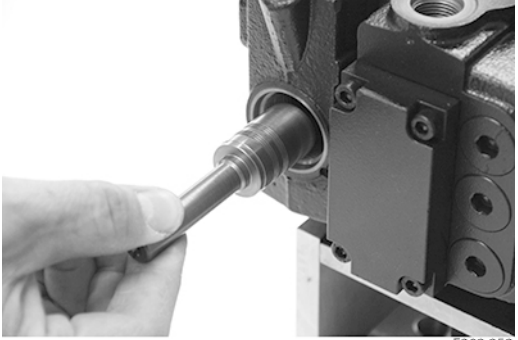
<p>Screw out the LS plug (310) using a 14 mm  Hex key. O-ring (320) is fitted to the plug (310).</p>	 <p style="text-align: right;">F302 251</p>
<p>Remove the priority valve spool (304). Orifice, PP (306) is screwed into spool (304).</p>	 <p style="text-align: right;">F302 252</p>

Disassembly and assembly

Disassembly of OLS 320 (continued)

Remove the OLS 320 housing (301) from the EHPS by unscrewing the 3 screws (322) using a 13 mm  socket or ring spanner. 3 washers (323) are fitted to the screws (322). 2 O-rings (321) are fitted to the EHPS-housing (1).

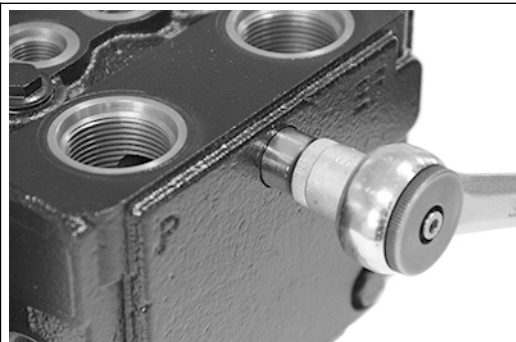

F302 253

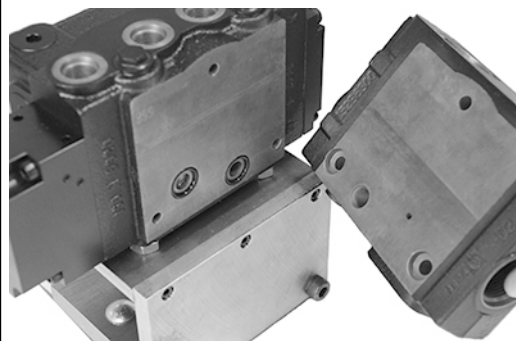

F302 254

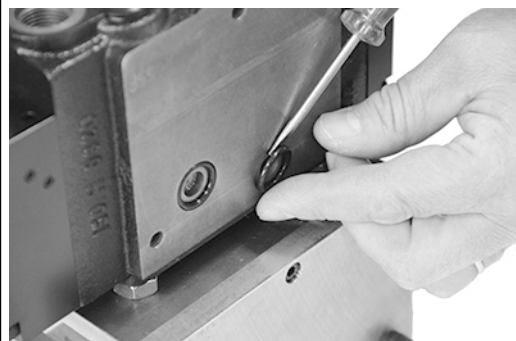



F302 255

Now the OLS 320 is completely dismantled

Disassembly and assembly

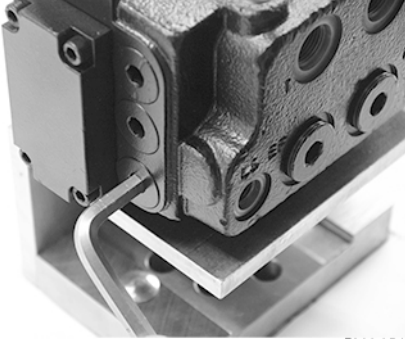
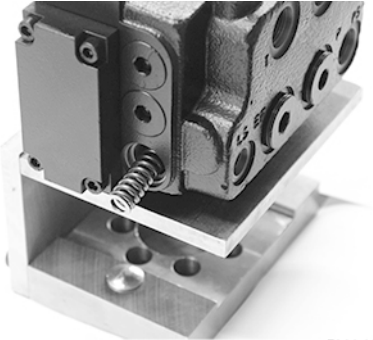
Disassembly of EHPS

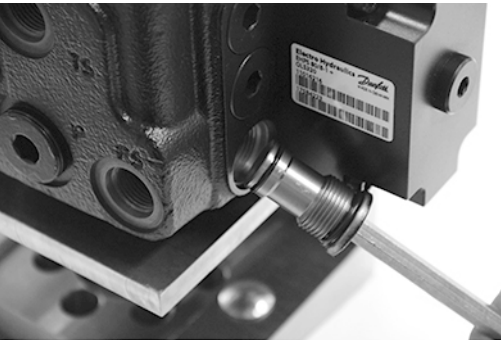
<p>Screw out the plug (22) using an 8 mm  Hex key. O-ring (201) is fitted to the plug.</p>	 <p>F302 256</p>
<p>Remove the spring (9).</p>	 <p>F302 257</p>
<p>Screw out the plug (23) using an 8 mm  Hex key. O-rings (201 and 202) are fitted to the plug (23).</p>	 <p>F302 258</p>

Disassembly and assembly

Disassembly of EHPS (continued)

Remove the priority valve spool (7).
 Orifice, dynamic (8), orifice, PP (10) and are screwed into spool (7).
 Filter (12) is fitted into the spool (7).

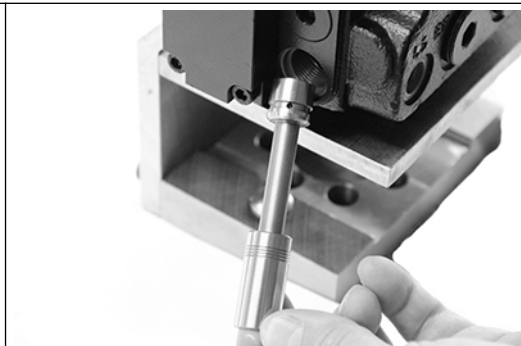

F302 259



F302 260

All other EHPS parts are the same for EHPS "stand alone" and for EHPS for OLS 320.

Cleaning:

Clean all parts carefully in Shellsol K or similar cleaner fluid.

Inspection and replacement

Replace all seals and washers.

Check all parts carefully and make any replacements as is necessary.

Assembly of OLS 320 and priority valve spool of EHPS

Assembly of OLS 320 and priority valve spool of EHPS

Place the EHPS housing on the holding tool.

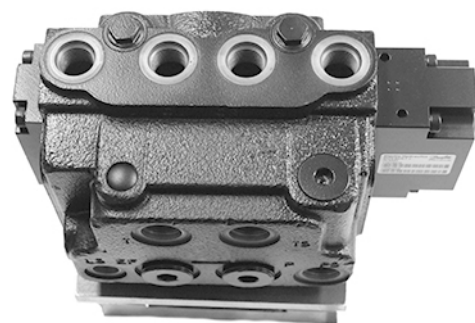

F302 261

Assemble all parts for EHPS, see [Assembly of EHPS](#) on page 23.

Disassembly and assembly

OLS parts for EHPS for OLS 320:

From the end cover (60) end:
Place O-rings (201 and 202) on the plug (23, the lower plug).
Screw in the plug (23) using an 8 mm Hex key.
40 ±3 Nm.

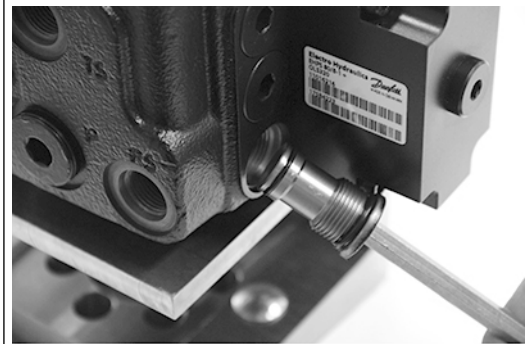

F302 258

Assemble priority valve spool (7) with:
The dynamic orifice (8) using a 3 mm Hex key, 3.5 ±0.5 Nm.
The filter (12) to be inserted.
The PP orifice (10) using a 4 mm Hex key, 3.5 ±0.5 Nm.
From the PVE end (type 1 and 2) or cover (66) end (type 0):
Insert the priority valve spool (7) with the spring bore pointing outwards.

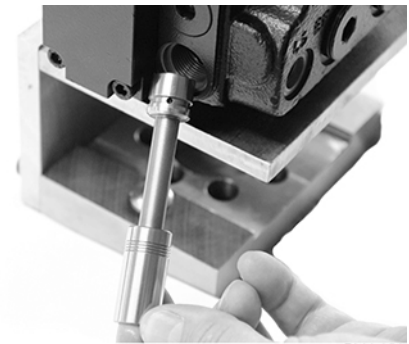

F302 259

Insert the spring (9) for priority valve.

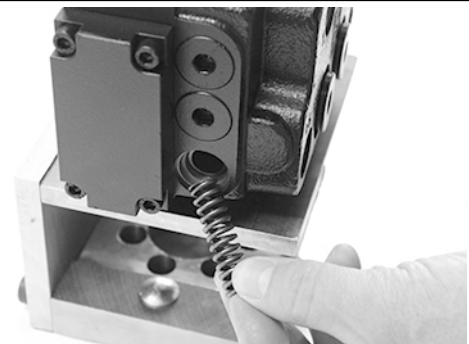

F302 262

Place O-ring (201) on to the plugs (22, the lower).
Screw in the plug (22) using an 8 mm Hex key.
 40 ±3 Nm

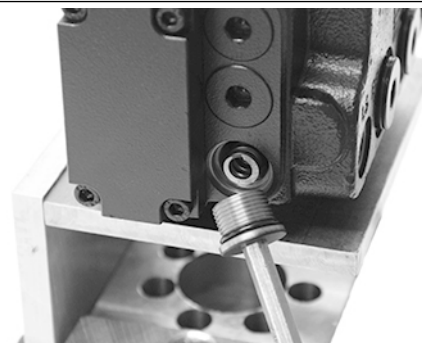



F302 263

Disassembly and assembly

OLS parts for EHPS for OLS 320: (continued)

Flange the OLS 320 housing (301) on the EHPS housing (1):
 Insert the two O-rings (321) in the EHPS housing (1) indicated in circle. Fit the three screws (322) with washers (323) and insert them.

Use a 13 mm  top wrench,  28 ±2 Nm.

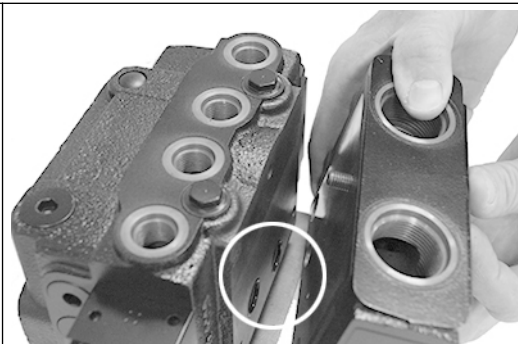



F302 264



F302 265

Place O-ring (320) on the plug (310).

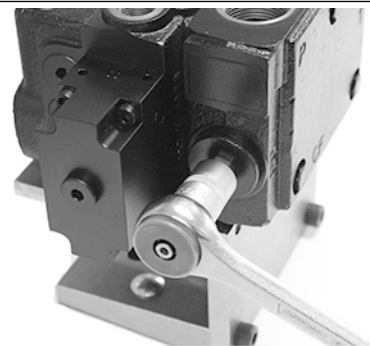

Screw in the plug (320) using a 14 mm  Hex key.

 50 ±5 Nm



F302 251

Assemble priority valve spool (304) with:

The PP orifice (306) using a 3 mm  Hex key,  3,5 ±0.5 Nm.



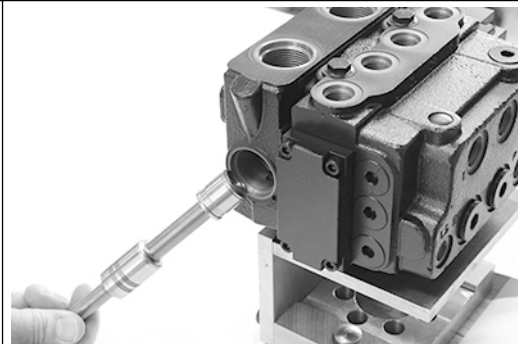

Insert the priority valve spool (304) with the spring guide pointing outwards.

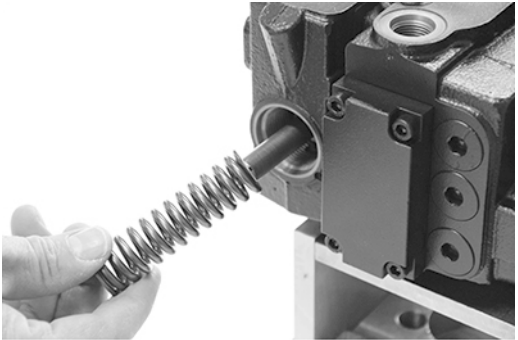

F302 266

Disassembly and assembly

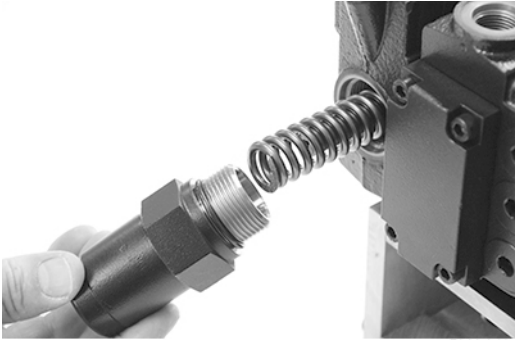
OLS parts for EHPS for OLS 320: (continued)

<p>Insert the spring (307) for priority valve.</p>	 <p style="text-align: right;">F302 267</p>
<p>Place O-ring (320) on the plug (309). Screw in the plug (320) using a 41 mm  socket spanner,  50 ±5 Nm</p>	 <p style="text-align: right;">F302 268</p>
<p>If present: Screw in the LS orifice (305) using a 2 mm  Hex key, 1 ±0.1 Nm.</p> <p><u>Some versions of LS plug for OLS 320 integrated LS orifice in the plug (305, as in this case), and some LS plugs are blind plugs.</u></p>	
<p>To make test and valve setting, see Testing on page 39.</p> <p>Screw in the plastic plugs into the connection ports to keep the ports clean during storage and transportation.</p>	 <p style="text-align: right;">F302 269</p>

Testing

Testing of EHPS

This section describes minimum tests needed, when the EHPS steering valve has been disassembled and reassembled.

EHPS type 1 with PVES:

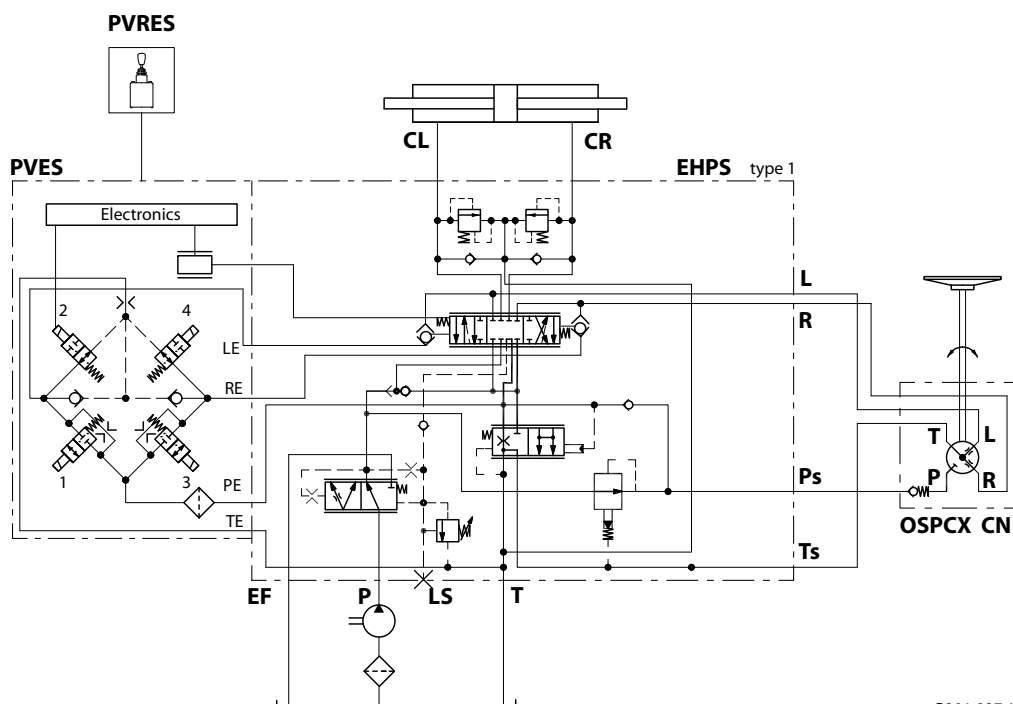

P301 827.10

Set up for testing the EHPS

Use universal hydraulic work bench with pump capacity:

- 40 l/min and up to 250 bar pressure for relief valve setting and steering test

The hydraulic oil must be with a viscosity of 21 cSt. at 50 ° and with max. degree of contamination according to ISO 4406: 21 / 19 / 16.

1. Connect double rod cylinder to CL and CR ports of EHPS.
2. Connect pilot steering unit OSPCX CN to EHPS: L to L, R to R, P to Ps, T to Ts.
3. Connect T and EF port of EHPS to tank of pump station.
4. With fixed gear pump in pump station: Block LS of EHPS with steel plug. With LS pump in pump station: connect LS of EHPS to LS of pump. Connect P to pump outlet.
5. Connect pressure gages to all ports of EHPS.
6. Connect steering column and steering wheel to the input shaft of the OSPCX steering unit.
7. For EHPS with PVES, PVED CC, PVED CL, after steering wheel test (test with pilot steering unit, type OSPCX CN): Connect voltage supply and signal input for the PVE.

T pressure should not exceed ~5 bar. Max. allowed T pressure is 25 bar.

Pump supply circuit must be adjusted not to exceed 250 bar P-T.

Steering test using pilot steering unit type OSPCX CN

During the testing no motor effect, disturbing vibrations, noise, sticking or other irregularities must occur.

1. Start the pump, the pump flow is adjusted to approx. 40 l/min and pump pressure control must be set to app. 70 bar.

Testing

2. Let the supplied oil flow through the EHPS for a few minutes. At the same time the steering wheel is to be rotated a few times in both directions to bleed of air from the unit and the system.
3. Operate the steering wheel by approx. 10 rpm in a smooth manner from end stroke to end stroke of the steering cylinder for at least 5 cycles. Make sure pressure P-T, 70 bar can be achieved, when steering against end stroke. If this is not possible, the adjusting screw of the pilot relief valve (item 94 of exploded view) must be turned clockwise until P-T, 70 bar is achievable.
4. Verify, that steering cylinder does not move, when steering wheel is untouched.

The number of turns i on steering wheel must match this calculation: $i \approx V/V_{vs}$ where:

- V is stroke volume of steering cylinder, ccm
- V_{vs} = EHPS steering system displacement, ccm/rev.

V , stroke volume if cylinder in test rig: 1600 ccm

V_{vs} , steering system displacement with EHPS 40/5 and OSPCX 50 CN: 400 ccm/rev

>

$i \approx 1600/400$ 4 turns lock to lock

This calculation will only match, when pump flow is sufficient for the actual steering speed. Pump flow must be minimum sum of cylinder flow (CQ, flow metered to steering cylinder) and pilot flow (PQ, flow from pilot steering unit).

Pilot relief valve for EHPS

The pump flow is adjusted to approx. 40 l/min and pump pressure to max 250 bar.

The steering wheel is actuated until the steering cylinder reaches one of its end strokes and the steering wheel is actuated in this cylinder position with steering torque 20 ± 5 Nm.

The pilot relief valve (item 94 of exploded view) is set according to specification: Max. steering pressure (P-T), bar, for the code in question.

The setting pressure is the pressure on the P-port minus the T-port of EHPS.

Neutral positioning test, OSP part for EHPS

After adjusting the pilot relief valve, the steering wheel must be able to go to neutral position by itself no later than ~1 second after the activation of the steering wheel has been stopped.

The steering unit and EHPS is proper in neutral position when the pressure drop (P-T of EHPS) is no higher than 30 bar at pump flow 40 l/min, and there must be no movement of the steering cylinder.

Steering and neutral positioning test, EH part with EHPS

For EHPS with PVES, PVED CC, PVED CL: Apply battery power and input signal to the PVE: observe that the steering cylinder is moving according to direction of input signal for PVE. Observe that max steering pressure (P-T) from above setting can be reach, when steering cylinder is moved to full end stroke by the PVE. Apply neutral position signal for PVE, observe that cylinder movement stops and that pressure P-T drops to max. 30 bar at pump flow 40 l/min.

Manual steering with EHPS

Without pressure on P and T ports, the OSPCX and EHPS must be able to steer in a smooth manner to the right and to the left observed by the cylinder movement. The number of turns on the steering wheel for moving the steering cylinder from lock to lock, must increase in comparison to do this test with normal supply.

Without pump supply the number of turns must match cylinder volume/displacement of OSPCX.

Example: Cylinder volume: 1600 ccm, and OSPCX 50 CN > Number of turns must be $1600/50 \approx 32$ turns.

Testing

Testing of EHPS with OLS 320

Testing of EHPS with OLS 320

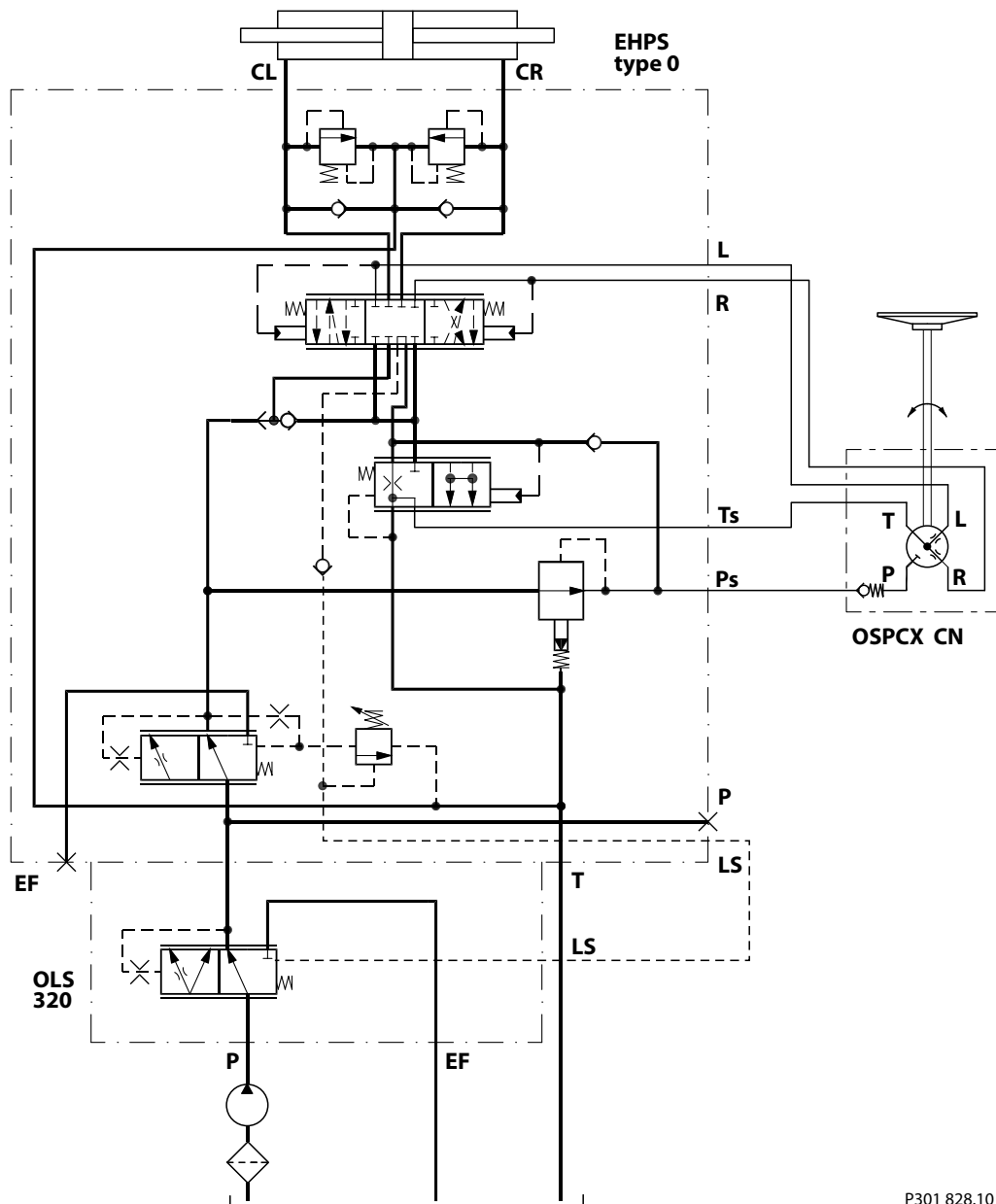

P301 828.10

Set up for testing the EHPS with OLS 320

Setup and testing for EHPS w. OLS 320 will be the same as for EHPS "stand alone" except:

- P from pump station is connected to P of OLS 320
- EF of OLS 320 to T of pump station
- LS of OLS 320 to LS of EHPS.

Products we offer:

- Bent Axis Motors
- Closed Circuit Axial Piston Pumps and Motors
- Displays
- Electrohydraulic Power Steering
- Electrohydraulics
- Hydraulic Power Steering
- Integrated Systems
- Joysticks and Control Handles
- Microcontrollers and Software
- Open Circuit Axial Piston Pumps
- Orbital Motors
- PLUS+1® GUIDE
- Proportional Valves
- Sensors
- Steering
- Transit Mixer Drives

Danfoss Power Solutions is a global manufacturer and supplier of high-quality hydraulic and electronic components. We specialize in providing state-of-the-art technology and solutions that excel in the harsh operating conditions of the mobile off-highway market. Building on our extensive applications expertise, we work closely with our customers to ensure exceptional performance for a broad range of off-highway vehicles.

We help OEMs around the world speed up system development, reduce costs and bring vehicles to market faster.

Danfoss – Your Strongest Partner in Mobile Hydraulics.

Go to www.powersolutions.danfoss.com for further product information.

Wherever off-highway vehicles are at work, so is Danfoss. We offer expert worldwide support for our customers, ensuring the best possible solutions for outstanding performance. And with an extensive network of Global Service Partners, we also provide comprehensive global service for all of our components.

Please contact the Danfoss Power Solution representative nearest you.

Comatrol

www.comatrol.com

Schwarzmueller-Inverter

www.schwarzmueller-inverter.com

Turolla

www.turollaocg.com

Hydro-Gear

www.hydro-gear.com

Daikin-Sauer-Danfoss

www.daikin-sauer-danfoss.com

Local address:

Danfoss Power Solutions (US) Company
2800 East 13th Street
Ames, IA 50010, USA
Phone: +1 515 239 6000

Danfoss Power Solutions GmbH & Co. OHG
Krokamp 35
D-24539 Neumünster, Germany
Phone: +49 4321 871 0

Danfoss Power Solutions ApS
Nordborgvej 81
DK-6430 Nordborg, Denmark
Phone: +45 7488 2222

Danfoss Power Solutions Trading (Shanghai) Co., Ltd.
Building #22, No. 1000 Jin Hai Rd
Jin Qiao, Pudong New District
Shanghai, China 201206
Phone: +86 21 3418 5200

Danfoss can accept no responsibility for possible errors in catalogues, brochures and other printed material. Danfoss reserves the right to alter its products without notice. This also applies to products already on order provided that such alterations can be made without changes being necessary in specifications already agreed. All trademarks in this material are property of the respective companies. Danfoss and the Danfoss logotype are trademarks of Danfoss A/S. All rights reserved.