

Data Sheet

Open Circuit Piston Motors

Reverse Displacement Motor (RDM)



For more than 40 years, Danfoss has been developing state-of-the-art components and systems for mobile machinery used in off-highway operations around the world. We have become a preferred supplier by offering the best of what really matters: the hardware inside your vehicle application.

The Reverse Displacement Motor (RDM) is designed for use in mobile open circuit applications. It offers reverse functionality without external valves, and provides system robustness with available anti-cavitation and shock valves. The RDM uses the existing and proven technology of the Danfoss L/K motor. These motors have been optimized with regard to options, life, package size and installed cost.

The RDM is a two-position reversing motor, with smooth, shift-on-the-go capability. The integrated proportional shifting valve uses system pressure. It allows reversing functionality without external valves and external pressure supply.



Features

Designed for Durability and Flexibility

- Especially designed for open circuit applications with a need for reverse functionality
- Five displacements allow the optimum selection of a hydraulic motor to fit your application
- Reliability - uses existing and proven technology of Danfoss L&K motors

Installation and Packaging benefits

- Short and compact
- High efficiency - nine piston rotating groups with an 18 degree maximum angle
- Uses system pressure for shifting – no external pressure supply needed
- Integrated shifting valve enables reversing – no external valves needed - less hoses - less losses - simple and clean installation
- 12 V_{DC} and 24 V_{DC} valves

Wide Range of Options

- **Fail Safe:** Without control signal, the motor is biased to maximum forward speed
- Damped shifting from reverse to forward
- Shaft options with dust seal protector
- Integrated system protection - anti-cavitation and shock valve
- High capacity bearings to withstand axial fan forces
- Complimentary to Danfoss Series 45 open circuit pumps with electronic proportional control
- PLUS+1[®] micro controller with fan drive software available
- This motor has the capability to be held at or near neutral for potential added system power savings or faster heating of the engine at start-up
- Variety of porting options allow for easier system configurations system configurations

- Metric O-Ring boss
- SAE O-Ring boss
- Split flange
- A speed sensor is available

Applications

- Fan Drives with reverse functionality
- Conveyers
- Etc.

Comprehensive technical literature online
at powersolutions.danfoss.com

Reverse Displacement Motor (RDM)

Technical Specifications

Parameter		Unit	LM25	LM30	LM35	KM38	KM45
Displacement (maximum)		cm ³ [in ³]	25 [1.50]	30 [1.83]	35 [2.14]	38 [2.32]	45 [2.75]
Weight		kg [lb]	17.5 [38.6]				
Theoretical torque		N·m/bar [lbf·in/1000 psi]	0.40 [244]	0.48 [293]	0.56 [347]	0.60 [366]	0.72 [439]
Output speed	Rated	min ⁻¹ (rpm)	3400	3500	3600	3600	3500
	Max.		3950	4150	4300	4000	3900
System pressure ⁽¹⁾	Max.	bar [psi]	350 [5075]	350 [5075]	325 [4715]	350 [5075]	350 [5075]
Case pressure	Rated	bar [psi]	0.5 [7] above outlet pressure, 2 [29] absolute pressure				
	Max.		2 [29] above outlet pressure, 6 [87] absolute pressure				
Voltage		V _{DC}	12, 24				
Current	12 V _{DC}	mA	1500				
	24 V _{DC}		750				
Connector		-	DEUTSCH connector DT04-2P				

⁽¹⁾ Refer to L and K Frame Variable Motors Technical Information 520L0627 for pressure definitions

Fan Drive Circuit

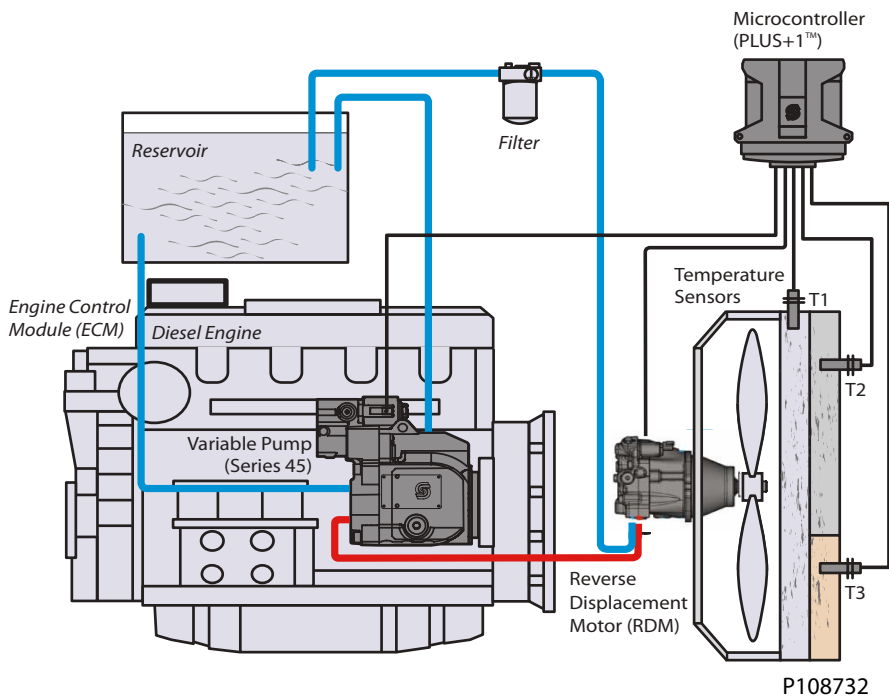

Dimensions

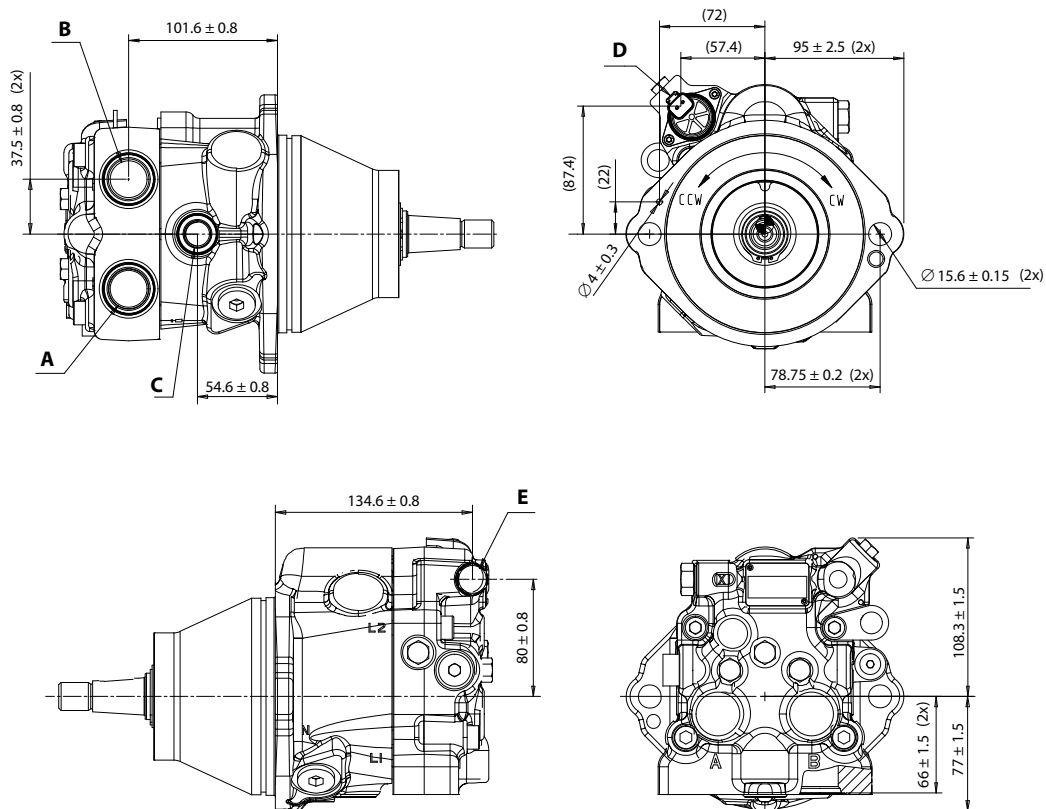

P109030

	Description	Metric	Inch
A/B	System port	ISO 6941-1, M 27x2	ISO 11926-1, 1-1/16-12
C	Case Drain	ISO 6941-1, M 18x1.5	ISO 11926-1, 3/4-16
D	Solenoid connector	DEUTSCH DT04-2P	
E	Control gauge port	ISO 6941-1, M 14x1.5	ISO 11926-1, 9/16-18

ENGINEERING
TOMORROW



**Danfoss
Power Solutions (US) Company**
2800 East 13th Street
Ames, IA 50010, USA
Phone: +1 515 239 6000

**Danfoss
Power Solutions GmbH & Co. OHG**
Krokamp 35
D-24539 Neumünster, Germany
Phone: +49 4321 871 0

**Danfoss
Power Solutions ApS**
Nordborgvej 81
DK-6430 Nordborg, Denmark
Phone: +45 7488 2222

**Danfoss
Power Solutions Trading
(Shanghai) Co., Ltd.**
Building #22, No. 1000 Jin Hai Rd
Jin Qiao, Pudong New District
Shanghai, China 201206
Phone: +86 21 3418 5200

Danfoss can accept no responsibility for possible errors in catalogues, brochures and other printed material. Danfoss reserves the right to alter its products without notice. This also applies to products already on order provided that such alterations can be made without changes being necessary in specifications already agreed.
All trademarks in this material are property of the respective companies. Danfoss and the Danfoss logotype are trademarks of Danfoss A/S. All rights reserved.
