



ENGINEERING
TOMORROW

Danfoss

Case story | NovoCon®

Outstanding HVAC flexibility after high-end office building renovation

For many office buildings that were constructed in the 1970s and 80s a critical decision needs to be made about their future existence. The option of a shell & core renovation is increasing popular. Except for the main structure, an entirely new office including state of the art HVAC system can be established.

hbc.danfoss.com

Optimized heating and cooling comfort for office workers

An innovative and compact HVAC hydronic balancing and control solution provides both office workers and technicians a flexible HVAC solution. Read how an old office building was renovated and equipped with a state of the art control solution for its heating and cooling system.

The project

In Düsseldorf, Germany, a commercial property built in the 1970s has been extensively renovated. An important requirement was to obtain certification from the DGNB (German Sustainable Building Council). After the demolition of the ten-story existing building, only the support structure was retained. Now, after completion of the renovation, the inside of the building contains flexible spaces that can be used as single, group or open space offices. Most of the office spaces are rented out to software company Oracle and die developer Projektentwicklung GmbH, also the contractor of the renovation. Both tenant's value appealing design and the use of modern technology.

The challenge

ENGIE Germany is responsible for the entire HVAC system. This includes the planning and installation of water, electricity, cooling and heating equipment in the Forty-Four project. The parameters for efficiency, flexibility and sustainability were generally very high in the specifications for the planners.

Dipl.-Ing. (FH) Andreas Velten is a project manager in the Building Services division of ENGIE. In the Forty-Four project, he is responsible for the entire Building Management System (BMS) – for the planning and the smooth implementation of the installation. In coordination with colleagues from other specialty areas, he also selects the required products.

The indoor climate presented a challenge for the BMS designers. Because the building was completely rebuilt during the revitalization, the new tenants would at first have office space available without any separation walls. The offices would be individually designed later, using flexible partition walls. With no knowledge of the later use of the spaces, the BMS system had to be planned and installed with the greatest flexibility. "So, we had to do our planning with the idea in mind that every imaginable scenario could be implemented later," Andreas explains.



Danfoss NovoCon®, mounted on AB-QM, controls both the flow through the PICV valve and the position of the CO⁶ actuator mounted on the heating/cooling 6-way ChangeOver valve.



In terms of energy efficiency, high flexibility in the allocation of new office spaces, and not least because of the convenient, time-saving and error-preventive installation technology, the NovoCon® concept is overall more cost-effective than conventional solutions.

Andreas Velten,
ENGIE BMS project manager
in the Forty-Four project

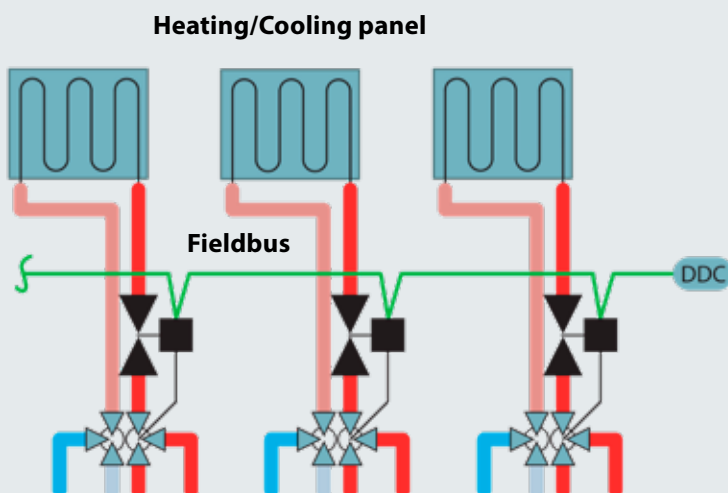

The NovoCon® concept in the application with heating/cooling panels in a 4-pipe change-over system. The integration of Flow and return temperature sensors, dew point sensors, window contacts, room temperature, etc., can be carried out at any time.

The Solution

Whether we are talking about the heating load or the cooling load, hydronic balancing (i.e. achieving design volume flows in the respective media cycle) always plays a key role in terms of total system efficiency and costs.

Hydronic balancing used to be a nightmare for many installers due to complex calculations and prolonged assembly work. Nowadays it is easy to handle with Danfoss pressure independent valve technology. And it is also more precise than ever, as shown in the Forty-Four project. To balance and control both heating and cooling in the building, a compact product combination was selected. It consists of the NovoCon® ChangeOver⁶ actuator mounted on a 6-way ChangeOver valve which allows either heating or cooling water to flow through. To control the flows, the AB-QM control valve was equipped with the NovoCon® digital actuator, allowing remote adjustment of the design flow for heating and cooling operation.

In the past, hydronic balancing and control was not part of building automation. This is now changing with the NovoCon® digital actuator, which enables a field bus connection of the heating and cooling systems to the BMS so that information can be collected from each individual actuator. Installed on the pressure independent AB-QM balancing and control valve, the adjustment of the settings and control are carried out remotely via NovoCon®, including commissioning and fine-tuning.

BACnet remote control functions, such as commissioning, flow display and flushing, are available bi-directionally, as are status messages and alarms. By logging the data, facility management can identify potentials for improvement in the energy settings and consumption.

The benefits

“With conventional construction and BMS design, we would for example have to install new cables or re-route them when setting up a new office space. But with the BACnet infrastructure, we can easily structure these types of things using the central control technology. So, for example, we can adjust some of the installed NovoCon® actuators to together control this new established office space in the building” explains Andreas Velten. And he adds: “In the Forty-Four project we have installed 457 NovoCon® and AB-QM with heating <> cooling change-over system solutions. They provide individual room temperature control for the respective ceiling panels. Because of the open BACnet communication structure, it is possible to optimize the supply network in terms of efficiency and present any parameters transparently to the tenant.”

The NovoCon® concept is also impressively smart in terms of assembly/commissioning, making time-consuming routine work a thing of the past. Andreas Velten adds: “The NovoCon® concept has proven to be a practical “plug & play” technology for us in this project.” This is also due to the fact that pre-assembled cables are available in different lengths. These facilitate quick, error-free installation of the systems. Commissioning also proved to be extremely easy and saved a lot of time. For example, in a single evening we were able to put four floors into operation and conducted a 1:1 system performance test in less than four hours.” With conventional technology, Andreas Velten estimates that the time needed for this would be three to four days.



Revitalization of a commercial property from the 1970s: In the Forty-Four project in Düsseldorf, the parameters for efficiency, flexibility and sustainability were very high in the specifications for the planners.

Goal: Certification from the DGNB (German Sustainable Building Council).



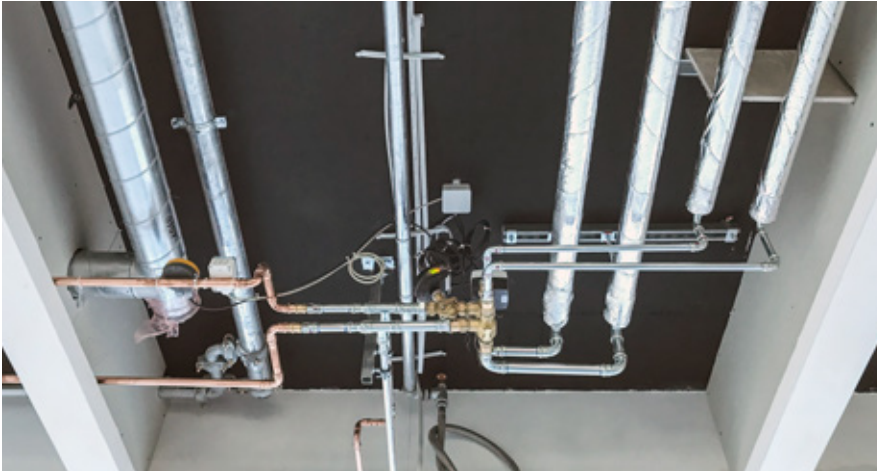

In the Forty-Four project, 457 sets of NovoCon® and AB-QM based change-over system solutions were installed. The open BACnet communication structure significantly reduces the number and length of cables that need to be used.

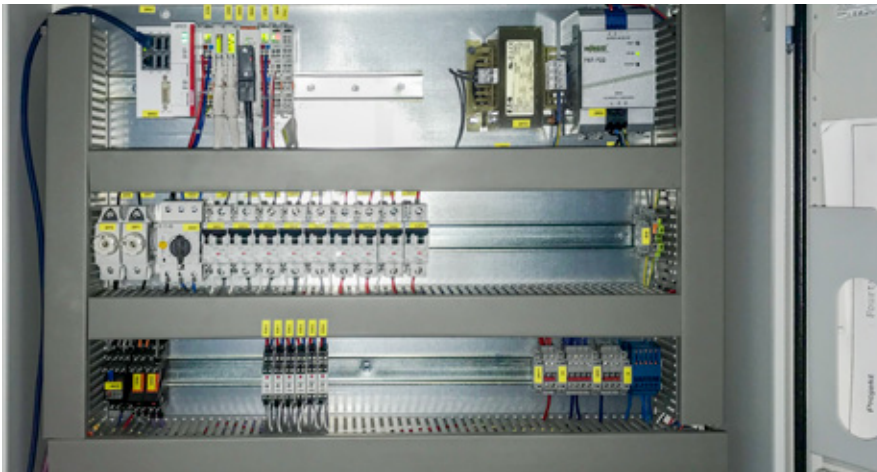

Because of the NovoCon® solution, ENGIE managed with less BMS controllers and components in the DDC connection boxes as installed on all the 10 floors of the building.

About ENGIE

ENGIE Germany is one of Germany's leading specialists in technology, energy and service. It offers technical building services systems, plant and process technology, facility management, energy management, energy procurement, renewable energy and industrial cooling technology.

ENGIE Germany has 30 branches throughout Germany and generated sales of around 1.8 billion euros in 2016, with 3,000 employees. The ENGIE Group, which is listed on the stock exchange, is a global leader in electricity, natural gas and liquefied natural gas (LNG) and energy services, generating sales of around 66.6 billion euros in 2015, with 153,000 employees.

System overview

- 457 ChangeOver⁶ valves (DN15/20)
- 457 NovoCon® ChangeOver⁶ actuators
- 457 AB-QM PICV valves (DN15/20)
- 457 NovoCon® digital actuators
- Field bus: BACnet MS/TP



Danfoss is engineering HVAC 4.0 for smart buildings.
Find out more on hvac40.danfoss.com

Danfoss A/S

Heating Segment • heating.danfoss.com • +45 7488 2222 • E-Mail: heating@danfoss.com

Danfoss can accept no responsibility for possible errors in catalogues, brochures and other printed material. Danfoss reserves the right to alter its products without notice. This also applies to products already on order provided that such alterations can be made without subsequential changes being necessary in specifications already agreed. All trademarks in this material are property of the respective companies. Danfoss and all Danfoss logotypes are trademarks of Danfoss A/S. All rights reserved.