

Mobile Hydraulic | CAN DST P92C / T92C

Now you **CAN** reduce downtime and total cost of ownership with our **new transmitters**

New Danfoss transmitters, DST P92C (pressure) and DST T92C (temperature) are now available with CAN interface. The two CAN transmitters offer professionals reliable, robust, and cost-effective solutions for mobile hydraulic machinery used in demanding applications.

CANopen[®]

and SAE J1939
compliant with
E1 type approval



With Danfoss you CAN too

To help professionals keep up with the latest CAN components, Danfoss has launched two new CAN transmitters, DST P92C (pressure) and DST T92C (temperature) for mobile hydraulic applications.

The modern fieldbus technology reduces wiring costs and provides new opportunities in condition monitoring and predictive maintenance. Additionally, the standardized CAN communication allows compatibility with devices and systems from different manufacturers.



Reduce installation costs

Simplified wiring and less I/O modules

CAN is an extremely robust and cost-effective way to develop and control complex machines thanks to its simplified wiring and a reduced number of I/O modules. The simplified system design eliminates the need for point to point wiring and eases the integration of components in the overall system, resulting in a more cost-effective design process and accelerated time to market.

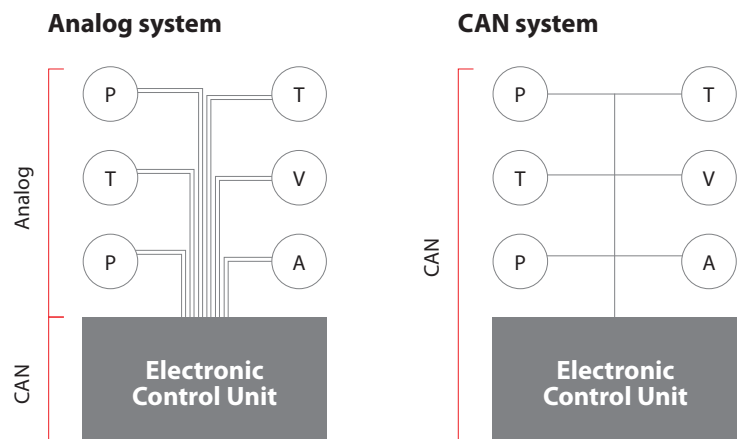



Improve operational efficiency

High reliability and uptime

With CAN-enabled components, operators can easily monitor and diagnose machine conditions in real-time. During operation, the real-time diagnostics ensures high reliability and uptime and allows predictive maintenance to prevent unplanned stops and reduce downtime on equipment significantly.

The logging and recording capabilities of CAN components tie well in with advanced telematics solutions supporting remote upgrades and service, efficiency and fleet management, and operator safety.

Applications in focus

DST P92C and T92C pressure and temperature transmitters can be used in almost all mobile hydraulic applications. However, with their simplified system design, CAN-enabled components offer the most value in high-end machinery where they can significantly reduce the number of controls and wiring.

- Concrete pump
- Rock drilling rig
- Autonomous tractor
- Citrus harvester
- Reach stacker
- Mobile crane
- Forestry harvester
- Pistenbully



DST P92C & T92C CANopen® pressure and temperature transmitters

The new DST and SAE J1939 transmitters are designed with excellent EMC properties making them extremely robust and highly resistant to chock and vibrations.

To ensure optimum customization, the CAN transmitters can be used with almost any media due to the stainless-steel casing and fully welded enclosure.

- ✓ Reduced and simplified wiring
- ✓ Direct communication with the Electronic Control Unit without using I/O modules
- ✓ Improved overall system performance

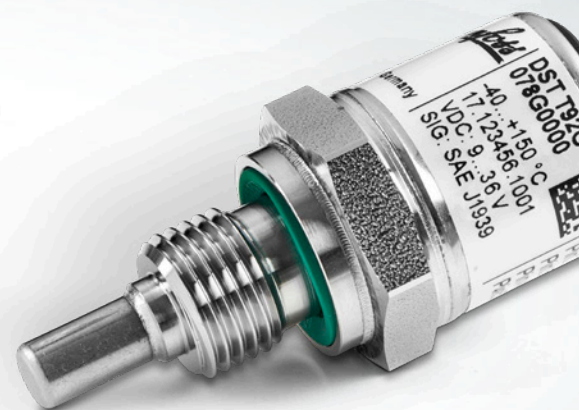
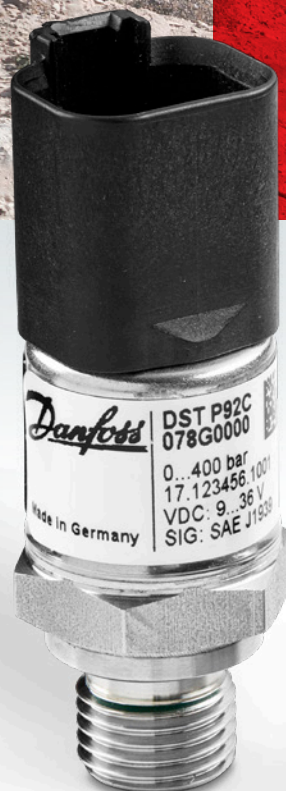

CANopen®

SAE J1939

DST P92C & T92C

technical specification

CANopen® Pressure Sensor DST P92C	
Pressure range	0 - 1200 bar
Operating temperature	-40 ... +125°C
Outputs	CANopen® SAE J1939
Electrical connections	M12 x 1 EN60947-5-2 Bayonet DIN 72585 Deutsch DT04-4P
IP	IP67
Over all accuracy	<=0.5 %FS (0 ... +105°C) <=1.5 %FS (-40 ... +0°C) <=1.5 %FS (105 - 125°C)
Pressure connections	SAE 4 - 7/16-20 UNF SAE 6 - 9/16-18 UNF G 1/4-DIN 3852-E
Certifications	E1, CE, UL
Wetted material	Stainless steel

CANopen® Temperature Sensor DST T92C	
Reaction time	$t_{0.5} = 4$ sec, water 0.2 m/s
Operating temperature	-40 ... +150°C
Outputs	CANopen® SAE J1939
Electrical connections	M12 x 1 EN60947-5-2 Bayonet DIN 72585 Deutsch DT04-4P
IP	IP67
Over all accuracy	0.6 %FS (-40 ... +150°C) 0.4 %FS (-40 ... +85°C)
Process connection	G 1/4" DIN 3852-E
Certifications	E1, CE
Wetted material	Stainless steel

A wide product portfolio

for a wide range of applications

When cooperating with Danfoss Sensing Solutions, you gain access to the entire Danfoss pool of market-leading technology.

We have the solutions and application know-how to help you achieve functional safety compliance more easily, reduce total installed costs, and accelerate time to market.

To learn more about our comprehensive product portfolio and solutions visit hydraulicsensors.danfoss.com



Danfoss A/S, Sensing Solutions

DK-6430 Nordborg · Denmark : sensors@danfoss.com · www.sensors.danfoss.com

Danfoss can accept no responsibility for possible errors in catalogues, brochures and other printed material. Danfoss reserves the right to alter its products without notice. This also applies to products already on order provided that such alterations can be made without subsequential changes being necessary in specifications already agreed. All trademarks in this material are property of the respective companies. Danfoss and the Danfoss logotype are trademarks of Danfoss A/S. All rights reserved.