

Danfoss Industrial Refrigeration | Intelligent Purger System

# Straightforward installation and continuous **efficiency** and safety

At Danfoss, we are extending our wide portfolio for industrial refrigeration to include the Intelligent Air Purger System, also known as Danfoss IPS.

With its compact design, easy installation and automatic purging functionality, the new Danfoss IPS helps improve the operational safety, efficiency and cost-effectiveness of industrial refrigeration systems.



1

connection for  
simple installation

# Advanced air purger solution for industrial refrigeration

The new Danfoss Intelligent Purger System (IPS) is an automatic, self-contained operating unit that helps remove non-condensable gases in a safe and energy-efficient way. This helps maintain an optimum refrigeration capacity and system efficiency, allowing professionals to achieve maximum system performance.

## Zoom in on the Danfoss IPS 8

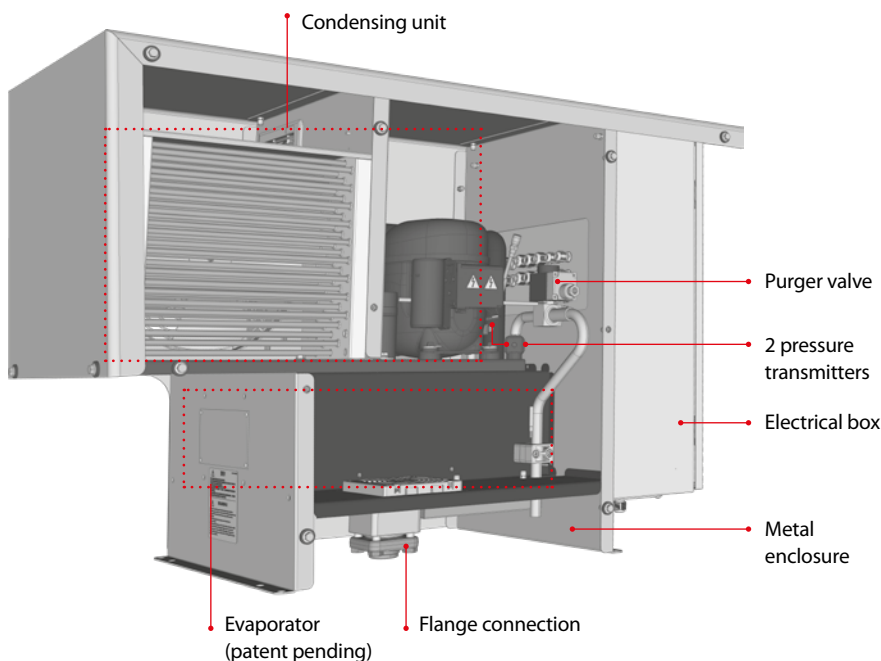

### Technical data

<b>Supply voltage</b>	230V AC, 1ph, 50Hz
<b>Current</b>	3.7 A
<b>Power consumption</b>	1.3 kW
<b>Ambient temp, operation</b>	-10°C to +43°C (14°F to 109°F)
<b>Ambient temp, transport</b>	-30°C to 55°C (-22°F to 131°F)
<b>Enclosure</b>	IP55
<b>Weight</b>	90 kg (199 lbs)
<b>Dimensions (LxWxH)</b>	1051 x 441 x 703 mm (41.4 x 17.4 x 27.7 inches)
<b>Purger refrigerant</b>	R452A 900gram (1 lbs 15.75 oz)
<b>System refrigerant</b>	R717 minimum 6 bar (87 psi)
<b>Max operating pressure (R717)</b>	40 bar (580 psi)
<b>Operating temperature (R717)</b>	-40°C to +60°C (-40°F to +140°F)

## Benefits of the Danfoss IPS 8



### Easy installation and maintenance

- Cost-effective design with few mechanical and electrical connection interfaces
- Minimizes the risk of leakage thanks to the fully brazed internal cooling system
- Plug and play, stand-alone unit eases installation and commissioning – low risk of potential error
- No need for any advanced settings
- Easy to handle with its compact design
- Fast and easy pump down before service



### Maximize system performance

- Automatic purging response to non-condensable gases in the refrigeration system
- Constant high pressure differential between refrigerant and purger refrigerant independent of system suction or condensing pressure
- Reduction of plant power consumption
- 8 point purger functionality



### Improve operational safety

- Electronic purging helps reduce the risk of refrigerant release to the environment
- Self-contained operating unit functions independently from the main plant
- Easy monitoring of past purging cycles data with operation log
- Self-diagnostics for unit and system operation to shut down in case of malfunction of air purger components

Visit [IPS.danfoss.com](https://ips.danfoss.com) to discover more about the new Danfoss IPS