

VACON[®] NXP
AC DRIVES

**GRID CONVERTER
APPLICATION MANUAL**

ARFIFF03

VACON[®]

TABLE OF CONTENTS

Document: DPD01599C
 Software code: ARFIFF03V133
 Version release date: 11.4.2019

1. General	7
1.1 AFE Control	7
1.2 Island (Static Power Supply)	7
1.3 Micro Grid.....	8
1.3.1 Operation principle: Droop Speed Control Mode	9
1.3.2 Operation principle: Isochronous Speed Control Mode	9
1.4 Shaft Generator	10
1.5 Commissioning	11
1.5.1 Quick start instructions	11
1.5.2 In case of parallel AFE:	11
1.6 Charting of DC	13
1.7 Main circuit breaker control (MCB).....	14
1.8 Start Sequence	15
1.9 Stop sequence	16
3.1 afe mode; Start Stop timing diagram.....	17
1.10 Voltage compensation	18
1.11 OPT-D7	19
1.12 Compatibility issues in parameters between versions	20
1.13 Grid Converter units	21
1.13.1 Air cooled 500 Vac Units, 465-800 Vdc.....	21
1.13.2 Air Cooled 690 Vac Units, 640-1100 Vdc	21
1.13.3 Liquid Cooled 500 Vac Units, 465-800 Vdc.....	22
1.13.4 Liquid Cooled 690 Vac Units, 640-1100 Vdc.....	22
1.13.5 Liquid Cooled 690 Vac Units, 640-1200 Vdc.....	22
2. Control I/O	23
3. “Terminal To Function” (TTF) Programming principle “	24
3.1 Defining an input/output for a certain function on keypad	24
4. Monitoring signals	26
4.1 Monitoring value tables.....	26
4.1.1 Monitoring values 1 (Control panel: menu M1.1).....	26
4.1.2 Monitoring values 2 (Control panel: menu M1.2).....	27
4.1.3 Fieldbus monitoring values (Control panel: menu M1.3)	27
4.1.4 I/O monitoring values (Control panel: menu M1.4).....	28
4.1.5 Licence key activation.....	28
4.1.6 Line Monitoring	28
4.2 Description of monitoring values	29
4.2.1 Monitoring 1 values.....	29
4.2.2 Monitoring 2 values.....	32
4.2.3 Fieldbus monitoring values	34
4.2.4 I/O monitoring values.....	40

4.2.5	Activation status.....	41
4.2.6	Line Monitoring.....	42
5.	Parameter list.....	44
5.1	Basic parameters.....	44
5.2	Reference handling.....	44
5.2.1	DC Reference.....	45
5.2.2	Power / Frequency reference.....	45
5.2.3	Reference adjust.....	45
5.2.4	AC voltage reference.....	46
5.3	Ramp control.....	46
5.4	Input signals.....	46
5.4.1	Basic settings.....	46
5.4.2	Digital inputs.....	47
5.4.3	Analogue input 1.....	48
5.4.4	Analogue input 2.....	48
5.4.5	Analogue input 3.....	48
5.4.6	Analogue input 4.....	49
5.5	Output signals.....	49
5.5.1	Digital output signals.....	49
5.5.2	Delayed DO 1.....	50
5.5.3	Delayed DO 2.....	50
5.5.4	Analogue output 1.....	51
5.5.5	Analogue output 2.....	52
5.5.6	Analogue output 3.....	53
5.5.7	Options.....	53
5.6	Limit settings.....	54
5.6.1	Current limit.....	54
5.6.2	Power limit.....	54
5.6.3	Frequency limit.....	54
5.6.4	Micro Grid.....	54
5.6.5	DC voltage.....	55
5.7	Drive control.....	55
5.7.1	AFE control.....	55
5.8	Protections.....	56
5.8.1	General.....	56
5.8.2	Temperature Sensor Protections.....	57
5.8.3	Earth fault.....	57
5.8.4	Fieldbus fault.....	57
5.8.5	External fault.....	58
5.8.6	Grid voltage D7.....	58
5.8.7	Grid frequency.....	58
5.8.8	Voltage.....	58
5.8.9	Over Load.....	58
5.8.10	D7 Protections.....	59
5.8.11	Extra.....	59
5.9	Fieldbus.....	59

5.10	Micro Grid.....	61
5.10.1	Free Select	61
5.11	Synchronisation to external grid	62
5.12	Synchronisation to shaft generator	62
5.13	ID control functions	63
5.13.1	Value control	63
5.13.2	DIN ID control 1	63
5.13.3	DIN ID control 2	63
5.13.4	DIN ID control 3	64
5.13.5	DIN ID control 4	64
5.13.6	Signal Fault function	64
5.14	Auto reset	64
5.15	Grid voltage PI	64
5.16	Keypad control (Control panel: menu M3)	65
5.17	System menu (Control panel: menu M6)	65
5.18	Expander boards (Control panel: menu M7)	65
6.	Description of parameters	66
6.1	Basic parameters	66
6.1.1	Transformer parameters	68
6.2	Reference handling	69
6.2.1	DC Reference Tuning	70
6.2.2	Power /frequency reference	71
6.2.3	Reference adjust functions.....	74
6.2.3.1	Reactive Current Reference.....	74
6.2.3.2	AC Voltage Reference.....	74
6.3	Ramp control	76
6.4	Input signals	77
6.4.1	Basic settings	77
6.4.2	Digital input signals	78
6.4.2.1	Synchronization to external grid.....	80
6.4.2.2	Forced control place.....	82
6.4.3	Analogue inputs 1-4	84
6.4.3.1	Analogue input to any parameter.....	86
6.5	Output signals.....	87
6.5.1	Digital output signals.....	87
6.5.1.1	Fieldbus digital inputs connection	88
6.5.2	Delayed digital output 1 & 2	89
6.5.3	Analogue output 1 & 2 & 3.....	90
6.5.4	Options	93
6.6	Limit settings.....	95
6.6.1	Current limits	95
6.6.2	Power limits.....	97
6.6.3	Frequency limits.....	98
6.6.4	Micro Grid limits.....	99
6.6.5	DC voltage regulators	100
6.7	Drive control	102

6.7.1	AFE Control	105
6.8	Protections.....	107
6.8.1	General settings.....	107
6.8.2	Temperature Sensor Protections	110
6.8.2.1	Individual channel monitoring.....	112
6.8.3	Earth fault.....	113
6.8.4	Fieldbus	113
6.8.5	External fault.....	114
6.8.6	Grid voltage D7	114
6.8.7	Grid frequency.....	115
6.8.8	Supply voltage	116
6.8.9	Over Load Protection	118
6.8.10	D7 protections	119
6.8.11	Extra.....	120
6.9	Fieldbus.....	121
6.10	Micro Grid.....	124
6.10.1.1	Generator Simulation.....	126
6.10.1.2	AFE operation mode selection.....	127
6.11	Synch to external grid	128
6.12	Synch to shaft generator grid	129
6.13	ID functions.....	130
6.13.1	Value control	130
6.13.2	DIN ID control.....	132
6.13.3	Signal Fault Function.....	133
6.14	Auto Reset.....	134
6.15	Grid voltage PI controller.....	135
6.15.1	Grid voltage PI OPT-D7 limits	135
7.	Keypad control parameters	136
8.	FB Status and control in detail.....	137
8.1	FB DC Reference	137
8.2	State machine: Basic.....	138
8.2.1	FB Control Word Basic	138
8.3	State Machine: Standard.....	139
8.3.1	Control Word: Standard.....	139
8.4	State machine: Vacon AFE 1	140
8.4.1	Control Word: Vacon AFE 1	140
8.5	Control Word: Vacon AFE 2 Profile (3)	141
8.6	FB Status Word.....	143
8.7	FB Micro Grid Control Word 1 ID1700.....	145
9.	Problem solving	146
10.	Fault codes	147

1. GENERAL

This application is not kept backwards compatible. See chapter Compatibility issues before you update the application. The Grid Converter application is used to make AC grids with a possibility to operate in parallel with other power sources. The Grid Converter application has 3 different operation modes:

- Standard AFE mode.
- Island mode.
- Micro Grid mode.

1.1 AFE CONTROL

AFE function keeps constant DC voltage. AFE mode transfers power between DC and AC. AFE cannot create grid by itself, it needs to be connected to existing grid.

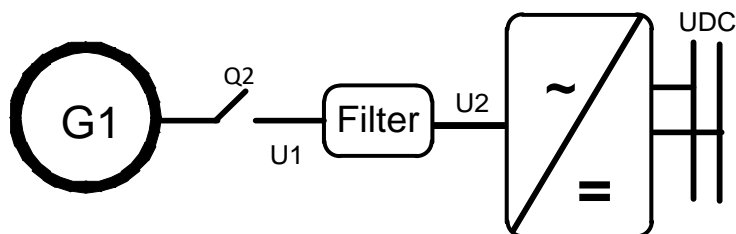

Figure 1.

1.2 ISLAND (STATIC POWER SUPPLY)

Island mode generates constant voltage and frequency. In island mode DC Voltage is not controlled.

Island mode cannot operate in parallel with other power sources in AC side, because the drive will not balance reactive or active power with other power sources.

DC voltage level needs to be considered to have correct voltage on AC side in different load situations, considering voltage losses in LCL filter and in transformer.

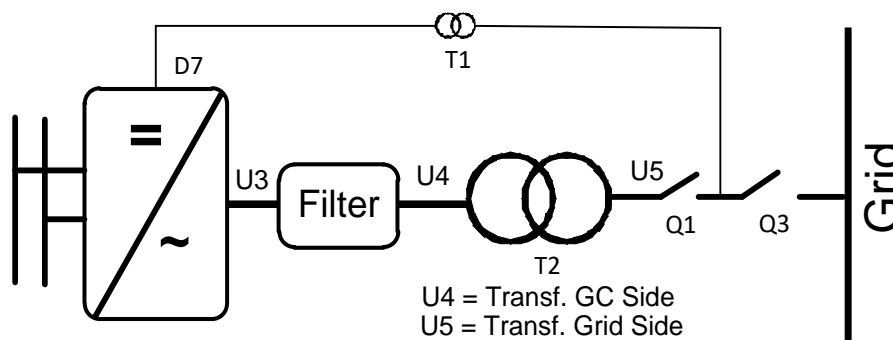

Figure 2.

1.3 MICRO GRID

Micro Grid mode controls the grid voltage and frequency. It functions like an ordinary generator. Micro Grid mode does not control DC Voltage.

With the help of voltage droop and frequency droop, more than one Micro Grid and/or Generators can work together.

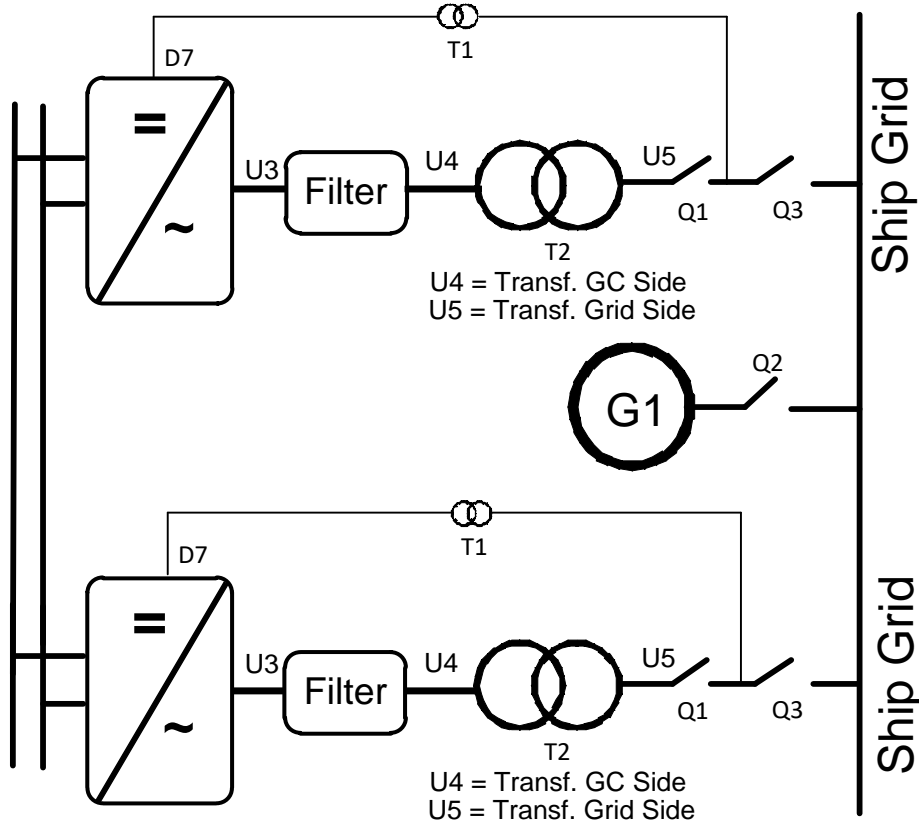

Figure 3.

1.3.1 OPERATION PRINCIPLE: DROOP SPEED CONTROL MODE

When the power demand increases, all generators on the grid allow frequency to droop. This will balance the load between all the generators on the grid. Then the power management system gives all generators a command to increase frequency so that the grid frequency is maintained at its nominal value.

When the load is reducing on the grid, the frequency of the generators will increase, and the power management system gives a command to decrease frequency.

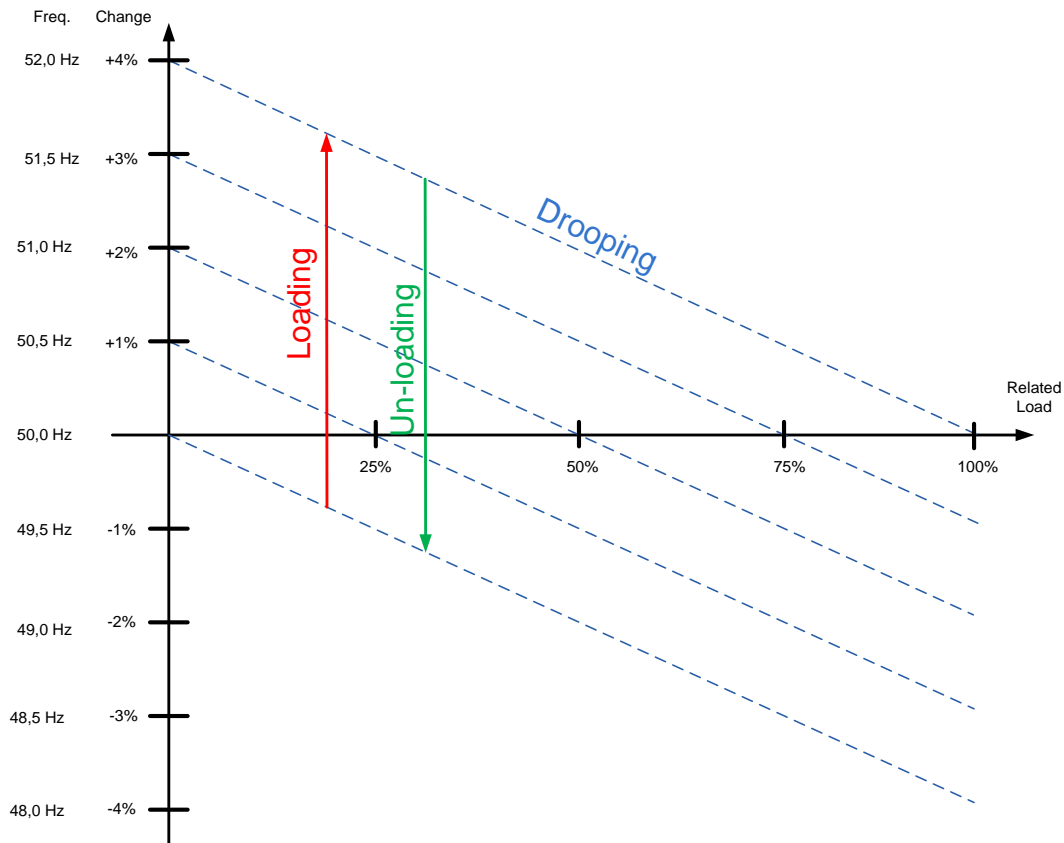

Figure 4.

1.3.2 OPERATION PRINCIPLE: ISOCHRONOUS SPEED CONTROL MODE

In the isochronous speed control mode, the Micro Grid frequency reference is kept the same as the grid frequency with help of OPT-D7. This will keep power at zero regardless of grid frequency. While drive operates in drooping mode, the actual power is controlled by base current reference. This reference needs to be controller by power management system (PMS) that will handle power sharing between different machines on the grid.

1.4 SHAFT GENERATOR

The shaft generator is a system where the generator is connected to the main engine shaft that also runs the main propulsion. The disadvantage is that the main engine must run at nominal speed even if full power to the propeller is not necessary.

With the shaft generator system power goes through the drives. One converts power from the generator to DC link, and the other makes a ship grid with constant 50 Hz or 60 Hz, thus there is no direct connection to the generator. The main engine can run at a more efficient speed without changing grid frequency.

One drive operates as an AFE on the generator side and the other operates on Island mode or Micro Grid mode on the grid side.

- The start command to generator side drive.
- Both drives can make DC charging if powered by +24 Vdc.
- When DC is at an 80% of nominal, the generator side and the grid side breakers close.
- The generator side AFE is started to boost DC first.
- The grid side Grid Converter is started and will synchronise to grid.
- The drives take power from the bypass, and the PMS opens the SG contactor.
- You can decrease the speed of the main diesel engine to be more economical.

NOTE! If it is necessary to have these systems in parallel, the system bus communication is reserved for parallel Micro Grid units on the grid side. The control must be arranged separately for each drive.

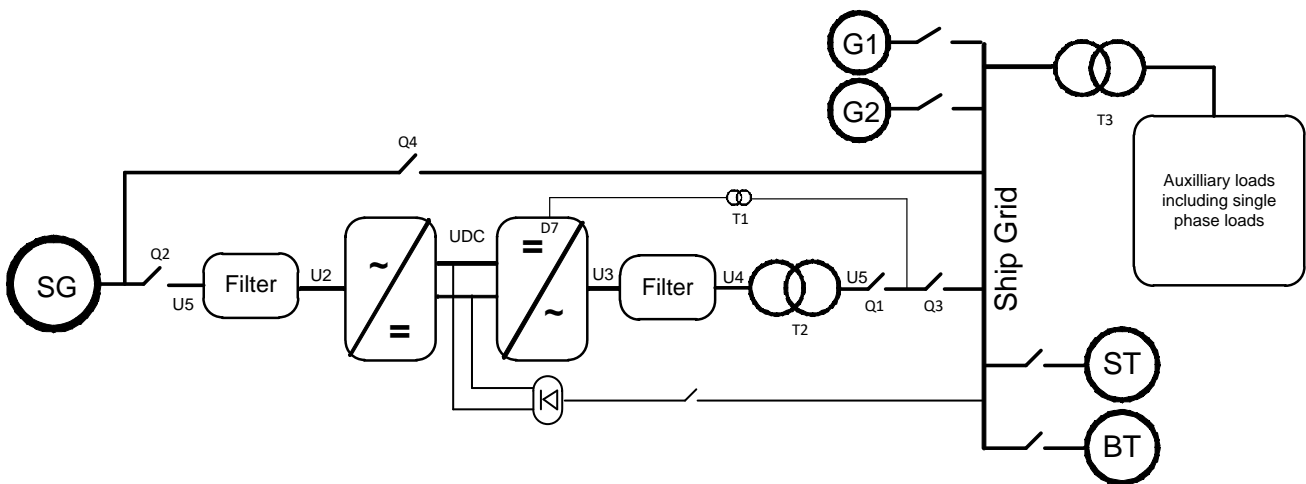

Figure 5.

1.5 COMMISSIONING

NOTE! Before you start the commissioning, read the safety instructions in the user manual of your product.

To use the Island, Micro Grid, or Shaft generator operation, you need a licence key. The AFE mode is available without a licence.

This application requires an NXP3 control board VB761 or newer.

The control place (P3.1) of the Micro Grid drive is Keypad as a default.

The basic I/O configuration of the Micro Grid drive consists of OPT-A1, OPT-A2, and OPT-D7 option boards. The basic I/O configuration is described in Table 1.

OPT-D7 is required when the Micro Grid unit is needed to start with zero power to the grid. If grid frequency is not monitored with OPT-D7, the unit may go generator side or directly to full power because different reference frequency and grid frequency.

The GTC is utilised by using AFE hardware with special software. An external LC(L)-filter and charging circuit is needed. This unit is selected when low harmonics are required. The principle connection of AFE drive has been described in Figure 6.

The external 24 Vdc is recommended for control board(s). It enables the setting of parameters even when the power unit itself is not powered. This is important also when software updates are made. Some default I/O configuration of the application can cause unexpected DO operation. When the control board is powered, the drive can give information from the status of the system if, for example, the drive I/O is used for an overall system monitoring.

The external 24 Vdc is required for the drives in cases where the start command starts the control board-controlled precharging operation.

1.5.1 QUICK START INSTRUCTIONS

1. Connect the unit according to the Figure 6.
2. Power up the control unit with 24 Vdc.
3. Set the basic parameters (G2.1)
4. Check that the digital input parameters (G2.4.2) have been set according to the connections.
5. Change the control place according to the system requirements.
6. Charge the unit.

1.5.2 IN CASE OF PARALLEL AFE:

1. Set P2.1.5 Parallel AFE to *Yes*. This will also set DC Drooping to 3.00% (Default).

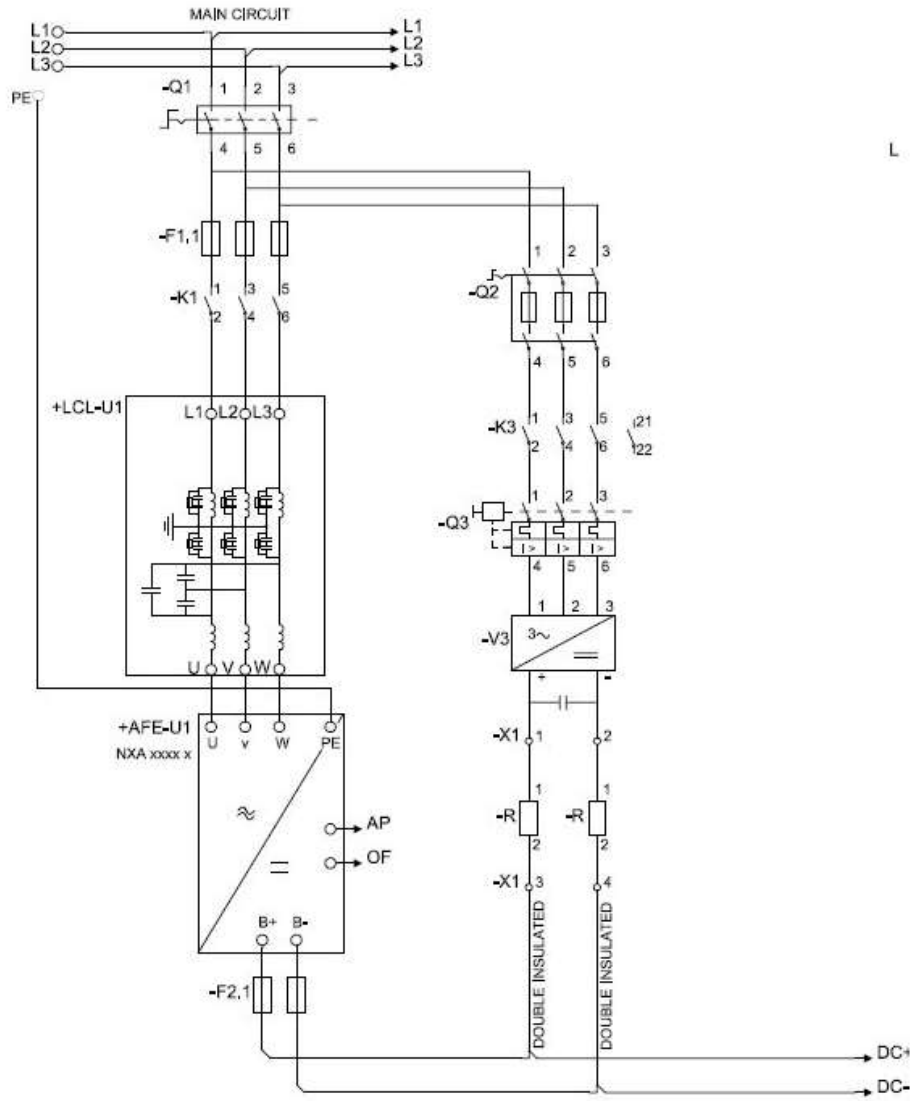

Figure 6. Connection

1.6 CHARTING OF DC

This AFE application has its own charging control, P2.5.1.13 DC Charge (24 Vdc required for control board) and charging protection in case the external charging cannot get DC voltage to required level within set time P2.9.1.6 Charge Max Time (provided that the DC Voltage reaches the under voltage fault level).

The charging function is activated when P2.5.1.13 DC Charge is A.1 or higher. When the control place is IO, Keypad or NCDrive, charging is started from the start command.

Charging is not started if:

- Drive is in fault state.
- P2.4.2.26 Enable CB Close is FALSE
- P2.4.2.8 Run Enable is FALSE
- P2.4.2.19 Quick Stop is FALSE

Charging is also stopped if above conditions occur during charging or if the start command is removed.

For fieldbus control, charging is started with B0 of FB Control Word on the supporting FB profiles. Charging is also stopped if B0 goes low. Also MCB is opened if already closed.

DC Charge (F80) is given if 85 % of DC Nominal is not reached within P2.9.1.6 Charge Max Time and charging is stopped.

DC Charging is stopped when the drive receives feedback from P2.4.2.4 MCB Feedback.

NOTE! Use suitably sized DC Charging resistor. To select the correct size, check Pulse loadability for time duration set in for Max Charge Time parameter.

1.7 MAIN CIRCUIT BREAKER CONTROL (MCB)

The Micro Grid application controls the circuit breaker of the system with the relay output R02. When the DC bus is charged, the MCB will be closed. The status of the MCB is monitored via a digital input. The digital input used for monitoring is selected with parameter P2.3.1.3. Faults can be set to open the MCB by selecting a response to a fault to be *3=Fault, DC OFF*.

An external charging circuit is necessary to charge the DC bus but drive can control this circuit if 24 Vdc is provided for the control board.

Closing limit is 85% of the nominal DC Voltage.
Opening limit is 75% of the nominal DC Voltage.

*Nominal DC Voltage = Grid Nom Voltage (P2.1.1) * 1.35.*

Over Current (F1), Hardware IGBT (F31) and Software IGBT (F41) faults will open MCB immediately to protect the drive.

NOTE! The MCB feedback is necessary for the correct operation of the Grid Converter application.

NOTE! Only the drive controls its own MCB. If additional interlocks or opening commands are needed, these commands must go through the drive.

NOTE! UPS may be needed during short circuit situation to keep MCB closed if control voltage is taken from the grid where the short circuit occurs.

1.8 START SEQUENCE

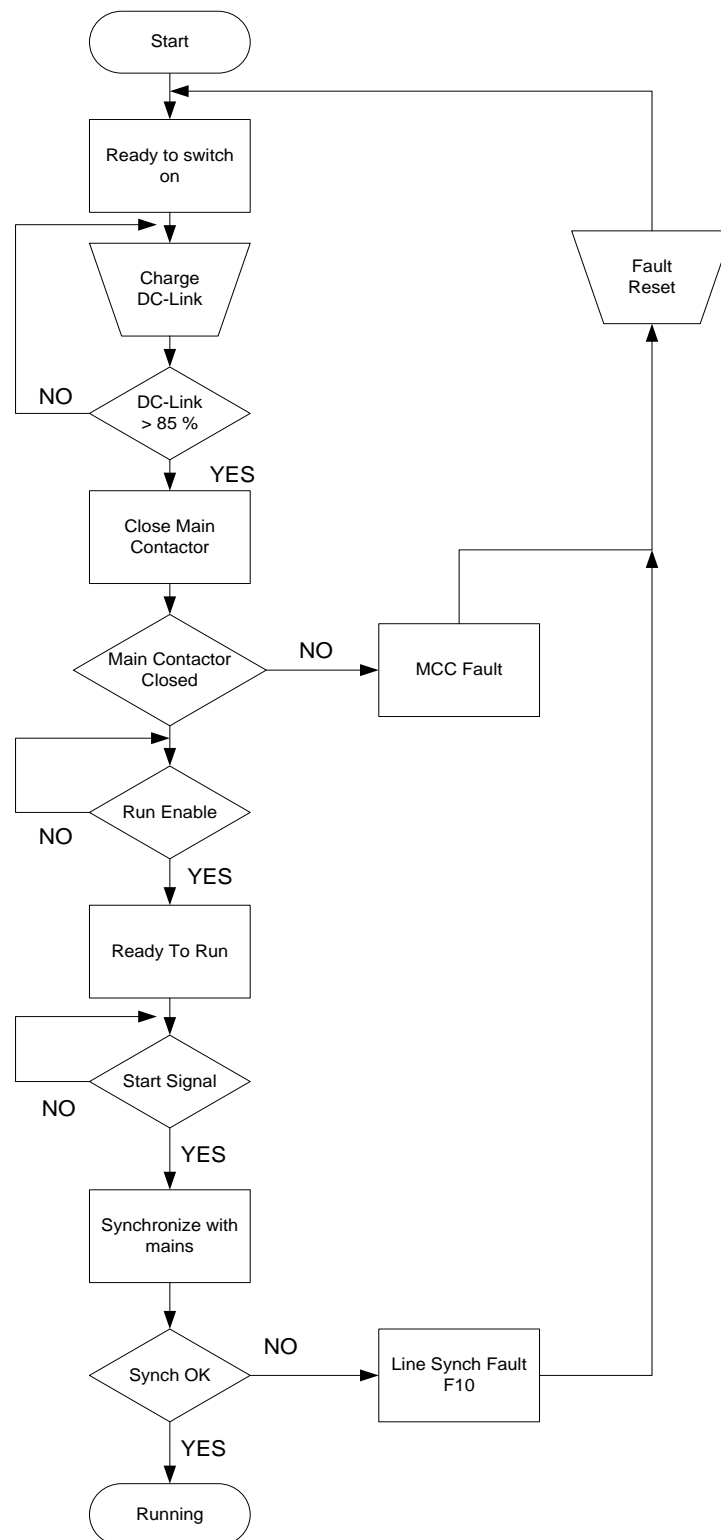

Figure 7. AFE start sequence

1.9 STOP SEQUENCE

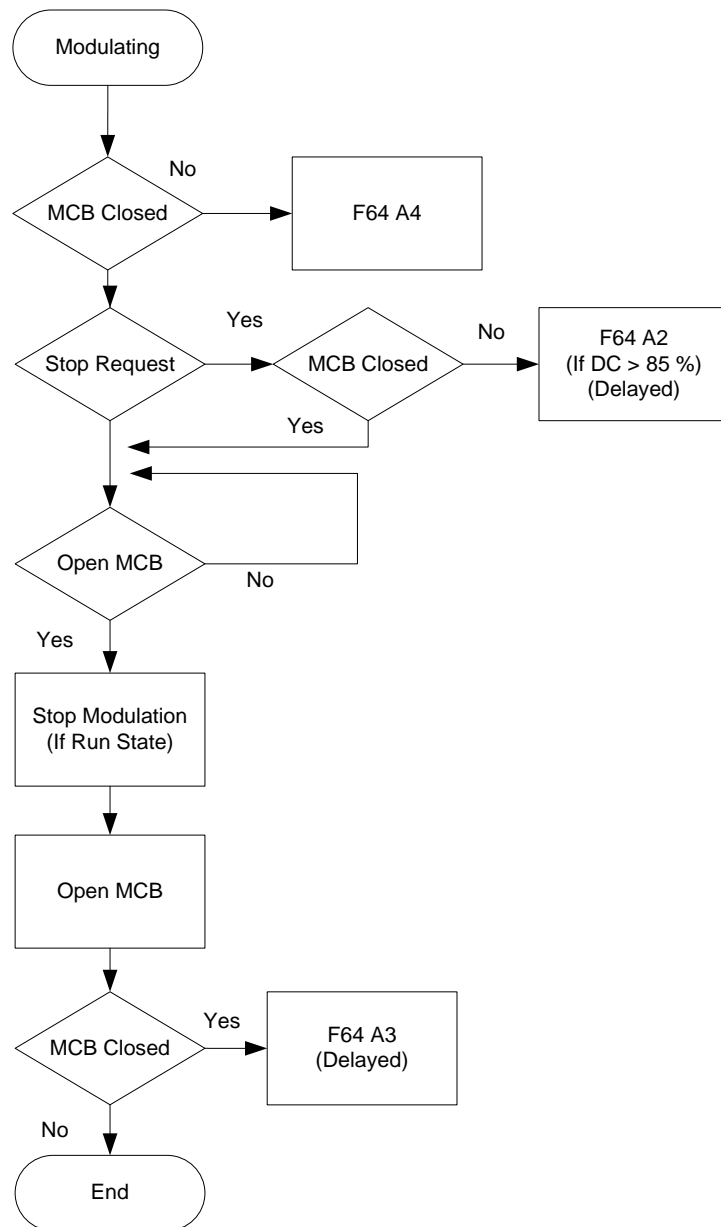
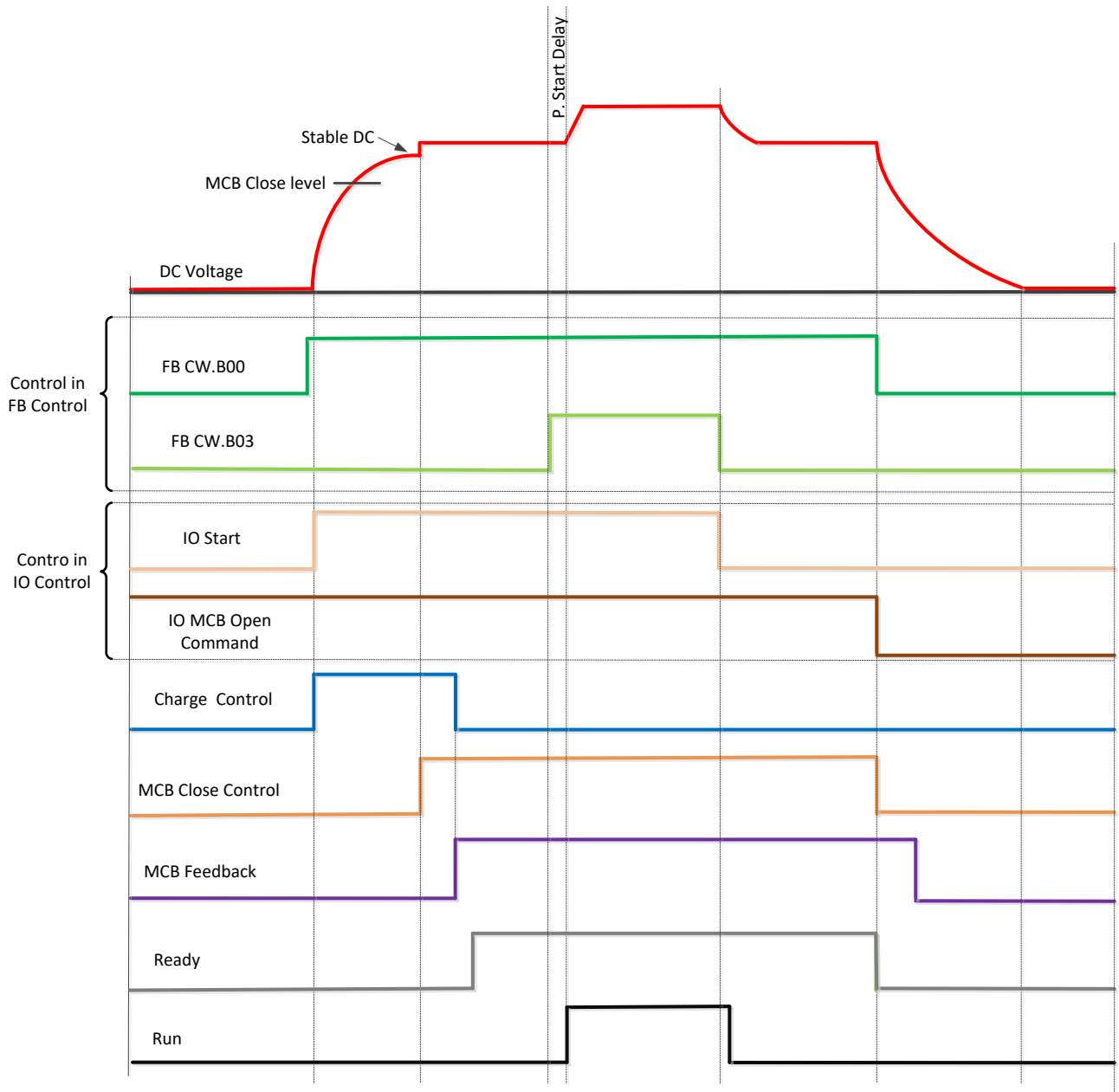

Figure 8. Stop sequence

3.1 AFE MODE; START STOP TIMING DIAGRAM



Above example when "Standard" state machine is used. With "Basic" state machine operation is like in IO Control.

1.10 VOLTAGE COMPENSATION

Grid Converter system will have voltage losses. Depending on the system, the losses may be more than 50 Vac when operating close to Grid Converter nominal currents with low power factor between points U3 and U5. This voltage loss needs to be compensated so that the grid voltage stays at nominal. This also sets requirements for the needed DC link voltage.

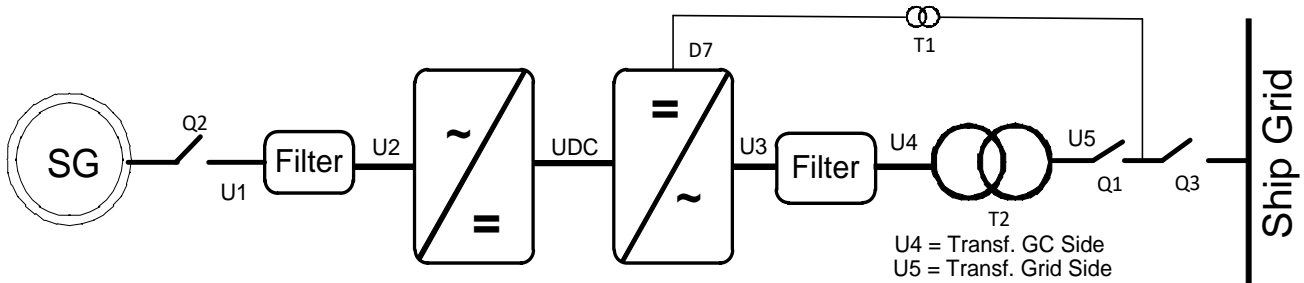

Figure 9. Voltage compensation

The normal operation voltage range in a land-based grid is usually between 80% and 115% of the grid nominal voltage.

The voltage losses compensation is handled separately for Active power (kW) and Reactive power (kVar), the latter being more significant. The Active power voltage losses are compensated with Inductor Losses parameter (P2.2.8.6) and Reactive power voltage losses are compensated with Inductor Size parameter (P2.2.8.5).

Uncompensated system may result in unnecessary reactive power circulation in a grid between the different power sources and wrong grid voltage.

OPT-D7 can be used to compensate the voltage losses (closed loop voltage compensation) but it is recommended to do an open loop voltage compensation tuning in case of OPT-D7 failure. When the OPT-D7 measurements exceed the set limit values, the voltage compensation falls back to open loop control.

Inductor Size and Losses affect

Grid Nom. Voltage: 400 Vac, Reactive Current: 30%, Active Current 50%, Inductor Size: 15%, Inductor Losses: 15%, Voltage Correction: 0 Vac.

Reactive Increase: $400 \text{ Vac} \times 30\% \times 15\% = 18 \text{ Vac}$
 Active Increase: $400 \text{ Vac} \times 50\% \times 15\% \times 15\% = 4.5 \text{ Vac}$
 Total increase: $18 \text{ Vac} + 4.5 \text{ Vac} = 22.5 \text{ Vac}$

See also document: Voltage Compensation Vxxx.pdf.

1.11 OPT-D7

OPTD7 is an AC sinusoidal voltage measurement board. Using this board, the drive measures the line voltage, the frequency and the voltage angle information.

The drive can compare this information with its output voltage angle when it runs. This feature can be used to make synchronisations to a grid that is measured. For example, for line synchronisation purposes you can use APFIFF44 LineSynch II Application. That will work as a smooth starter.

In Micro Grid application this can be used:

- To synchronise to existing external grid while the drive is running to enable bumpless transfer from a generator operation to a shore powered operation in a ship.
- To control the grid voltage (Voltage losses compensation).
- To enable a zero power connection to an existing grid.
- To help in the commissioning of drive active power and reactive power voltage losses compensation when the actual grid voltage is visible in NCDrive.

The OPT-D7 board is delivered with the transformer which is suitable for a voltage range up to 690 Vac. The transformer cannot be used with a pulse width modulated (PWM) voltage input.

It is possible to use a customised transformer when the input voltage to be measured is not within the OPT-D7 transformer voltage range. The transformation ratio parameter can be adjusted according to the transformer primary to secondary ratio. See details in the OPT-D7 user manual.

Synchronisation to the grid can be made without the OPT-D7 when the drive operates in the AFE or the Micro Grid mode. This requires that the output terminals of the drive are connected to the existing grid when the drive is in the STOP state. When a start command has been given in AFE or Micro Grid mode, the drive will make standard AFE synchronisation. Depending on the operation mode, the drive will start to keep constant DC voltage (AFE) or start to share power based on grid frequency (Micro Grid). Using OPT-D7 for synchronisation will make the start of the drive smoother.

If the drive does not detect an existing line voltage or frequency in Micro Grid mode, the output voltage is raised defined time (VoltageRiseTime). In the Island mode, the detection of the grid is not made and the voltage is raised from zero in the set time (VoltageRiseTime).

NOTE: The OPT-D7 board (in slot C) is mandatory for the Grid Converter unit.

1.12 COMPATIBILITY ISSUES IN PARAMETERS BETWEEN VERSIONS

NOTE! This application is not kept backwards compatible. See release notes and this chapter before updating the application.

Update Note 1: When you update the application do not use NCDrive parameter download function. Instead upload parameters from the unit and compare them to the old parameter file. The application is constantly developed, and it includes changing parameter default values. If parameters are directly downloaded to drive, improved default values will be lost.

Update Note 2: If OPT-D7 PI voltage control is needed in uGrid mode, do not use versions V082 or V083.

V092

- **Major Compatibility Issue:** P2.1.7 System Nom. DC is initialized to unit nominal DC value.
 - 500 Vac unit: 675 Vdc
 - 690 Vac unit: 931 Vdc
 - When a transformer ratio other than 1:1 MCB closing limit was given and DC-Link Voltage reference had values based on grid voltage after transformer. This was causing reference handling problems when given AC values were in range of different voltage class unit.
 - DC Voltage Reference in AFE mode is based always to System Nom DC parameter.

V089

- Compatibility Issue: Voltage MotPot is adjusting now field weakening point voltage. Units have been changed from [V] to [%]. This enables more accurate adjustment and adjustment rate.

V087

- Minor Compatibility Issue: FB Actual Speed signal changed to use Filtered DC-Link Voltage signal (ID1108) instead of unfiltered DC Voltage signal.

V081

- Compatibility Issue: Parameters “PID Activation” and “FreqScaleMinA0” had same ID1807. “FreqScaleMinA0” DI changed to ID1809.
- Major Compatibility Issue: Fieldbus State Machine
 - See full details from latest manual.
 - Not Used -> Basic, As in Fieldbus manual
 - Standard -> NEW Standard, Application level, this was < V081 Basic, as in fieldbus manual.
 - FB Status and FB Control word modified to be more suitable for AFE use, following idea of ProfiDrive standard.

V080

- Minor compatibility issue: Monitoring and parameter values unified with other premium drive applications.

V128

- Minor compatibility issue: P2.7.8 Control Options2 B1 is no longer available, this has been replaced with P2.9.1.15 FaultWarnIndicat parameter.

1.13 GRID CONVERTER UNITS

See full details from AFE unit user manual.

Air Cooled: Vacon NX AFE User Manual

Liquid Cooled: Vacon NXP Liquid Cooled Drives User Manual.

Air and liquid-cooled products listed in this chapter are compatible with Grid Converter application ARFIFF03. Hardware and software support for AFE use is only available for these products.

Downloading Grid Converter application to products other than those listed in this chapter is considered to be a non-standard product the functionality of which has not been verified or documented. In such cases, the user takes full responsibility for possible hardware and software problems. Application support is not available for non-standard products.

NOTE: OPT-D7 board is mandatory for Grid Converter unit, placed in C-Slot.

1.13.1 AIR COOLED 500 VAC UNITS, 465-800 VDC

Code + MASG	Frame	IL-cont [A]	IH-cont [A]	Is [A] (2 s)
NXA_0261 5 A0T02SG	1xFI9	261	205	349
NXA_0460 5 A0T02SG	1xFI10	460	385	693
NXA_1300 5 A0T02SG	1xFI13	1300	1150	2070

1.13.2 AIR COOLED 690 VAC UNITS, 640-1100 VDC

Code + MASG	Frame	IL-cont [A]	IH-cont [A]	Is [A] (2 s)
NXA_0170 6 A0T02SG	1xFI9	170	144	245
NXA_0325 6 A0T02SG	1xFI10	325	261	470
NXA_1030 6 A0T02SG	1xFI13	1030	920	1656

1.13.3 LIQUID COOLED 500 VAC UNITS, 465-800 VDC

Code + MASG	Chassis	Ith [A]	II [A]	Ih [A]	Is [A]
NXA02615A0T02WV	CH5	261	237	174	261
NXA03855A0T02WG	CH61	385	350	257	385
NXA05205A0T02WG	CH62	520	473	347	520
NXA07305A0T02WG	CH62	730	664	487	730
NXA09205A0T02WG	CH63	920	836	613	920
NXA11505A0T02WG	CH63	1150	1045	767	1150
NXA16405A0T02WG	CH64	1640	1491	1093	1640
NXA23005A0T02WG	CH64	2300	2091	1533	2300

1.13.4 LIQUID COOLED 690 VAC UNITS, 640-1100 VDC



Code + MASG	Chassis	Ith [A]	II [A]	Ih [A]	Is [A]
NXA02616A0T02WG	CH61	261	237	174	261
NXA03856A0T02WG	CH62	385	350	257	385
NXA05026A0T02WG	CH62	502	456	335	502
NXA07506A0T02WG	CH63	750	682	500	750
NXA11806A0T02WG	CH64	1180	1073	787	1180
NXA15006A0T02WG	CH64	1500	1364	1000	1500
NXA17006A0T02WG	CH64	1700	1545	1133	1700

1.13.5 LIQUID COOLED 690 VAC UNITS, 640-1200 VDC

Code + MASG	Chassis	Ith [A]	II [A]	Ih [A]	Is [A]
NXA02618A0T02WG	CH61	261	237	174	261
NXA03858A0T02WG	CH62	385	350	257	385
NXA05028A0T02WG	CH62	502	456	335	502
NXA07508A0T02WG	CH63	750	682	500	750
NXA11808A0T02WG	CH64	1180	1073	787	1180
NXA15008A0T02WG	CH64	1500	1364	1000	1500
NXA17008A0T02WG	CH64	1700	1545	1133	1700

2. CONTROL I/O

Table 1. Minimum recommended I/O configuration.

OPT-A1			
Terminal		Signal	Description
1	+10V _{ref}	Reference voltage output	Voltage for potentiometer, etc.
2	AI1+	Analogue input 1. Range 0-10V, R _i = 200Ω Range 0-20 mA R _i = 250Ω	Input range selected by jumpers. Default range: Voltage 0 – 10 V
3	AI1-	I/O Ground	Ground for reference and controls
4	AI2+	Analogue input 2. Range 0-10V, R _i = 200Ω Range 0-20 mA R _i = 250Ω	Input range selected by jumpers. Default range: Current 0 – 20 mA
5	AI2-		
6	+24V	Control voltage output	Voltage for switches, etc. max 0.1 A
7	GND	I/O ground	Ground for reference and controls
8	DIN1	Programmable G2.2.1	
9	DIN2	Programmable G2.2.1	
10	DIN3	Programmable G2.2.1	
11	CMA	Common for DIN 1– DIN 3	Connect to GND or +24V
12	+24V	Control voltage output	Voltage for switches (see #6)
13	GND	I/O ground	Ground for reference and controls
14	DIN4	MCB Feedback Programmable G2.2.1	0 = MCB open 1 = MCB closed
15	DIN5	Quick Stop Programmable G2.2.1	0 = Quick Stop Active 1 = No Quick Stop
16	DIN6	Programmable G2.2.1	
17	CMB	Common for DIN4– DIN6	Connect to GND or +24V
18	AO1+	Analogue output 1	Programmable Range 0– 20 mA/R _L , max. 500Ω
19	AO1-		
20	DO1	Digital output READY	Programmable P2.3.1.1 Open collector, I _s ≤50mA, U _s ≤48 VDC
OPT-A2			
21	RO1	 Relay output 1 Programmable P2.3.1.2	Switching capacity 24 VDC / 8 A 250 VAC / 8 A 125 VDC / 0.4 A
22	RO1		
23	RO1		
24	RO2	 Relay output 2 MCB control	This RO is not programmable. Fixed for MCB Control (Close)
25	RO2		
26	RO2		

3. “TERMINAL TO FUNCTION” (TTF) PROGRAMMING PRINCIPLE “

The programming principle of the input and output signals in the Multipurpose Control Application NXP as well as in the Pump and Fan Control Application (and partly in the other applications) is different compared to the conventional method used in other VACON® NX applications.

In the conventional programming method, Function to Terminal Programming Method (FTT), you have a fixed input or output that you define a certain function for. The applications mentioned above, however, use the Terminal to Function Programming method (TTF) in which the programming process is carried out the other way round: Functions appear as parameters which the operator defines a certain input/output for. See Warning on page 12.

3.1 DEFINING AN INPUT/OUTPUT FOR A CERTAIN FUNCTION ON KEYPAD

Connecting a certain input or output with a certain function (parameter) is done by giving the parameter an appropriate value. The value is formed of the Board slot on the VACON® NX control board (see VACON® NX User Manual) and the respective signal number, see below.

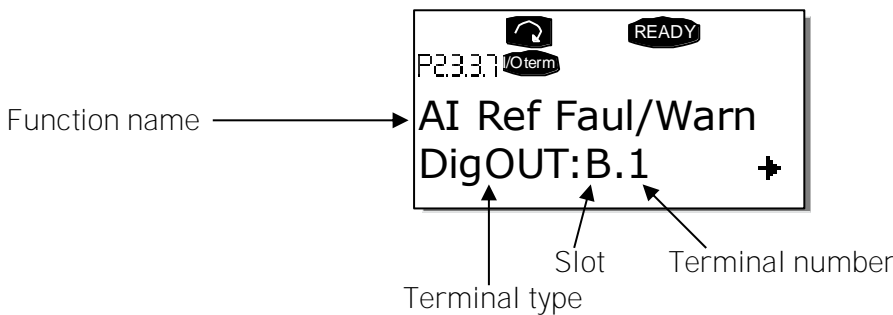

Example: You want to connect the digital output function Reference fault/warning (parameter 2.3.3.7) to the digital output DO1 on the basic board NXOPTA1 (see VACON® NX User Manual).

First find the parameter 2.3.3.7 on the keypad. Press the Menu button right once to enter the edit mode. On the value line, you will see the terminal type on the left (DigIN, DigOUT, An.IN, An.OUT) and on the right, the present input/output the function is connected to (B.3, A.2 etc.), or if not connected, a value (0.#).

When the value is blinking, hold down the Browser button up or down to find the desired board slot and signal number. The program will scroll the board slots starting from 0 and proceeding from A to E and the I/O selection from 1 to 10.

Once you have set the desired value, press the Enter button once to confirm the change.

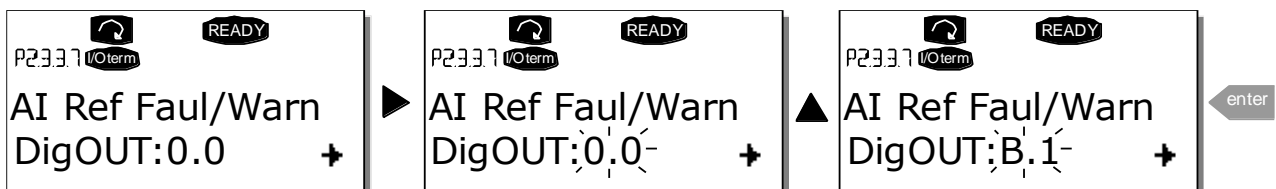

4.2 Defining a terminal for a certain function with NCDrive programming tool

If you use the VACON® NCDrive Programming Tool for parametrizing you will have to establish the connection between the function and input/output in the same way as with the control panel. Just pick the address code from the drop-down menu in the Value column (see the Figure below).

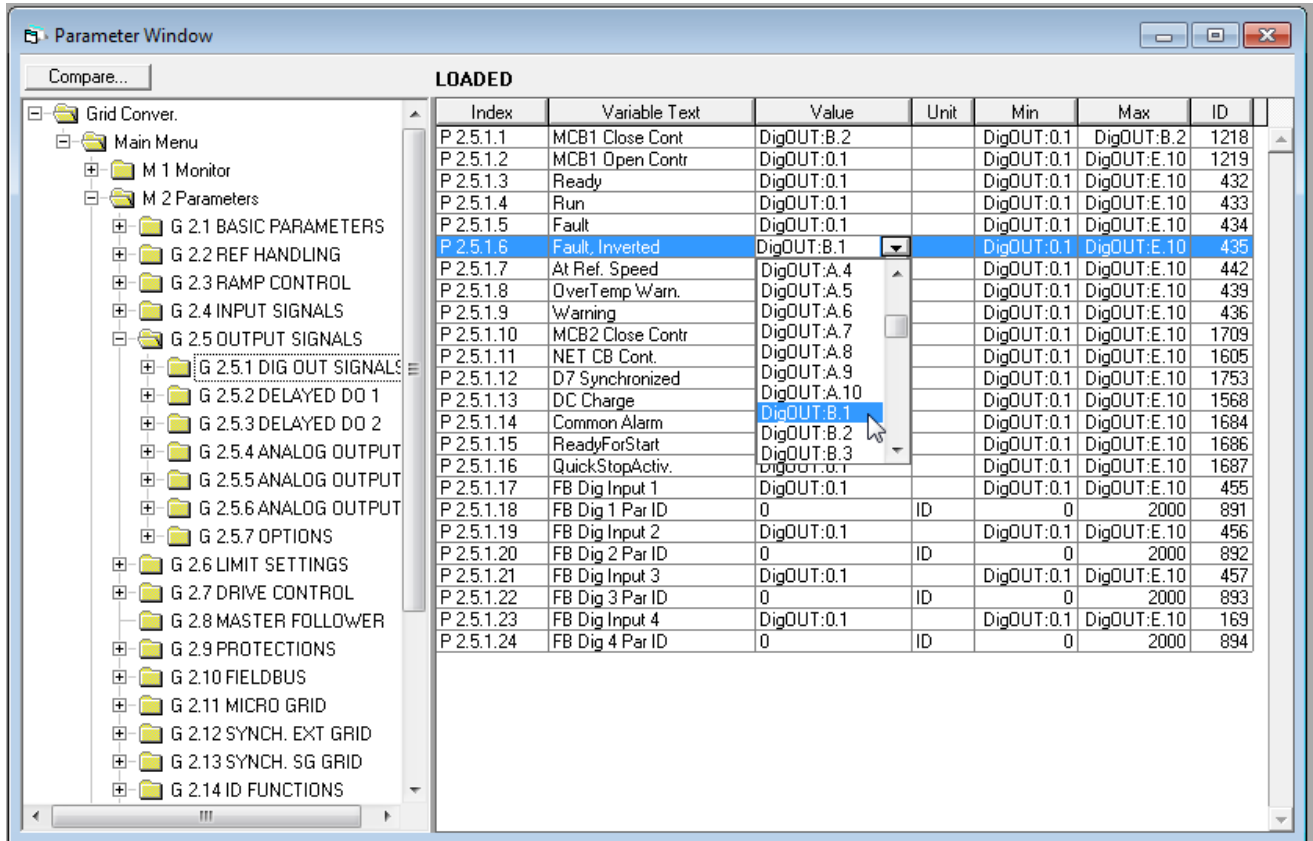

Figure 4 1. Screenshot of NCDrive programming tool; Entering the address code



WARNING

Be **ABSOLUTELY** sure not to connect two functions to one and same output in order to avoid function overruns and to ensure flawless operation.

Note: The *inputs*, unlike the *outputs*, cannot be changed in RUN state.

4. MONITORING SIGNALS

The menu M1 (Monitoring) has all the monitoring values. Values are only for monitoring, and cannot be altered on the control panel.

4.1 MONITORING VALUE TABLES

4.1.1 MONITORING VALUES 1 (CONTROL PANEL: MENU M1.1)

Code	Parameter	Unit	Form.	ID	Description
V1.1.1	DC-Link Voltage	V	#	1108	Measured DC Link voltage in volts, filtered.
V1.1.2	DC Voltage Ref.	%	#,##	1200	Used DC voltage reference by the regenerative unit in % of Nominal DC voltage. Nominal DC voltage = 1.35 * supply voltage
V1.1.3	DC Voltage Act.	%	#,##	7	Same scaling as DC Voltage Ref.
V1.1.4	Total Current	A	Varies	1104	Filtered current
V1.1.5	Active Current	%	#, #	1125	> 0 power from AC side to DC side < 0 power from DC side to AC side
V1.1.6	Reactive Current	%	#, #	1157	
V1.1.7	Power kW	kW	Varies	1508	> 0 power from AC side to DC side < 0 power from DC side to AC side
V1.1.8	Power %	%	#, #	5	> 0 power from AC side to DC side < 0 power from DC side to AC side
V1.1.9	Status Word		#	43	
V1.1.10	Supply Frequency	Hz	#,##	1	Drive output frequency
V1.1.11	Supply Voltage	V	#, #	1107	Drive output voltage
V1.1.12	Line Frequency D7	Hz	#,##	1654	Measured line frequency
V1.1.13	Line Voltage D7	V	#	1650	Measured line voltage
V1.1.14	AC Voltage Reference	V	#	1556	Used AC Voltage Reference
V1.1.15	DC Ref Max Lim	%	#,##	1606	Internal limit for DC Voltage Ref.

4.1.2 MONITORING VALUES 2 (CONTROL PANEL: MENU M1.2)

Code	Parameter	Unit	Form.	ID	Description
V1.2.1	DC Voltage	V	#	44	Measured DC Link voltage in volts, unfiltered.
V1.2.2	Operation Mode		#	1615	0 = AFE 1 = Island 2 = Micro Grid
V1.2.3	Used Current Ref	%	#, #	1704	Used current reference is negated to parameter value. Made to compare values in NCDrive easier to Active current
V1.2.4	D7 Synch. Error		#	1659	Synchronisation error to external grid
V1.2.5	Cos Phi Actual		#,###	1706	
V1.2.6	Unit Temperature	°C	#	1109	
V1.2.7	Freq. Reference	Hz	#, #	1752	Used line frequency reference
V1.2.8	Current	A	Varies	1113	Unfiltered current
V1.2.9	SG Synch Error		#	1658	Synchronisation error to shaft generator side
V1.2.10	Operation Hours	h	#,###	1856	
V1.2.11	Reactive Current Reference	%	#, #	1389	
V1.2.12	Grid State		#	1882	
V1.2.13	Mindex	%	#, #	1858	Modulation Index
V1.2.14	Phase U Current	A	Varies	39	rms, 1 second linear filtering
V1.2.15	Phase V Current	A	Varies	40	rms, 1 second linear filtering
V1.2.16	Phase W Current	A	Varies	41	rms, 1 second linear filtering

4.1.3 FIELDBUS MONITORING VALUES (CONTROL PANEL: MENU M1.3)

Code	Parameter	Unit	Form.	ID	Description
V1.3.1	FB Control Word		#	1160	Control word from fieldbus
V1.3.2	FB Status Word		#	68	Status word to fieldbus
V1.3.3	Fault Word 1		#	1172	
V1.3.4	Fault Word 2		#	1173	
V1.3.5	Warning Word 1		#	1174	
V1.3.6	FB Micro Grid CW1		#	1700	Control for Micro Grid operations
V1.3.7	FB Micro Grid SW1		#	1701	Status of Micro Grid operations
V1.3.8	Last Active Warning		#	74	
V1.3.9	Last Active Fault		#	37	
V1.3.10	MC Status		#	64	
V1.3.11	FB Analogue Out		#,###	48	

4.1.4 I/O MONITORING VALUES (CONTROL PANEL: MENU M1.4)

Code	Parameter	Unit	Form.	ID	Description
V1.4.1	DIN1, DIN2, DIN3		#	15	
V1.4.2	DIN4, DIN5, DIN6		#	16	
V1.4.3	DIN Status 1		#	56	
V1.4.4	DIN Status 2		#	57	
V1.4.5	Analogue Input 1	%	#,##	13	
V1.4.6	Analogue Input 2	%	#,##	14	
V1.4.7	Analogue input 3	%	#,##	27	AI3, unfiltered.
V1.4.8	Analogue input 4	%	#,##	28	AI4, unfiltered.
V1.4.9	Analogue Out 1	%	#,##	26	
V1.4.10	Analogue Out 2	%	#,##	50	AO2
V1.4.11	Analogue Out 3	%	#,##	51	AO3
V1.4.12	PT100 Temp. 1	°C	#, #	50	
V1.4.13	PT100 Temp. 2	°C	#, #	51	
V1.4.14	PT100 Temp. 3	°C	#, #	52	
V1.4.15	PT100 Temp. 4	°C	#, #	69	
V1.4.16	PT100 Temp. 5	°C	#, #	70	
V1.4.17	PT100 Temp. 6	°C	#, #	71	

4.1.5 LICENCE KEY ACTIVATION

Code	Parameter	Unit	Form.	ID	Description
V1.6.1	Serial Number Key		#	1997	Give this number to the technical support of the manufacturer in case of licence key problems.
V1.6.2	Licence Status		#	1996	

4.1.6 LINE MONITORING

Code	Parameter	Unit	Form.	ID	Description
V1.7.1	Line Voltage D7	Hz	#,##	1654	Measured line voltage
V1.7.2	Line Frequency D7	V	#	1650	Measured line frequency
V1.7.3	Line Voltage THD	%	#,##	1670	Line voltage total harmonic distortio
V1.7.4	Line Voltage HF RMS	V	#, #	1671	RMS of high frequency components

4.2 DESCRIPTION OF MONITORING VALUES

4.2.1 MONITORING 1 VALUES

V1.1.1 *DC-Link Voltage* *V* *ID1108*

The measured DC voltage, filtered.

V1.1.2 *DC Voltage Ref.* *%* *ID1200*

The DC voltage reference. Percentage value of P: System Nom DC. If System Nom DC is not given this is scaled to P: Grid Nom Voltage.

V1.1.3 *DC Voltage Act.* *%* *ID7*

Actual DC Voltage. Percentage value of P: System Nom DC. If System Nom DC is not given this is scaled to P: Grid Nom Voltage.

V1.1.4 *Total Current* *A* *ID 1113*

The filtered current of the drive.

V1.1.5 *Active Current* *%* *ID 1125*

The active current in % of System Rated Current.
A negative value means that the current is flowing to AC side from DC side.

V1.1.6 *Reactive Current* *%* *ID 1157*

The reactive current of the regenerative drive in % of System Rated Current.

V1.1.7 *Power kW* *kW* *ID 1508*

The output power of the drive in kW.
A negative value means that the current is flowing to AC side from DC side.

V1.1.8 *Power %* *%* *ID 5*

The output power of the drive in %. 100,0 % equals 100.0 % Active Current and 100.0 % Supply Voltage.

A negative value means that the current is flowing to AC side from DC side.

V1.1.9 Status Word (Application)**ID 43**

The Application Status Word combines different statuses of the drive to one data word.

Status Word (Application) ID43		
	FALSE	TRUE
b0	DO Charge FALSE	DO Charge TRUE
b1	Not in Ready state	Ready
b2	Not Running	Running
b3	No Fault	Fault
b4	No Start Request	Start Request active
b5	Quick stop active	Quick stop not active
b6	Run Disabled	Run Enable
b7	No Warning	Warning
b8	Internal Charge Open	Charging Switch closed (internal)
b9	MCB Controlled open	MCB Controlled Closed
b10	MCB Feedback FALSE	MCB Feedback TRUE
b11		
b12	No Run Request	Run Request
b13	Not at current limit	At Current Limit
b14	AFE Mode Active	Island Mode Active
b15		uGrid Mode Active

V1.1.10 Supply Frequency *Hz* **ID 1**

The drive output frequency. Updated in the STOP state when Regen Option B9 is activated.

V1.1.11 Supply Voltage *V* **ID 1107**

The drive output voltage.

V1.1.12 Line Frequency D7 *Hz* **ID 1654**

The measured line voltage frequency when using the OPT-D7 option board in slot C.

When the OPT-D7 board is not used, it is possible to use Analogue Input 3 and 4 ID write function to give the grid the Line Frequency and Line Voltage. This enables use of grid PI voltage controller without the OPT-D7 board. Note that both line frequency and line voltages needs to be given. By activating Control Options 2 B2 these analogue inputs can be used also to grid protection.

V1.1.13 Line Voltage D7 *V* **ID 1650**

The measured line voltage rms value when using the OPT-D7 option board in slot C.

When the OPT-D7 board is not used, it is possible to use Analogue Input 3 and 4 ID write function to give the grid the Line Frequency and Line Voltage. This enables use of grid PI voltage controller without the OPT-D7 board. Note that both line frequency and line voltages needs to be given. By activating Control Options 2 B2 these analogue inputs can be used also to grid protection.

V1.1.14 AC Voltage Reference V ID 1556

The used AC voltage reference.

V1.1.15 DC Voltage Max Limit % ID 1606

The drive will limit the DC reference to inside drive specification, but allows higher reference if lower supply voltage. This shows the final limit of the DC reference.

4.2.2 MONITORING 2 VALUES

<i>V1.2.1</i>	<i>DC Voltage</i>	<i>V</i>	<i>ID 44</i>
	The measured DC voltage, unfiltered.		
<i>V1.2.2</i>	<i>Operation Mode</i>		<i>ID 1615</i>
	The active Grid Converter operation mode.		
	0 = AFE operation		
	1 = Island operation		
	2 = Micro Grid Operation		
<i>V1.2.3</i>	<i>Used Current Ref</i>	<i>%</i>	<i>ID 1704</i>
	The used current reference. The value is negative to the set parameter to make the monitoring easier in NCDrive.		
<i>V1.2.4</i>	<i>D7 Synch. Error</i>		<i>ID 1659</i>
	An error on voltage angles between the drive and the measurement taken by OPT-D7.		
	-3072...+3071 = -180...180 degrees.		
	If the value is not near to zero when running in AFE mode, the phase order may be wrong even if the OPT-D7 frequency is correct (Error about 2047 = 120 degree). If the measurement is after the Dyn11 transformer, the error is usually about 512 (30.0 Degrees).		
<i>V1.2.5</i>	<i>CosPhiActual</i>		<i>ID 1706</i>
	The calculated Cos Phi.		
<i>V1.2.6</i>	<i>Unit Temperature</i>	<i>°C</i>	<i>ID 1109</i>
	The heatsink temperature of the drive.		
<i>V1.2.7</i>	<i>Frequency Reference</i>	<i>Hz</i>	<i>ID1752</i>
	The used frequency reference. In AFE mode, the frequency reference is determined internally when the synchronisation is made. In Island and Micro Grid mode, the reference is used for a static power supply, and a power drooping in Micro Grid mode.		
<i>V1.2.8</i>	<i>Current</i>	<i>A</i>	<i>ID 1113</i>
	The unfiltered current of the drive.		
<i>V1.2.9</i>	<i>SG Synch Error</i>		<i>ID 1658</i>
	A synchronisation error to the shaft generator frequency.		

4.2.3 FIELDBUS MONITORING VALUES

V1.3.1 FB Control Word ID 1160

The control word from fieldbus. The table below is for "2 / Vacon AFE 1" Selection (P2.10.19) in bypass operation for such fieldbus board that natively supports this or can be parameterised to bypass mode. See other profile selections from chapter Status and Control Word.

FB Control Word ID1160		
	Signal	Comment
b0	DC Charge	0 = Open MCB. 1 = Close DC charge contactor, MCB closed automatically.
b1		
b2		
b3	Start	0 = Stop Command 1 = Start Command
b4		
b5		
b6		
b7	Reset	0>1 Reset fault.
b8		
b9		
b10	Fieldbus Control	0 = No control from fieldbus 1 = Control from fieldbus
b11	Watchdog	0>1>0>1...0.5 s square wave clock. This is used to check data communication between the fieldbus master and the drive.
b12	FB DIN2	Can be used to control R0 or the parameter directly by ID number. G2.4.1
b13	FB DIN3	Can be used to control R0 or the parameter directly by ID number. G2.4.1
b14	FB DIN4	Can be used to control R0 or the parameter directly by ID number. G2.4.1
b15		

V1.3.2 *FB Status Word ID 68*

This is referred as GeneralStatusWord in the fieldbus manual. See details in the fieldbus manual.

FB Status Word ID68		
	Signal	Comment
b0	Ready On	0 = Drive not ready to charge 1 = Drive ready to charge
b1	Ready Run	0 = Drive not ready to run 1 = Drive ready to run and MCB is ON
b2	Running	0 = Drive not running 1 = Drive running with regenerative control ON
b3	Fault	0 = No active fault 1 = Fault is active
b4	Run Enabled	0 = Run Disabled by I/O Commands 1 = Run Enabled by I/O Commands
b5	Quick Stop	0 = Quick Stop Active 1 = Quick Stop Not Active
b6	Switch On Inhibit	0 = CB Control OK 1 = CB Requested open but DC is high
b7	Warning	0 = No warning 1 = Warning active
b8	At Reference	0 = DC Voltage Ref and Act DC Voltage are not same. 1 = DC Voltage Ref and Act DC Voltage are same.
b9	Fieldbus Control Active	0 = Fieldbus control not active 1 = Fieldbus control active
b10	Above Limit	0 = DC voltage is below the level specified by P2.5.7.4 1 = The DC voltage is above the level specified by P2.5.7.4
b11	FB_SW_B11	Select bit in G2.10 Fieldbus
b12	FB_SW_B12	Select bit in G2.10 Fieldbus
b13	FB_SW_B13	Select bit in G2.10 Fieldbus
b14	FB_SW_B14	Select bit in G2.10 Fieldbus
b15	Watchdog	

V1.3.3 *Fault Word 1*

ID 1172

	Fault Word 1
Bit	Fault(s)
B0	F1 Over current, F31 IGBT, F41 IGBT
B1	F2 Over Voltage
B2	F9 Under Voltage
B3	F91 Short Circuit
B4	F3 Earth Fault
B5	
B6	F14 Unit Over Temperature
B7	F16 Motor Temperature, F29 Thermistor, F56 PT100
B8	F10 Line Synch fault
B9	
B10	
B11	F52 Keypad or F52 PC communication fault
B12	F53 FieldBus fault
B13	F59 System Bus fault
B14	F54 Slot Communication fault
B15	F50 4mA fault

V1.3.4 *Fault Word 2*

ID 1173

	Fault Word 2
Bit	Fault(s)
B0	F11 Output phase
B1	
B2	
B3	
B4	
B5	
B6	F51 External fault
B7	
B8	
B9	F31 IGBT, F41 IGBT
B10	
B11	
B12	
B13	
B14	F64 Main Switch State fault
B15	

V1.3.5 Warning Word 1 ID 1174

Warning Word 1 ID1174	
Bit	Warning(s)
B0	W91 Short Circuit
B1	
B2	
B3	
B4	
B5	
B6	F53 FB Warning Slot D
B7	F67 FB Warning Slot E
B8	F14 Over Temperature
B9	
B10	
B11	
B12	
B13	
B14	
B15	

V1.3.6 FB Micro Grid CW1 ID 1700

Control for the Micro Grid operations.

FB Micro Grid CW1 ID1700		
	Signal	Comment
b0	Start As Island	If B11 = False, mode changed in STOP state.
b1	Start As Micro Grid	If B11 = False, mode changed in STOP state.
b2	Start synchronisation D7	Synchronization to external grid with OPT-D7
b3		
b4	Power Down	Same as P2.2.6.2
b5	Power Up	Same as P2.2.6.3
b6	Reset MotPot	Same as P2.4.2.27
b7		
b8		
b9		
b10	Enable FB Control Mode	B0 and B1, is controllable from FB otherwise parameter
b11	Live Mode Control	Operation mode is changed in Run State
b12	P2.10.27 uCW B12	
b13	P2.10.28 uCW B12	
b14	P2.10.29 uCW B12	
b15	P2.10.30 uCW B12	

V1.3.7 *FB Micro Grid SW1* *ID 1701*

Status of the Micro Grid operations.

Micro Grid Status Word		
	Signal	Comment
b0	Charge Control active	Charging
b1	Internal Charging switch status	
b2	MCB control	
b3	MCB status	
b4	Run Enabled	
b5	Drive Ready	
b6	AFE mode active	
b7	Island mode active	
b8	Micro Grid mode active	
b9	Run Request active	
b10	Drive in run state	
b11	Fault Active	
b12	SynchronizedToD7	
b13		
b14	D7 measurements OK	
b15		

V1.3.8 *Warning* *ID 74*

The number of the last active warning.

V1.3.9 *Last Active Fault* *ID 37*

The number of the last active fault.

V1.3.10 MC Status ID 64

For the fieldbuses that do not have their own state machine, this value is sent to fieldbus.

Motor Control Status Word		
	FALSE	TRUE
b0	Not in Ready state	Ready
b1	Not Running	Running
b2	Direction Clockwise	Counter clockwise
b3	No Fault	Fault
b4	No Warning	Warning
b5		At reference speed
b6		At Zero Speed
b7		Flux Ready
b8		TC Speed Limiter Active
b9	Encoder Direction	Counter clockwise
b10		Under Voltage Fast stop
b11	No DC brake	DC Brake is active
b12		
b13		Restart delay active
b14		
b15		

V1.3.11 FB Analogue Out ID 48

Fieldbus value to control analogue output.

4.2.4 I/O MONITORING VALUES

V1.4.1 *DIN1, DIN2, DIN3* *ID 15*

V1.4.2 *DIN4, DIN5, DIN6* *ID 16*

	DIN1/DIN2/DIN3 status	DIN4/DIN5/DIN6 status
b0	DIN3	DIN6
b1	DIN2	DIN5
b2	DIN1	DIN4

V1.4.3 *DIN Status 1* *ID 56*

V1.4.4 *DIN Status 2* *ID 57*

	DIN StatusWord 1	DIN StatusWord 2
b0	DIN: A.1	DIN: C.5
b1	DIN: A.2	DIN: C.6
b2	DIN: A.3	DIN: D.1
b3	DIN: A.4	DIN: D.2
b4	DIN: A.5	DIN: D.3
b5	DIN: A.6	DIN: D.4
b6	DIN: B.1	DIN: D.5
b7	DIN: B.2	DIN: D.6
b8	DIN: B.3	DIN: E.1
b9	DIN: B.4	DIN: E.2
b10	DIN: B.5	DIN: E.3
b11	DIN: B.6	DIN: E.4
b12	DIN: C.1	DIN: E.5
b13	DIN: C.2	DIN: E.6
b14	DIN: C.3	
b15	DIN: C.4	

V1.4.5 *Analogue Input 1* % *ID 13*

V1.4.6 *Analogue Input 2* % *ID 14*

V1.4.7 *Analogue Input 3* % *ID 27*

V1.4.8 *Analogue Input 4* % *ID 28*

The unfiltered analogue input level.

0% = 0 mA / 0 V, -100% = -10 V, 100% = 20 mA / 10 V. Monitoring scaling is determined by the option board parameter. It is possible to adjust this input value from fieldbus when the input terminal selection is 0.1. This way it is possible to adjust the free analogue input from fieldbus and have all the analogue input functions available for fieldbus process data.

V1.4.9 *Analogue Out 1* % *ID 26*

V1.4.10 *Analogue Out 2* % *ID 50*

V1.4.11 *Analogue Out 3* % *ID 51*

Analogue Output value 0% = 0 mA / 0 V, 100% = 20 mA / 10 V

V1.4.12	PT100 Temp. 1	°C	ID 50
V1.4.13	PT100 Temp. 2	°C	ID 51
V1.4.14	PT100 Temp. 3	°C	ID 52
V1.4.15	PT100 Temp. 4	°C	ID 69
V1.4.16	PT100 Temp. 5	°C	ID 70
V1.4.17	PT100 Temp. 6	°C	ID 71

A separate measurement from two PT100 board. The signal has a 4 s filtering time.

4.2.5 ACTIVATION STATUS

V1.6.1	Serial Number Key	ID 1997
--------	-------------------	---------

Give this number to the technical support of the manufacturer when there is a problem in the activation of a function. The drive shows a licence fault.

V1.6.2 Licence Status *ID 1996*

This value indicates the status of the licence key activation.

0 / No Function

If PLC receives this number from this ID, it is likely that the Micro Grid application is not loaded on the drive.

1 / No Code

Correct application in the drive, but the licence key has not been given.

2 / Code Given, not possible to verify, no connection to power unit

The licence key has been given, but there is no connection to power unit to verify it.

Charge the DC at least for 20 s.

NOTE! It is possible that the drive gives a licence fault in this state. Power up the power unit, so that the control board can read the drive serial number.

3 / Code Wrong

The code that was entered is wrong.

4 / Licence Key entered too many times

A wrong licence key has been entered three times. Power down the drive before trying to enter a new code.

5 / Code Accepted

The correct key has been entered, and all functions of Micro Grid application are available.

6 / Unknown Error

The licence key calculation has detected an internal error. Take the service information and the parameter file from the drive when the power unit is powered. Send these files to the technical support of the manufacturer (tech.supportVDF@vacon.com).

4.2.6 LINE MONITORING

V1.7.1 Line Voltage D7 *V ID 1650*

This is the same signal as *V1.1.12*. See chapter 4.2.1.

V1.7.2 Line Frequency D7 *Hz ID 1654*

This is the same signal as *V1.1.13*. See chapter 4.2.1.

V1.7.3 Line Voltage THD % ID 1670

Total Harmonic Distortion of the line voltage measurement when using the OPT-D7 option board in slot C.

V1.7.4 Line Voltage HF RMS V ID 1671

Root Mean Square value of high frequency components in the line voltage measurement when using the OPT-D7 option board in slot C.

5. PARAMETER LIST

In this chapter you will find the lists of parameters that are available in this application.

5.1 BASIC PARAMETERS

Table 2. Basic parameters, G2.1

Code	Parameter	Min	Max	Unit	Default	ID	Description
P2.1.1	Grid Nom Voltage	AFE: 500V: 380V 690V: 525V	AFE: 500V: 500V 690V: 690V	Vac	500V:400 690V:690	110	Set the nominal voltage of the grid. Island and uGrid can go down to 100 Vac. Set System Nominal DC P2.1.7
P2.1.2	Grid Nom. Frequency	0	320	Hz	50.00	1532	Micro Grid and Island mode: Grid Nominal Frequency AFE Mode: Initial start frequency.
P2.1.3	System Rated Current	0.0	lh	A	ll	113	Used to scale % values.
P2.1.4	System Cos Phi	0.10	1.00		0.80	120	
P2.1.5	System Rated kVA	0	32000	kVA	0	213	
P2.1.6	System Rated kW	0	32000	kW	0	116	
P2.1.7	System Nominal DC	500V: 436 690V: 602	500V: 675 690V: 931	Vdc	500V:675 690V:931	1805	Used for DC Voltage reference and for MCB close limit
P2.1.8	Parallel AFE	0	1		0	1501	0 = Single AFE 1 = Parallel AFE Activation will set DC Drooping to 3%.
P2.1.9	Transformer: Grid Converter Side U	0	3200	Vac	1000	1850	
P2.1.10	Transformer: Grid Side	0	3200	Vac	1000	1851	
P2.1.11	Transformer: Phase Shift	-360	360	Deg	0.0	1852	e.g. Dyn11 = 30.0 Degree
P2.1.12	Identification	0	1		0	631	1 = Current measurement offset

5.2 REFERENCE HANDLING

Table 3. Reference handling, G2.2

Code	Parameter	Min	Max	Unit	Default	ID	Description
P2.2.1	DC Voltage Ref.	500V: 105% 690V: 105%	500V: 797 Vdc 690V: 1099 Vdc	%	110.00	1462	DC Voltage reference as % of System Nominal DC.
P2.2.2	Reactive Current Reference	-170	170	%	0	1459	Regenerative reactive current reference 100.0 = System Rated Current. Positive = Inductive Negative = Capacitive

5.2.1 DC REFERENCE*Table 4. DC references, G2.2.3*

Code	Parameter	Min	Max	Unit	Default	ID	Description
P2.2.3.1	DC Voltage Drooping	0	100	%	0	620	AFE drooping DC-voltage.
P2.2.3.2	DC Voltage Reference Ramp Rate	0	10000	%/s	1000	1199	
P2.2.3.3	DC Voltage Reference Filtering time	0	15.00	s	0.00	1760	
P2.2.3.4	DC Reference Offset	-15	15	%	0,00	1776	

5.2.2 POWER / FREQUENCY REFERENCE*Table 5. Power / Frequency reference, G2.2.4*

Code	Parameter	Min	Max	Unit	Default	ID	Description
P2.2.4.1	Freq Droop Offset	-5.00	5.00	Hz	0.00	1791	
P2.2.4.2	Freq. Down	0.1	E.10	DigIn	0.1	417	
P2.2.4.3	Freq. Up	0.1	E.10	DigIn	0.1	418	
P2.2.4.4	Freq. Adjust Rate	0.001	20.00 0	Hz/s	0.100	331	
P2.2.4.5	Freq. Max Adjust	0.00	25.00	Hz	2.50	1558	
P2.2.4.6	Base Current Ref.	-170.0	170.0	%	0.0	1533	
P2.2.4.7	Base reference increase rate	0	10000	%/s	100	1536	
P2.2.4.8	Base Ref To Zero	0	3		0	1537	0 = No Action 1 = At Stop State 2 = When AFE 3 = Stop & AFE
P2.2.4.9	Base Reference At Stop	0	170.0	%	5.0	1538	
P2.2.4.10	FreqMotPotReset	0	3		1	367	0 = No Action 1 = At Stop State 2 = When AFE 3 = Stop & AFE

5.2.3 REFERENCE ADJUST*Table 6. Reference adjustment, G2.2.5*

Code	Parameter	Min	Max	Unit	Default	ID	Description
P2.2.5.1	Reactive Adjust Rate	0.0	1000.0	%/s	1.0	1557	
P2.2.5.2	Reactive Ref Up	0.1	E.10	DigIn	0.1	1553	
P2.2.5.3	Reactive Ref Down	0.1	E.10	DigIn	0.1	1554	
P2.2.5.4	MaxReactiveAdjust	0,0	100,0	%	25,0	1559	

5.2.4 AC VOLTAGE REFERENCE

Table 7. AC voltage reference, G2.2.6

Code	Parameter	Min	Max	Unit	Default	ID	Description
P2.2.6.1	Voltage at field weakening point	10.00	200.00	%	100.00	603	
P2.2.6.2	Field weakening point	8.00	320.00	Hz	45.00	602	
P2.2.6.3	Voltage Correction	-50	50	V	0	1790	
P2.2.6.4	Capacitor Size	0.0	100.0		5.0	1460	
P2.2.6.5	Inductor Size	0.0	100.0		11,5	1461	
P2.2.6.6	Inductor Losses	0.0	100.0		11,0	1465	
P2.2.6.7	Voltage Down	0.1	E.10	DigIn	0.1	1551	
P2.2.6.8	Voltage Up	0.1	E.10	DigIn	0.1	1550	
P2.2.6.9	Voltage Adjust Rate	0.0	1000.0	%/s	1.0	1555	
P2.2.6.10	Voltage Maximum Adjust	0	20	%	20	1639	
P2.2.6.11	Voltage MotPot Reset	0	1		0	1640	0 = No Action 1 = At Stop State
P2.2.6.12	Start Voltage Mode	0	2		1	1641	0 = Zero Q Start 1 = Drooping 2 = Keep Zero Q
P2.2.6.13	Reset Zero Q Delay	0,00	120,00		0,00	1642	0,00 = No Reset

5.3 RAMP CONTROL

Table 8. Ramp control, G2.3

Code	Parameter	Min	Max	Unit	Default	ID	Description
P2.3.1	Ramp Time	0.1	3200.0	s	25.0	103	2.00 Hz/s if Range 50 Hz
P2.3.2	Ramp Range	0.01	100.00	Hz	50.00	1980	

5.4 INPUT SIGNALS

5.4.1 BASIC SETTINGS

Table 9. Basic settings, G2.4.1

Code	Parameter	Min	Max	Unit	Default	ID	Description
P2.4.1.1	Start/Stop Logic	0	2		0	300	0 = Start-No Act 1 = RPuls-FPuls 2 = RPuls-RPuls
P2.4.1.2	Input Inversion	0	65535		4	1091	Inversion control of the input I/O signals. B0 = INV Open Contactor B1 = INV Ext. Fault 1 B2 = INV Ext. Fault 2 B3 = INV Enable CB Close

5.4.2 DIGITAL INPUTS

Table 10. Digital inputs, G2.4.2

Code	Parameter	Min	Max	Unit	Default	ID	Description
P2.4.2.1	Start Signal 1	0	E.10		A.1	403	
P2.4.2.2	Start Signal 2	0	E.10		0.1	404	
P2.4.2.3	Open MCB	0	E.10		0.1	1600	Forced open command
P2.4.2.4	CB Feed Back	0	E.10		0.1	1453	AFE MCB feedback (MCB 1)
P2.4.2.5	Fault Reset	0	E.10		0.1	414	
P2.4.2.6	Ext Fault 1	0	E.10		0.1	405	
P2.4.2.7	Ext Fault 2	0	E.10		0.2	406	
P2.4.2.8	Run Enable	0	E.10		0.2	407	
P2.4.2.9	NET Synchronisation	0	E.10		0.1	1602	
P2.4.2.10	NET Close Enabled	0	E.10		0.1	1705	Interlock for shore connection
P2.4.2.11	NET Close Request	0	E.10		0.1	1604	
P2.4.2.12	NET Contactor FB	0	E.10		0.1	1660	
P2.4.2.13	Forced AFE Mode	0	E.10		0.1	1540	Force mode to AFE
P2.4.2.14	Cooling Monitor	0	E.10		0.2	750	OK input from the cooling unit
P2.4.2.15	Use CB 2	0	E.10		0.1	1708	Second AFE contactor coming from second grid to have 2 different supplies
P2.4.2.16	CB 2 Status	0	E.10		0.1	1710	Feedback signal from second AFE contactor
P2.4.2.17	AFE Mode 2	0	E.10		0.1	1711	Only active when P2.11.1 is in 6/FRee select
P2.4.2.18	AFE Mode 3	0	E.10		0.1	1712	Only active when P2.1.1 is in 6/FRee select
P2.4.2.19	Quick Stop	0	E.10		0.2	1213	Stop and opens MCB
P2.4.2.20	LCL Temperature	0	E.10		0.2	1179	
P2.4.2.21	Synch to SG Grid	0	E.10		0.1	1897	
P2.4.2.22	RR Enable	0	E.10		0.2	1896	Disables final Run Command
P2.4.2.23	I/O Terminal Control	0	E.10		0.1	409	
P2.4.2.24	Keypad Control	0	E.10		0.1	410	
P2.4.2.25	Fieldbus Control	0	E.10		0.1	411	
P2.4.2.26	Enable MCB Close	0	E.10		0.2	1619	
P2.4.2.27	Reset P/Hz MotPot Adjust	0	E.10		0.1	1608	

5.4.3 ANALOGUE INPUT 1*Table 11. Analogue input 1, G2.4.3*

Code	Parameter	Min	Max	Unit	Default	ID	Description
P2.4.3.1	AI1 signal selection	0.1	E.10		0.1	377	
P2.4.3.2	AI1 filter time	0.000	32.000	s	0.000	324	
P2.4.3.3	AI1 custom minimum setting	-160.00	160.00	%	0.00	321	
P2.4.3.4	AI1 custom maximum setting	-160.00	160.00	%	100.00	322	
P2.4.3.5	AI1 signal inversion	0	1		0	387	
P2.4.3.6	AI1 reference scaling, minimum value	-32000	32000		0	303	
P2.4.3.7	AI1 reference scaling, maximum value	-32000	32000		0	304	
P2.4.3.8	AI1 Controlled ID	0	10000		0	1507	

5.4.4 ANALOGUE INPUT 2*Table 12. Analogue input 2, G2.4.4*

Code	Parameter	Min	Max	Unit	Default	ID	Description
P2.4.4.1	AI2 signal selection	0.1	E.10		0.1	388	
P2.4.4.2	AI2 filter time	0.000	32.000	s	0.000	329	
P2.4.4.3	AI2 custom minimum setting	-160.00	160.00	%	0.00	326	
P2.4.4.4	AI2 custom maximum setting	-160.00	160.00	%	100.00	327	
P2.4.4.5	AI2 signal inversion	0	1		0	398	
P2.4.4.6	AI2 reference scaling, minimum value	-32000	32000		0	393	
P2.4.3.7	AI2 reference scaling, maximum value	-32000	32000		0	394	
P2.4.4.8	AI2 Controlled ID	0	10000		0	1511	

5.4.5 ANALOGUE INPUT 3*Table 13. Analogue input 2, G2.4.5*

Code	Parameter	Min	Max	Unit	Default	ID	Description
P2.4.5.1	AI3 signal selection	0.1	E.10		0.1	141	
P2.4.5.2	AI3 filter time	0.000	32.000	s	0.000	142	
P2.4.5.3	AI3 custom minimum setting	-160.00	160.00	%	0.00	144	
P2.4.5.4	AI3 custom maximum setting	-160.00	160.00	%	100.00	145	
P2.4.5.5	AI3 signal inversion	0	1		0	151	
P2.4.5.6	AI3 reference scaling, minimum value	-32000	32000		0	1037	
P2.4.5.7	AI3 reference scaling, maximum value	-32000	32000		0	1038	
P2.4.5.8	AI3 Controlled ID	0	10000		0	1509	

5.4.6 ANALOGUE INPUT 4

Table 14. Analogue input 2, G2.4.4

Code	Parameter	Min	Max	Unit	Default	ID	Description
P2.4.6.1	AI4 signal selection	0.1	E.10		0.1	152	
P2.4.6.2	AI4 filter time	0.000	32.000	s	0.000	153	
P2.4.6.3	AI4 custom minimum setting	-160.00	160.00	%	0.00	155	
P2.4.6.4	AI4 custom maximum setting	-160.00	160.00	%	100.00	156	
P2.4.6.5	AI4 signal inversion	0	1		0	162	
P2.4.6.6	AI4 reference scaling, minimum value	-32000	32000		0	1039	
P2.4.6.7	AI4 reference scaling, maximum value	-32000	32000		0	1040	
P2.4.6.8	AI4 Controlled ID	0	10000		0	1510	

5.5 OUTPUT SIGNALS

5.5.1 DIGITAL OUTPUT SIGNALS

Table 15. Digital output signals, G2.5.1

Code	Parameter	Min	Max	Unit	Default	ID	Description
P2.5.1.1	MCB1 Close Control	0.1	E.10		0.1	1218	AFE contactor, fixed to relay output B.2
P2.5.1.2	MCB1 Open Control	0.1	E.10		0.1	1219	
P2.5.1.3	Ready	0.1	E.10		0.1	432	The AC drive is ready to operate.
P2.5.1.4	Run	0.1	E.10		0.1	433	The AC drive operates (the motor is running).
P2.5.1.5	Common Fault	0.1	E.10		0.1	434	A fault trip has occurred.
P2.5.1.6	Fault, Inverted	0.1	E.10		0.1	435	No fault trip has occurred.
P2.5.1.7	At reference	0.1	E.10		0.1	442	
P2.5.1.8	Overtemperature Warn.	0.1	E.10		0.1	439	The heatsink temperature exceeds +70 °C
P2.5.1.9	Warning	0.1	E.10		0.1	436	General warning signal.
P2.5.1.10	CB2 Close Control	0.1	E.10		0.1	1709	Second AFE contactor control
P2.5.1.11	NET Contactor	0.1	E.10		0.1	1605	NET contactor (DC)
P2.5.1.12	D7 Synchronized	0.1	E.10		0.1	1753	Drive is synchronised to D7 card
P2.5.1.13	Charge Control	0.1	E.10		0.1	1568	Charge control from start command
P2.5.1.14	Common Alarm	0.1	E.10		0.1	1684	
P2.5.1.15	Ready For Start	0.1	E.10		0.1	1686	No conditions that could disable starting active
P2.5.1.16	Quick Stop Active	0.1	E.10		0.1	1687	
P2.5.1.17	Fieldbus digital input 1	0.1	0.1		0.1	455	FB CW B11
P2.5.1.18	FB Dig 1 Parameter	ID0	ID0			891	Select parameter to control
P2.5.1.19	Fieldbus digital input 2	0.1	0.1		0.1	456	FB CW B12
P2.5.1.20	FB Dig 2 Parameter	ID0	ID0			892	Select parameter to control
P2.5.1.21	Fieldbus digital input 3	0.1	0.1		0.1	457	FB CW B13
P2.5.1.22	FB Dig 3 Parameter	ID0	ID0			893	Select parameter to control
P2.5.1.23	Fieldbus digital input 4	0.1	0.1		0.1	169	FB CW B14
P2.5.1.24	FB Dig 4 Parameter	ID0	ID0			894	Select parameter to control

5.5.2 DELAYED DO 1

Table 16. Delayed digital output 1, G2.5.2

Code	Parameter	Min	Max	Unit	Default	ID	Description
P2.5.2.1	Dig.Out 1 Signal	0.1	E.10		0.1	486	Connect the delayed DO1 signal to the digital output of your choice with this parameter.
P2.5.2.2	DO1 Content	0	10		0	312	0 = Not used 1 = Ready 2 = Run 3 = Fault 4 = Fault inverted 5 = FC overheat warning 6 = Ext. fault or warning 7 = Ref. fault or warning 8 = Warning 9 = Reverse 10 = SynchronisedToD7 11 = Start Command given 12 = FB DIN2 13 = FB DIN3 14 = ID.Bit DO
P2.5.2.3	DO1 ON Delay	0.00	320.00	s	0.00	487	0.00 = On delay not in use
P2.5.2.4	DO1 OFF Delay	0.00	320.00	s	0.00	488	0.00 = On delay not in use
P2.5.2.5	ID.Bit Free DO	0.00	2000.00	ID.Bit	0.00	1216	

5.5.3 DELAYED DO 2

Table 17. Delayed digital output 2, G2.5.3

Code	Parameter	Min	Max	Unit	Default	ID	Description
P2.5.3.1	Dig.Out 2 Signal	0.1	E.10		0.1	486	Connect the delayed DO2 signal to the digital output of your choice with this parameter.
P2.5.3.2	DO2 Content	0	10		0	312	0 = Not used 1 = Ready 2 = Run 3 = Fault 4 = Fault inverted 5 = FC overheat warning 6 = Ext. fault or warning 7 = Ref. fault or warning 8 = Warning 9 = Reverse 10 = SynchronisedToD7 11 = Start Command given 12 = FB DIN2 13 = FB DIN3 14 = ID.Bit DO
P2.5.3.3	DO2 ON Delay	0.00	320.00	S	0.00	487	0.00 = On delay not in use
P2.5.3.4	DO2 OFF Delay	0.00	320.00	S	0.00	488	0.00 = On delay not in use
P2.5.2.5	ID.Bit Free DO	0.00	2000.00	ID.Bit	0.00	1217	

5.5.4 ANALOGUE OUTPUT 1

Table 18. Analogue output signal 1, G2.5.4

Code	Parameter	Min	Max	Unit	Default	ID	Description
P2.5.4.1	lout 1 signal	AnOUT:0.1	AnOUT:E.10		AnOUT:A.1	464	Connect the A01 signal to the analogue output of your choice with this parameter.
P2.5.4.2	lout Content	0	11		1 / O/P Freq	307	0 = Not used 1 = DC Voltage 2 = Drive Current 3 = Output Voltage 4 = Active Current 5 = Power 6 = Reactive Current 7 = Power Bidirectional 8 = AI1 9 = AI2 10 = FB Analogue Output 11 = Line Voltage 12 = FreqOut, bidirectional 13 = Value Control Out
P2.5.4.3	lout Filter Time	0	10	s	1	308	0 = No filtering
P2.5.4.4	lout Invert	0	1		0 / No Inversion	309	0 = Not inverted 1 = Inverted
P2.5.4.5	lout Minimum	0	1		0 / 0 mA	310	0 = 0 mA 1 = 4 mA
P2.5.4.6	lout Scale	10	1000	%	100	311	Percentage multiplier. Defines output when content is in maximum value
P2.5.4.7	lout Offset	-100	100	%	0	375	Add -1000 to 1000% to the analogue output.

5.5.5 ANALOGUE OUTPUT 2

Table 19. Analogue output signal 2, G2.5.5

Code	Parameter	Min	Max	Unit	Default	ID	Description
P2.5.5.1	lout 2 signal	AnOUT:0.1	AnOUT:E.10		AnOUT:A.1	464	Connect the AO1 signal to the analogue output of your choice with this parameter.
P2.5.5.2	lout Content	0	11		1 / O/P Freq	307	0 = Not used 1 = DC Voltage 2 = Drive Current 3 = Output Voltage 4 = Active Current 5 = Power 6 = Reactive Current 7 = Power Bidirectional 8 = AI1 9 = AI2 10 = FB Analogue Output 11 = Line Voltage 12 = FreqOut, bidirectional 13 = Value Control Out
P2.5.5.3	lout Filter Time	0	10	s	1	308	0 = No filtering
P2.5.5.4	lout Invert	0	1		0 / No Inversion	309	0 = Not inverted 1 = Inverted
P2.5.5.5	lout Minimum	0	1		0 / 0 mA	310	0 = 0 mA 1 = 4 mA
P2.5.5.6	lout Scale	10	1000	%	100	311	Percentage multiplier. Defines output when content is in maximum value
P2.5.5.7	lout Offset	-100	100	%	0	375	Add -1000 to 1000% to the analogue output.

5.5.6 ANALOGUE OUTPUT 3

Table 20. Analogue output signal 3, G2.5.6

Code	Parameter	Min	Max	Unit	Default	ID	Description
P2.5.6.1	lout 3 signal	AnOUT:0.1	AnOUT:E.10		AnOUT:A.1	464	Connect the AO1 signal to the analogue output of your choice with this parameter.
P2.5.6.2	lout Content	0	11		1	307	0 = Not used 1 = DC Voltage 2 = Drive Current 3 = Output Voltage 4 = Active Current 5 = Power 6 = Reactive Current 7 = Power Bidirectional 8 = AI1 9 = AI2 10 = FB Analogue Output 11 = Line Voltage 12 = FreqOut, bidirectional 13 = Value Control Out
P2.5.6.3	lout Filter Time	0	10	s	1	308	0 = No filtering
P2.5.6.4	lout Invert	0	1		0 / No Inversion	309	0 = Not inverted 1 = Inverted
P2.5.6.5	lout Minimum	0	1		0 / 0 mA	310	0 = 0 mA 1 = 4 mA
P2.5.6.6	lout Scale	10	1000	%	100	311	Percentage multiplier. Defines output when content is in maximum value
P2.5.6.7	lout Offset	-100	100	%	0	375	Add -1000 to 1000% to the analogue output.

5.5.7 OPTIONS

Table 21. Output signal options, G2.5.7

Code	Parameter	Min	Max	Unit	Default	ID	Description
P2.5.7.1	Output Inversion	0	65535		0	1806	
P2.5.7.2	Freq Scale Min AO	0.00	320.00	Hz	0.00	1809	
P2.5.7.3	Freq Scale Max AO	0.00	320.00	Hz	50.00	1808	
P2.5.7.4	DC Supervision Limit	0	1500	V		1454	
P2.5.7.5	MCB Close Mode	0	3		0	1607	0 = DC Voltage 1 = DC or Start command 2 = Start Command. 3 = DC, Start or Pre-Charge
P2.5.7.6	MCB At Stop Command	0	1		0	1685	0 = Keep CB Closed 1 = Open CB
P2.5.7.7	MCB Close Delay	0.00	3.00		0.00	1513	Delay to CB RO

5.6 LIMIT SETTINGS

5.6.1 CURRENT LIMIT

Table 22. Current limit settings, G2.6.1

Code	Parameter	Min	Max	Unit	Default	ID	Description
P2.6.1.1	Current Limit	0	Varies	A	Varies	107	Total current limit
P2.6.1.2	Short Circuit Level	0	800,1	%	800.0	1620	Disabled above 499.0%
P2.6.1.3	Short Circuit Time	0	5000	ms	0	1515	
P2.6.1.4	High Freq. Current Limit	0	1		0	1517	0 = Enabled (FR) 1 = Disabled (INU)
P2.6.1.5	SC Voltage Limit	0.00	150.00	%	80.00	1518	
P2.6.1.6	Output Active Current Limit	0	300	%	300	1290	Generating Active Current limit in AFE mode to grid.
P2.6.1.7	Input Active Current Limit	0	300	%	300	1289	Motoring Active Current limit in AFE mode to DC.
P2.6.1.8	Over Current Trip Limit	0	1000	%	0,0	1094	Software over current trip limit F1 S4. 0 = Disabled.

5.6.2 POWER LIMIT

Table 23. Power limit settings, G2.6.2

Code	Parameter	Min	Max	Unit	Default	ID	Description
P2.6.2.1	Output Power Limit	0,0	300,0	%	300,0	1288	
P2.6.2.2	Input Power Limit	0,0	300,0	%	300,0	1287	
P2.6.2.3	Limit increase Rate	0	10000	%/s	100	1502	
P2.6.2.4	High Frequency Power Limit	0.00	100.00	Hz	0.00	1703	0.00 = Not Used.

5.6.3 FREQUENCY LIMIT

Table 24. Frequency limit settings, G2.6.3

Code	Parameter	Min	Max	Unit	Default	ID	Description
P2.6.3.1	Line High Trip Limit	0.00	120.00	Hz	75.00	1716	F10 immediately if above
P2.6.3.2	Line Low Trip Limit	0.00	120.00	Hz	25.00	1717	F10 immediately if below

5.6.4 MICRO GRID

Table 25. Micro grid limit settings, G2.6.4

Code	Parameter	Min	Max	Unit	Default	ID	Description
P2.6.4.1	Current limit Min	-300.0	0.0	%		1621	Island and uGrid mode
P2.6.4.2	Current limit Max	0.0	300.0	%		1622	Island and uGrid mode
P2.6.4.3	Max Limit Increase rate	0	10000	%/s		1502	
P2.6.4.4	Current limit Kp	0	1000			1623	
P2.6.4.5	Current Limit ti	0	1000	ms		1625	
P2.6.4.6	Current Limit Max Minimum	0.0	10.0	%		1890	
P2.6.4.7	Current Limit To Zero Mode	0	10			1539	0 = No Action 1 = At Stop State

5.6.5 DC VOLTAGE*Table 26. DC voltage limit settings, G2.6.5*

Code	Parameter	Min	Max	Unit	Default	ID	Description
P2.6.5.1	Under Voltage Limit	0.00	320.00	%	65.00	1524	
P2.6.5.2	Over voltage limit	0.00	320.00	%	120.00	1523	

5.7 DRIVE CONTROL*Table 27. Drive control, G2.7*

Code	Parameter	Min	Max	Unit	Default	ID	Description
P 2.7.1	Switching Freq	3.6	6	kHz	3.6	601	
P 2.7.2	AFE Options 1	0	65535		544	1463	
P 2.7.3	AFE Options 2	0	65535		0	1464	
P 2.7.4	AFE Options 3	0	65535		0	1466	
P 2.7.5	Start Delay	0.10	3200	s	1.00	1500	
P 2.7.6	Modulator Type	0	4		1	1516	
P 2.7.7	Control Options 1	0	65535		0	1707	
P 2.7.8	Control Options 2	0	65535		0	1798	
P 2.7.9	Operation Time	0	2^32		0	1855	

5.7.1 AFE CONTROL*Table 28. AFE control, G2.7.10*

Code	Parameter	Min	Max	Unit	Default	ID	Description
P2.7.10.1	Dynamic Support Kp	0	32000		0	1797	
P2.7.10.2	Synch Kp	0	32000		2000	1457	
P2.7.10.3	Synch Ti	0	1000		50	1458	
P2.7.10.4	Active Current Kp	0	4000		400	1455	
P2.7.10.5	Active Current Ti	0,0	100,0		1,5	1456	
P2.7.10.6	Synch. Kp Start	0	10000		4000	1300	
P2.7.10.7	Voltage Ctrl Kp	0	32000		200	1451	
P2.7.10.8	Voltage Ctrl Ti	0	1000	ms	50	1452	

5.8 PROTECTIONS

5.8.1 GENERAL

Table 29. General protection settings, G2.9.1

Code	Parameter	Min	Max	Unit	Default	ID	Description
P2.9.1.1	Thermistor Fault Response	0	3		2 / Fault	732	0 = No response 1 = Warning 2 = Fault, stop acc. stop mode 3 = Fault, stop by coasting
P2.9.1.2	Overtemperature Response	2	5		2 / Fault	1757	As Par. P2.9.1.4
P2.9.1.3	Overvoltage Response	2	5		2 / Fault	1755	As Par. P2.9.1.4
P2.9.1.4	Cooling Flt. Delay	0	7	s	2	751	
P2.9.1.5	LCL Overtemperature	0	3		2	1505	
P2.9.1.6	Max Charge Time	0.00	30.00	s	5.00	1522	Charging time limit when drive charging options are used.
P2.9.1.7	MCB At Fault	0	1		0	1699	0 = No Action 1 = Open MCB
P2.9.1.8	Start Fault Delay	0.00	320.00	s	3.00	1512	
P2.9.1.9	Quick Stop Response	1	2		1 / Warning	1758	1 = Warning 2 = Fault
P2.9.1.10	Reactive Error Trip Limit	-300	300	%	7.5	1759	
P2.9.1.11	MCB Fault Delay	0.00	10.00	s	3.50	1521	
P2.9.1.12	Line Phase Supervision	0	2		0 / No Action	702	0 = No Action 1 = Warning 2 = Fault
P2.9.1.13	4 mA Fault Response	0	2		0 / No Action	700	0 = No Action 1 = Warning 2 = Fault
P2.9.1.14	Reactive Current Limit Response	0	2		1 / Warning	1981	0 = No Action 1 = Warning 2 = Fault
P2.9.1.15	FaultWarnIndicat	0	2		1		0=Static 1=Toggle 2=Marine

5.8.2 TEMPERATURE SENSOR PROTECTIONS

Table 30. Temperature sensor protection settings, 2.9.2

Code	Parameter	Min	Max	Unit	Default	Cust	ID	Note
P2.9.2.1	No. of used inputs on board 1	0	5		0		739	0=Not used (ID Write) 1 = Sensor 1 in use 2 = Sensor 1 & 2 in use 3 = Sensor 1 & 2 & 3 in use 4 = Sensor 2 & 3 in use 5 = Sensor 3 in use
P2.9.2.2	Response to temperature fault	0	3		2		740	0=No response 1=Warning 2=Fault,stop acc. to 2.3.2 3=Fault,stop by coasting
P2.9.2.3	Board 1 warning limit	-30.0	200.0	C°	120.0		741	
P2.9.2.4	Board 1 fault limit	-30.0	200.0	C°	130.0		742	
P2.9.2.5	No. of uses inputs on board 2	0	5		0		743	0=Not used (ID Write) 1 = Sensor 1 in use 2 = Sensor 1 & 2 in use 3 = Sensor 1 & 2 & 3 in use 4 = Sensor 2 & 3 in use 5 = Sensor 3 in use
P2.9.2.6	Response to temperature fault	0	3		2		766	0=No response 1=Warning 2=Fault,stop acc. to 2.3.2 3=Fault,stop by coasting
P2.9.2.7	Board 2 warning limit	-30.0	200.0	C°	120.0		745	
P2.9.2.8	Board 2 fault limit	-30.0	200.0	C°	130.0		746	
P2.9.2.9.1	Channel 1B Warn	-30.0	200.0	C°	0.0		764	
P2.9.2.9.2	Channel 1B Fault	-30.0	200.0	C°	0.0		765	
P2.9.2.9.3	Channel 1C Warn	-30.0	200.0	C°	0.0		768	
P2.9.2.9.4	Channel 1C Fault	-30.0	200.0	C°	0.0		769	
P2.9.2.9.5	Channel 2B Warn	-30.0	200.0	C°	0.0		770	
P2.9.2.9.6	Channel 2B Fault	-30.0	200.0	C°	0.0		771	
P2.9.2.9.7	Channel 2C Warn	-30.0	200.0	C°	0.0		772	
P2.9.2.9.8	Channel 2C Fault	-30.0	200.0	C°	0.0		773	

5.8.3 EARTH FAULT

Table 31. Earth fault protection settings, G2.9.3

Code	Parameter	Min	Max	Unit	Default	ID	Description
P2.9.3.1	Earth Fault Response	2	5		2 / Fault	1756	
P2.9.3.2	Earth Fault Level	0	100	%	50	1333	

5.8.4 FIELD BUS FAULT

Table 32. Fieldbus protection settings, G2.9.4

Code	Parameter	Min	Max	Unit	Default	ID	Description
P2.9.4.1	FB Fault response Slot D	0	6		2	733	
P2.9.4.2	FB Fault response Slot E	0	6		2	761	
P2.9.4.3	FB WD Time	0.00	30.00	s	0.00	1354	

5.8.5 EXTERNAL FAULT*Table 33. External fault settings, G2.9.5*

Code	Parameter	Min	Max	Unit	Default	ID	Description
P2.9.5.1	External Fault 1	0	3		2 / Fault	701	
P2.9.5.2	External Fault 2	0	3		1 / Warning	1504	
P2.9.5.3	External Fault Delay	0.00	320.00	s	0.00	1506	

5.8.6 GRID VOLTAGE D7*Table 34. Grid voltage protections settings, G2.9.6*

Code	Parameter	Min	Max	Unit	Default	ID	Description
P2.9.6.1	Voltage D7 Response	0	2		1	1626	
P2.9.6.2	Voltage Low Warning Limit	0.00	320.00	%	90.00	1893	
P2.9.6.3	Voltage Low Trip Limit	0.00	320.00	%	80.00	1899	
P2.9.6.4	Voltage High Warning Limit	0.00	320.00	%	110.00	1895	
P2.9.6.5	Voltage High Trip Limit	0.00	320.00	%	115.00	1799	
P2.9.6.6	Voltage Trip Delay	0.00	320.00	s	0.50	1898	

5.8.7 GRID FREQUENCY*Table 35. Grid frequency protections settings, G2.9.7*

Code	Parameter	Min	Max	Unit	Default	ID	Description
P2.9.7.1	Freq. Supply Response	0	2		2	1627	
P2.9.7.2	Freq. D7 Response	0	2		1	1628	
P2.9.7.3	Freq. Low Warning Limit	0.00	320.00	%	95.00	1780	Low limit for e.g. Mot Pot function
P2.9.7.4	Freq. Low Trip Limit	0.00	320.00	%	90.00	1781	
P2.9.7.5	Freq. High Warning Limit	0.00	320.00	%	106.00	1783	High limit for e.g. Mot Pot function.
P2.9.7.6	Freq. High Trip Limit	0.00	320.00	%	110.00	1784	
P2.9.7.7	Freq. Trip Delay	0.00	320.00	s	0.50	1785	

5.8.8 VOLTAGE*Table 36. Supply voltage protection settings, G2.9.8*

Code	Parameter	Min	Max	Unit	Default	ID	Description
P2.9.8.1	Voltage Supply Response	0	2		2	1629	
P2.9.8.2	Voltage Low Trip Limit	0.00	320.00	%	75.00	1891	
P2.9.8.3	Voltage Low Warning Limit	0.00	320.00	%	90.00	1880	
P2.9.8.4	Voltage High Warning Limit	0.00	320.00	%	120.00	1881	
P2.9.8.5	Voltage High Trip Limit	0.00	320.00	%	130.00	1992	

5.8.9 OVER LOAD*Table 37. Over load protection settings, G2.9.9*

Code	Parameter	Min	Max	Unit	Default	ID	Description
P2.9.9.1	Over Load Response	0	2		1	1838	0=No response 1=Warning 2=Fault
P2.9.9.2	Over Load Signal	0	2		0	1837	0=Not Used 1=Current % 2=Active Current 3=Reactive Current
P2.9.9.3	Over Load Maximum Input	0,0	300,0	%	150,0	1839	
P2.9.9.4	Over Load maximum Step	0	10000		200	1840	

5.8.10 D7 PROTECTIONS

Table 38. D7protection settings, G2.9.10

Code	Parameter	Min	Max	Unit	Default	ID	Description
P2.9.10.1	THD response	0	2		0	1672	0=No Action 1=Warning 2=Fault
P2.9.10.2	THD warning limit	0	5000	%	600	1673	
P2.9.10.3	THD fault limit	0	5000	%	1000	1674	
P2.9.10.4	HF RMS response	0	2		0	1675	0=No Action 1=Warning 2=Fault
P2.9.10.5	HF RMS warning limit	0	4000	V	200	1676	
P2.9.10.6	HF RMS fault limit	0	4000	V	600	1677	

5.8.11 EXTRA

Table 39. Extra protection settings, G2.9

Code	Parameter	Min	Max	Unit	Default	ID	Description
P2.9.11	Fault Simulation	0	65535		0	1569	
P2.9.12	Reset datalogger	0	1		0	1857	

5.9 FIELDBUS

Table 40. Fieldbus settings, G2.10

Code	Parameter	Min	Max	Unit	Default	ID	Description
P2.10.1	FB Actual Value Sel	0	10000		44	1853	
P2.10.2	FB Data Out1 Sel	0	10000		1104	852	
P2.10.3	FB Data Out2 Sel	0	10000		1508	853	
P2.10.4	FB Data Out3 Sel	0	10000		1172	854	
P2.10.5	FB Data Out4 Sel	0	10000		1173	855	
P2.10.6	FB Data Out5 Sel	0	10000		56	856	
P2.10.7	FB Data Out6 Sel	0	10000		1174	857	
P2.10.8	FB Data Out7 Sel	0	10000		1125	858	
P2.10.9	FB Data Out8 Sel	0	10000		1157	859	
P2.10.10	FB Data Out9 Sel	0	10000		0	558	Data Out 9-16 visible only with correct HW and SW.
P2.10.11	FB Data Out10 Sel	0	10000		0	559	
P2.10.12	FB Data Out11 Sel	0	10000		0	560	
P2.10.13	FB Data Out12 Sel	0	10000		0	561	

Code	Parameter	Min	Max	Unit	Default	ID	Description
P2.10.14	FB Data Out13 Sel	0	10000		0	562	
P2.10.15	FB Data Out14 Sel	0	10000		0	563	
P2.10.16	FB Data Out15 Sel	0	10000		0	564	
P2.10.17	FB Data Out16 Sel	0	10000		0	565	
P2.10.18	FB Data In 1 Sel	0	10000		0	876	
P2.10.19	FB Data In 2 Sel	0	10000		0	877	
P2.10.20	FB Data In 3 Sel	0	10000		0	878	
P2.10.21	FB Data In 4 Sel	0	10000		0	879	
P2.10.22	FB Data In 5 Sel	0	10000		0	880	
P2.10.23	FB Data In 6 Sel	0	10000		0	881	
P2.10.24	FB Data In 7 Sel	0	10000		0	882	
P2.10.25	FB Data In 8 Sel	0	10000		0	883	
P2.10.26	FB Data In 9 Sel	0	10000		0	550	Data In 9-16 visible only with correct HW and SW.
P2.10.27	FB Data In 10 Sel	0	10000		0	551	
P2.10.28	FB Data In 11 Sel	0	10000		0	552	
P2.10.39	FB Data In 12 Sel	0	10000		0	553	
P2.10.30	FB Data In 13 Sel	0	10000		0	554	
P2.10.31	FB Data In 14 Sel	0	10000		0	555	
P2.10.32	FB Data In 15 Sel	0	10000		0	556	
P2.10.33	FB Data In 16 Sel	0	10000		0	557	
P2.10.34	GSW Data	0	10000		68	897	
P2.10.35	State Machine	0	3		2	896	0 = Basic 1 = Standard 2 = Vacon AFE 1 3 = Vacon AFE 2
P2.10.36	FB Ref Min	105.00	320.00	%	105.00	850	
P2.10.37	FB Ref Max	105.00	320.00	%	130.00	851	
P2.10.38	Control Slot Selector	0	Varies		0	1440	0=Not Sel., 4=Slot D, 5=Slot E, 6=Slot D Fast, 7=Slot E Fast, 8=Slot D 16 PD, 9=Slot E 16 PD Note: Options 6-9 visible only with correct HW and SW.
P2.10.39	SW B11 ID.Bit	0.00	2000.15		0.00	1907	
P2.10.40	SW B12 ID.Bit	0.00	2000.15		0.00	1908	
P2.10.41	SW B13 ID.Bit	0.00	2000.15		0.00	1909	
P2.10.42	SW B14 ID.Bit	0.00	2000.15		0.00	1910	
P2.10.43	uCW B12	0	10000		0	1934	
P2.10.44	uCW B13	0	10000		0	1935	
P2.10.45	uCW B14	0	10000		0	1936	
P2.10.46	uCW B15	0	10000		0	1937	

5.10 MICRO GRID*Table 41. Micro Grid, G2.11*

Code	Parameter	Min	Max	Unit	Default	ID	Description
P2.11.1	Control Mode	0	6		0 / AFE	1531	0 = AFE 1 = Island 2 = Micro Grid 3 = Island-AFE 4 = Island-Micro Grid 5 = Island-Micro Grid (Reserved) 6 = FreeSelect
P2.11.2	Frequency Droop	1	32	Hz	1	1534	
P2.11.3	Voltage Droop	0	320	%	10	1535	Reactive current drooping in percentage of P2.1.
P2.11.4	Start Power Mode	0	2		2	1503	0 = Zero power D7 1 = Zero Power F/O 2 = Drooping 3 = Isochron.Gen
P2.11.5	Voltage Rise Time	0	10000	ms	100	1541	
P2.11.6	Generator Mechanical Time Constant	0	32000	ms	0	1722	0 = Not used 1 >= Active Use 1000 ms as a starting point.
P2.11.7	Generator Speed Control Kp	0,0	3200,0	%/Hz	40,0	1723	
P2.11.8	Generator Speed Control Yi	0	32000	ms	32000	1724	

5.10.1 FREE SELECT*Table 42. Micro Grid free select settings, G2.11.9*

Code	Parameter	Min	Max	Unit	Default	ID	Description
P2.11.9.1	AFE Mode 1	0	6		0 / AFE	1616	
P2.11.9.2	AFE Mode 2	0	6		1 / Island	1617	
P2.11.9.3	AFE Mode 3	0	6		2 / Micro Grid	1713	

5.11 SYNCHRONISATION TO EXTERNAL GRID

Table 43. Synchronization to external grid settings, G2.12

Code	Parameter	Min	Max	Unit	Default	ID	Description
P2.12.1	Synch. Offset	-3172	3171		0	1601	Used to compensate for transformer angle offset. (3172 equals 180 degrees offset).
P2.12.2	Synch Reference	-3170	3170		0	1611	Gives synchronisation point for synch error.
P2.12.3	Synch Kp	0	32000		500	1612	
P2.12.4	Synch Ti	0	32000		0	1613	
P2.12.5	Synch. Hysteresis	-3170	3170		50	1614	
P2.12.6	Contactor Delay	0	1000	ms	0	1624	In case no feedback from shore contactor, this can be used to simulate feedback signal.
P2.12.7	Synch Stop Mode	0	1		0 / Stay Run	1618	When stop is selected, drive will go to stop mode when feedback from shore contactor.

5.12 SYNCHRONISATION TO SHAFT GENERATOR

Table 44. Synchronization to shaft generator settings, G2.13

Code	Parameter	Min	Max	Unit	Default	ID	Description
P2.13.1	SG Follower Ramp Time	1.0	600.0	s	3.0	1527	
P2.13.2	SG Grid Phase Offset	-3200	3200		0	1586	
P2.13.3	Synch Gain	0	10.00	Hz	0.50	1778	
P2.13.4	Phase Synch Ramp Time	0.00	10.00	S	0.02	1777	
P2.13.5	Max Synch Correct	0	3200		3000	1992	
P2.13.6	Ramp Change Hysteresis	0	3070		3000	1894	

5.13 ID CONTROL FUNCTIONS

5.13.1 VALUE CONTROL

Table 45. Power reference input signal selection, G2.14.1

Code	Parameter	Min	Max	Unit	Default	Cust	ID	Description
P2.14.1.1	Control Input Signal ID	0	10000	ID	0		1580	
P2.14.1.2	Control Input Off Limit	-32000	32000		0		1581	
P2.14.1.3	Control Input On Limit	-32000	32000		0		1582	
P2.14.1.4	Control Output Off Value	-32000	32000		0		1583	
P2.14.1.5	Control Output On Value	-32000	32000		0		1584	
P2.14.1.6	Control Output Signal ID	0	10000	ID	0		1585	
P2.14.1.7	Control Mode	0	5		0		1586	0 = SR ABS 1 = Scale ABS 2 = Scale INV ABS 3 = SR 4 = Scale 5 = Scale INV
P2.14.1.8	Control Output Filtering rime	0.000	32.000	s	0.000		1721	

5.13.2 DIN ID CONTROL 1

Table 46. DIN ID control parameters, G2.14.2

Code	Parameter	Min	Max	Unit	Default	Cust	ID	Description
P2.14.2.1	ID Control DIN	0.1	E.10		0.1		1570	Slot Board input No. If 0.1 ID61 can be controlled from FB
P2.14.2.2	Controlled ID	0	10000	ID	0		1571	Select ID that is controlled by digital input
P2.14.2.3	False value	-32000	32000		0		1572	Value when DI is low
P2.14.2.4	True value	-32000	32000		0		1573	Value when DI is high

5.13.3 DIN ID CONTROL 2

Table 47. DIN ID control parameters, G2.14.3

Code	Parameter	Min	Max	Unit	Default	Cust	ID	Description
P2.14.3.1	ID Control DIN	0.1	E.10		0.1		1574	Slot Board input No. If 0.1 ID61 can be controlled from FB
P2.14.3.2	Controlled ID	0	10000	ID	0		1575	Select ID that is controlled by digital input
P2.14.3.3	False value	-32000	32000		0		1592	Value when DI is low
P2.14.3.4	True value	-32000	32000		0		1593	Value when DI is high

5.13.4 DIN ID CONTROL 3*Table 48. DIN ID control parameters, G2.14.4*

Code	Parameter	Min	Max	Unit	Default	Cust	ID	Description
P2.14.4.1	ID Control DIN	0.1	E.10		0.1		1578	Slot Board input No. If 0.1 ID61 can be controlled from FB
P2.14.4.2	Controlled ID	0	10000	ID	0		1579	Select ID that is controlled by digital input
P2.14.4.3	False value	-32000	32000		0		1594	Value when DI is low
P2.14.4.4	True value	-32000	32000		0		1596	Value when DI is high

5.13.5 DIN ID CONTROL 4*Table 49. DIN ID control parameters, G2.14.5*

Code	Parameter	Min	Max	Unit	Default	Cust	ID	Description
P2.14.5.1	ID Control DIN	0.1	E.10		0.1		1930	Slot Board input No. If 0.1 ID61 can be controlled from FB
P2.14.5.2	Controlled ID	0	10000	ID	0		1931	Select ID that is controlled by digital input
P2.14.5.3	False value	-32000	32000		0		1932	Value when DI is low
P2.14.5.4	True value	-32000	32000		0		1933	Value when DI is high

5.13.6 SIGNAL FAULT FUNCTION*Table 50. DIN ID control parameters, G2.14.5*

Code	Parameter	Min	Max	Unit	Default	Cust	ID	Description
P2.14.6.1	Fault Signal ID	0	10000	ID	0		1941	Signal to be monitored
P2.14.6.2	Fault Mode	0	2		0		1942	
P2.14.6.3	High Fault Limit	-32000	32000		32000		1943	
P2.14.6.4	Low Fault Limit	-32000	32000		-32000		1944	

5.14 AUTO RESET*Table 51. Auto reset parameters, G2.15*

Code	Parameter	Min	Max	Unit	Default	ID	Description
P2.15.1	Wait Time	0.00	60.00	s	5.00	717	
P2.15.2	Trial Time	0.00	120.00	s	30.00	718	
P2.15.3	Over voltage tries	0	3		0	721	
P2.15.4	Over current tries	0	3		0	722	
P2.15.6	External fault tries	0	10		0	725	

5.15 GRID VOLTAGE PI*Table 52. Grid voltage PI function parameters, G2.16*

Code	Parameter	Min	Max	Unit	Default	Cust	ID	Description
P2.16.1	PID Activation	0.1	E.10	DigIn	0.1		1807	Digital input to activate PI controller
P2.16.2	PI controller gain	0.0	1000.0	%	200.0		118	PI controller gain
P2.16.3	PI controller I-time	0.00	320.00	s	0.05		119	PI controller I-time

P2.16.4	PI Max Adjust	-32000	32000	%	5.00		360	PI High limit
P2.16.5.1	PI Frequency Low Limit	0.00	320.00	%	95.00		1630	
P2.16.5.2	PI Frequency High Limit	0.00	320.00	%	102.00		1631	
P2.16.5.3	PI Voltage Low Limit	0.00	320.00	%	90.00		1632	
P2.16.5.4	PI Voltage High Limit	0.00	320.00	%	110.00		1633	

5.16 KEYPAD CONTROL (CONTROL PANEL: MENU M3)

Table 53. Keypad control parameters M3

Code	Parameter	Default	Min	Max	Unit	ID	Description
P3.1	Control Place	2	0	2		1403	0 = PC Control 1 = I/O terminal 2 = Keypad (Default) 3 = Fieldbus 4 = SystemBus
P3.2	Licence Key	0	0			1995	

5.17 SYSTEM MENU (CONTROL PANEL: MENU M6)

For the parameters and functions related to the general use of the AC drive, such as application and language selection, customised parameter sets or information about the hardware and software, see the Vacon NX User Manual.

5.18 EXPANDER BOARDS (CONTROL PANEL: MENU M7)

The M7 menu shows the expander and option boards attached to the control board, and the board-related information. For more information, see the Vacon NX User Manual and the Vacon I/O option board manual.

6. DESCRIPTION OF PARAMETERS

6.1 BASIC PARAMETERS

2.1.1 Grid Nominal Voltage V ID 110

This parameter sets the incoming line voltage for the regenerative drive. Set this parameter to the nominal line voltage at the installation site. Used also as a reference point for grid voltage protection functions. Use G2.2.8 Voltage Correction for static voltage correction.

When transformer parameters are given, this parameter will be voltage reference of grid when operating in Island and uGrid modes. When transformer rating is different than 1:1 System Rated DC parameter must be given so that AFE operation will work correctly and MCB is closed at correct voltage level.

2.1.2 Grid Nominal Frequency Hz ID 1532

Micro Grid and Island mode frequency set point. In Micro Grid mode used as a reference point for the Base Current reference and drooping. In AFE mode used as a reference point for frequency protection functions. Use G2.11 FreqDroopOffset for static frequency adjustment.

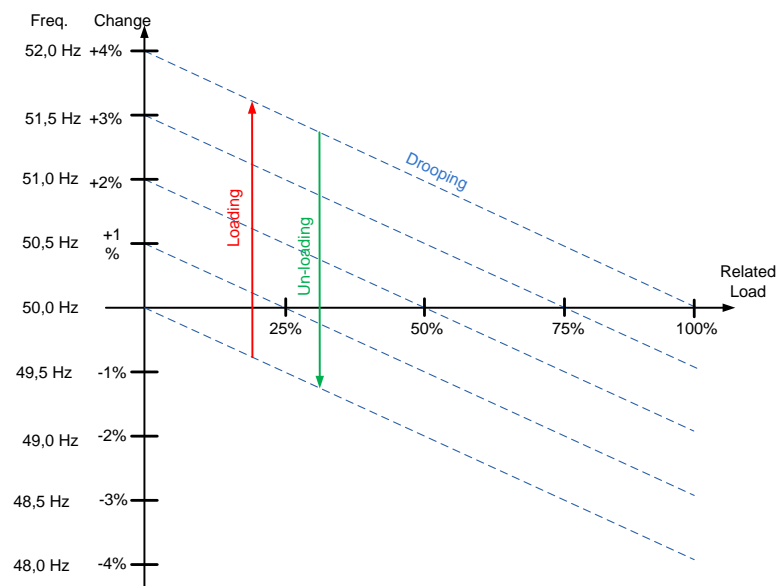

Figure 10.

2.1.3 *System Rated Current A ID 113*

The rated current capacity of the supply or the transformer May need to be set if AFE is oversized compared to LCL or feeding transformer capacity or feeding supply. It's not recommended to increase this reference current value from I_H current.

The active current and the reactive current are scaled to this parameter as is the current cutter level.

For testing purposes (FAT) feeding transformer should not be less than 20% of the unit nominal current or following breakers or fuses.

2.1.4 *System Rated Cos Phi ID 120*

Enter the system rated Cos Phi.

2.1.5 *System Rated kVA ID 213*

Enter the system rated kVA.

2.1.6 *System Rated kW kW ID 116*

Set the the rated active power of the system.

2.1.7 *Nominal DC ID 1805*

This value is used as a reference point for DC Voltage reference. Grid Nominal Voltage is not used because System Nominal DC may not be connected to Grid Nominal Voltage.

Recommended to set to highest DC Source voltage of the system to have common reference point.

Based on:

Grid voltage: Grid Nominal Voltage * 1.35

Generator Voltage: Motor/Generator nominal voltage * 1.35

DC-DC Converter: Maximum battery DC voltage.

2.1.8 *Parallel AFE ID 1501*

Set this to 1 if more than one unit is connected to same DC bus.

0 = Single AFE

1 = Parallel AFE

When you select parallel AFE, DC drooping is set to 3.00% and modulation is synchronised to reduce circulating current if the drives are in a common DC bus.

6.1.1 TRANSFORMER PARAMETERS

These parameters are used to scale voltage so that the parameter P2.1.1 Grid Nominal Voltage can be given a value as actual grid voltage. The drive will calculate the actual drive terminal voltage based on these values.

NOTE: When ratio is different than 1:1 also P2.1.7 System Nominal DC parameter must be given so that MCB is closed at correct voltage level and AFE mode DC Voltage reference will give correct DC-Link Voltage.

2.1.9 Transformer GC Side Voltage ID 1850

Set the transformer nominal voltage on Grid Converter side (U4).

2.1.10 Transformer Grid Side Voltage ID 1851

Set the transformer nominal voltage on Grid side (U5).

2.1.11 Transformer Phase Shift ID 1852

Set the transformer phase shift. Difference in angle, between U3 and U5. When OPT-D7 measurement is connected to U5 (i.e. to ship grid). This information is used if OPT-D7 assisted AFE start synchronization is activated. Usually Dyn11 transformer has 30.0 degree phase shift.

NOTE: Synchronization to external grid will use different set of parameters for phase shifts.

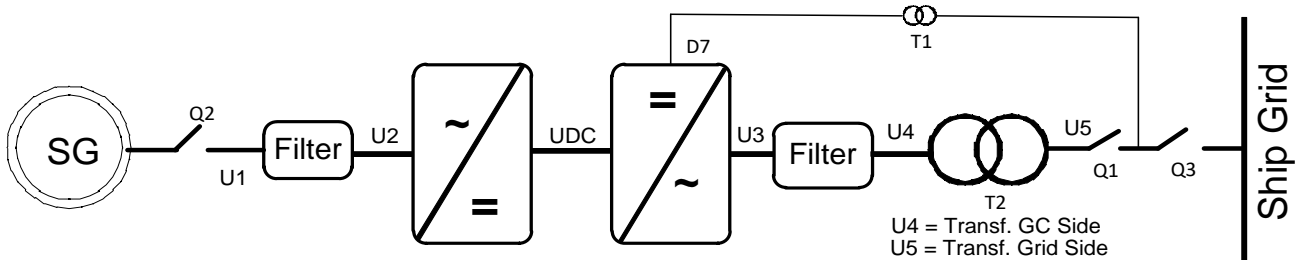

Figure 11.

P2.1.7 Identification ID631

Identification function will calibrate current measurement.

0 = No Action

1 = Current measurement offset

6.2 REFERENCE HANDLING

2.2.1 DC Voltage Reference ID 1462

This parameter sets the DC Voltage reference in % of the P2.1.7 System Nom. DC.

Final DC Voltage Ref (V1.1.2) = System Nom. DC * DC Voltage Reference

The DC Voltage will be maintained at this level when the regenerative unit is running.

There is internal limitation to reference: For 500V units the maximum limit is 797 Vdc and for 690V units the maximum limit 1099 Vdc.

The maximum limit can be monitored from V1.1.15 DC Ref Max Lim.

NOTE! If DC voltage exceeds the values below in STOP state, the drive will lose READY state:

- 797 Vdc for 500V unit, trip limit 911 Vdc
- 1099 Vdc for 690V unit, immediate trip limit 1200 Vdc, U2t protection above 1100 Vdc.
- 1136 Vdc for LC 690V voltage class 8 (Order code example: NXA15008_ _ _ _ _W)

NOTE! When transformer ration is different than 1:1 also P2.1.7 System Nominal DC parameter must be given so that MCB is closed at correct voltage level and AFE mode DC Voltage reference is giving correct DC-Link Voltage.

By default the internal DC voltage reference is kept the same as the actual DC voltage when the drive is in STOP state, or the operation mode is Island or Micro Grid. This is to make the change to the AFE mode smoother when the change is done on the fly.

2.2.2 Reactive Current Reference ID 1459

This parameter sets the reference for the reactive current in % of the System Rated Current.

This can be used for power factor correction of AFE system or reactive power compensation. Positive value gives inductive compensation whereas negative value gives capacitive compensation.

In uGrid mode 100.0 % reactive reference will decrease voltage by set voltage drooping value.

NOTE: Reactive Current reference does not affect voltage in island mode operation.

6.2.1 DC REFERENCE TUNING

2.2.3.1 DC Drooping ID 620

When AFEs are used in parallel in independent mode, drooping can be used for current balancing. The DCV voltage reference drooping is set as % of the active current reference.

For example, if drooping is 3.00% and active current is 50%, the DC voltage reference is reduced by 1.5%. With drooping, paralleled units can be balanced by adjusting the DCVOLTReference to slightly different values.

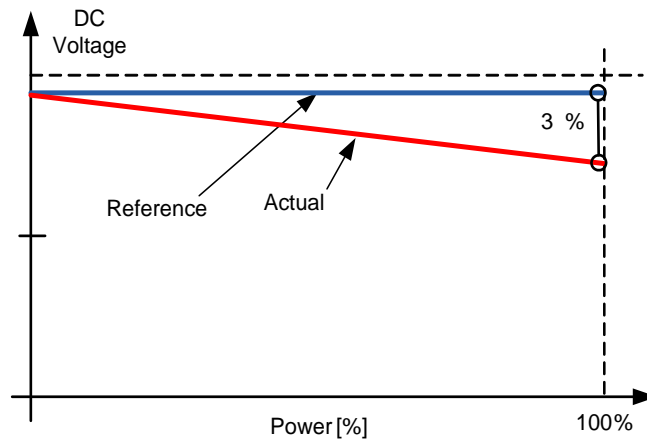

Figure 12.

2.2.3.2 DC Voltage Ramp Rate ID 1199

This parameter defines the ramp rate for the DC voltage reference change. The rate is defined as %/s.

By default the internal DC voltage reference is kept the same as the actual DC voltage when the drive is in STOP state, or the operation mode is Island or Micro Grid. This is to make the change to the AFE mode smoother when the change is done on the fly.

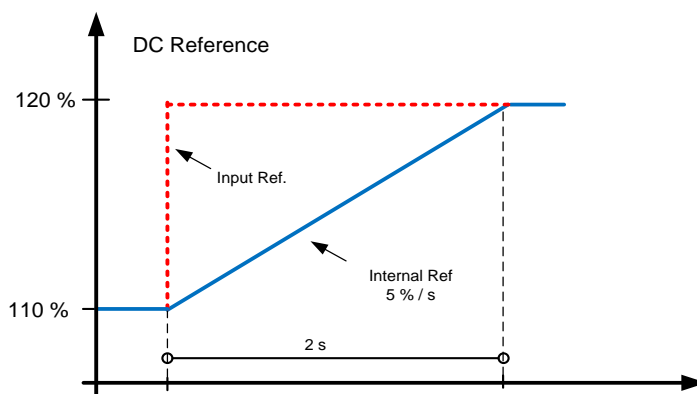

Figure 13.

2.2.3.3 DC Voltage Reference Filter TC ID 1760

By default the internal DC voltage reference is kept the same as the actual DC voltage when the drive is in STOP state, or the operation mode is Island or Micro Grid. This is to make the change to the AFE mode smoother when the change is done on the fly.

This will prevent over current and current spikes when the control mode is changed.

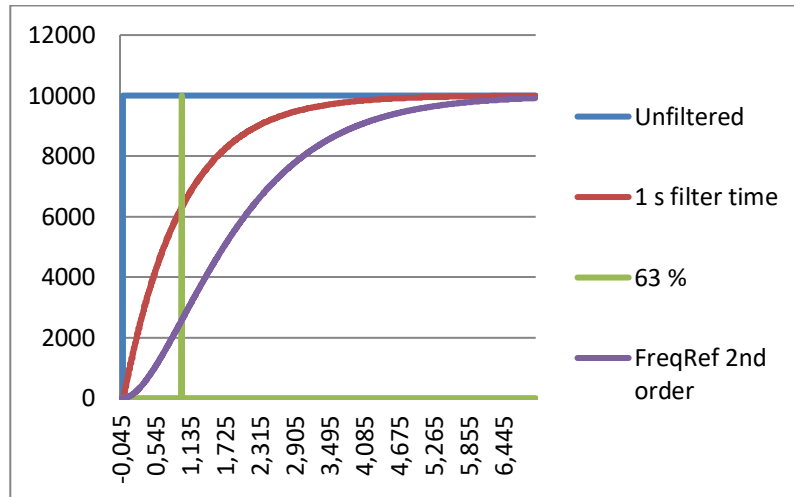

Figure 14.

2.2.3.4 DC Reference Offset ID 1776

Offset for DC Reference, used to balance parallel unit active current while using same DC Reference P2.2.1. in all units.

6.2.2 POWER /FREQUENCY REFERENCE

2.2.4.1 Frequency Drooping Offset ID 1791

This parameter is used to adjust the base frequency for drooping purposes. For example, if drooping is set to 2 Hz this parameter can be set to 1 Hz so that when the load is 50%, the frequency will be at the nominal point. The offset can also be set by the supply frequency parameters. However, in that case the grid frequency protection function will also use this increased value as a reference point and makes the protection function activate at the wrong frequency.

When you use this parameter for drooping purposes, the supply frequency can be left to the nominal value.

Final frequency reference is also limited by G2.9.7 frequency warning limits.

2.2.4.2 Frequency Down (DigIn) ID 417

Select a digital input to decrease the base frequency with a set ramp rate.

See also ID1700 FB Micro Grid CW1 Bit 4 Power Down

2.2.4.3 Frequency Up (DigIn) ID 418

Select a digital input to increase the base frequency with a set ramp rate. Frequency change is also limited by G2.3 Ramp Time and Ramp Range.

See also ID1700 FB Micro Grid CW1 Bit 5 Power Up

2.2.4.6 Base Current Reference ID 1533

The Base Current Reference determines offset for frequency reference within Frequency Drooping. For example, if frequency drooping is set to 2.000 Hz and grid frequency is constant 50 Hz with very small or nonexistent changes (isochronous or strong grid), and if 100% of Base Current Reference is given, the drive will feed 100% power to the grid. The situation is the same with the frequency reference set to 52 Hz and with 2.000 Hz drooping.

Base current reference can be used together with selection 3 of P2.11.5 StartPowerMode: Isochron.Gen. This selection will keep the drive frequency reference same as the grid frequency, and the power that is fed or taken from the drive is solely defined by the Base Current Reference parameter.

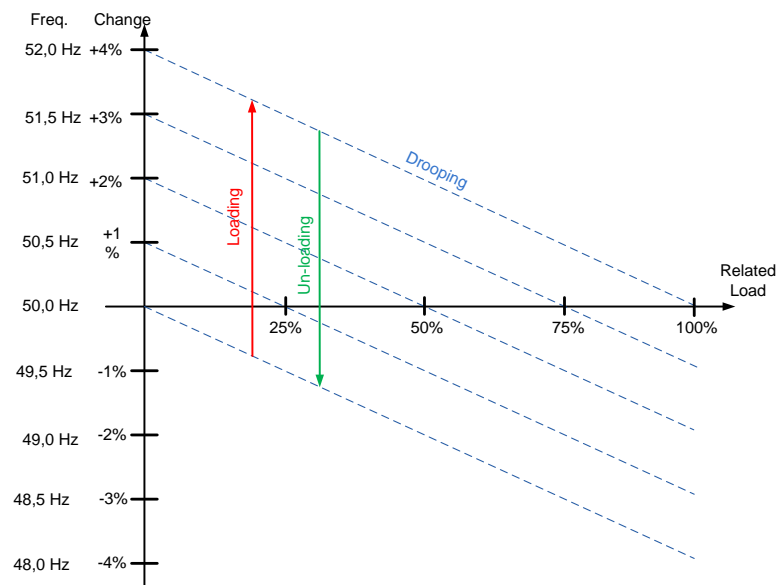

Figure 15.

2.2.4.7 BaseReference Ramp Rate ID 1536

This parameter defines the increase rate of the base current reference when the reference is changed or the drive is started.

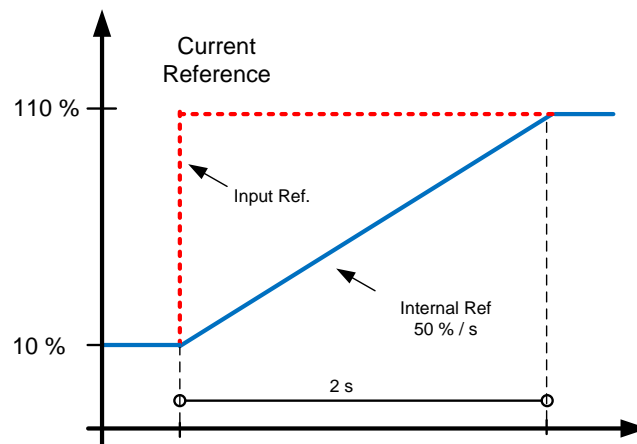

Figure 16.

2.2.4.8 Base Reference to Zero ID 1537

This parameter defines in which situations Base Current Reference is set to the value of ID1538 BaseRefAtStop.

0 = No action.

1 = Reference set to ID1538 when at STOP state.

2 = Reference set to ID1538 when AFE mode is active.

3 = Reference set to ID1538 when AFE mode is active or drive in STOP state.

2.2.4.9 Base Reference at Stop State ID 1538

Base reference on situation selected by ID1537 Base Reference to Zero. Reference is ramped after start command to ID1533. This parameter defines power level that is injected to grid right after synchronisation.

NOTE! The actual power will be determined by the set supply frequency, drooping and the start power mode.

2.2.4.10 Frequency (Power); MotPot Reset ID 367

Select reset function for motor potentiometer function. i.e. Power Reference.

0 = No action.

1 = MotPot power adjustment is reset at stop state.

2 = MotPot power adjustment is reset when operation mode is AFE.

3 = MotPot power adjustment is reset at stop state or operation mode is AFE.

6.2.3 REFERENCE ADJUST FUNCTIONS

6.2.3.1 Reactive Current Reference

2.2.5.1 *Reactive Adjust Rate* ID 1557

Defines the rate that is used to change the reactive current reference when Up and Down inputs are used.

2.2.5.2 *Reactive Ref Up (DigIn)* ID 1553

Select a digital input to increase the reactive reference with a set ramp rate.

2.2.5.3 *Reactive Ref Down (DigIn)* ID 1554

Select a digital input to increase the reactive reference with a set ramp rate.

2.2.5.4 *MaxReactiveAdjust* ID 1559

Maximum adjustment that MotPot function can make to reactive current reference.

6.2.3.2 AC Voltage Reference

P2.2.6.1 *Voltage at field weakening point* ID 603

Above the field weakening point, the output voltage remains at the set value. Below the field weakening point, the output voltage depends on the setting of the U/f curve parameters.

P2.2.6.2 *Field weakening point* ID 602

The field weakening point is the output frequency at which the output voltage reaches the field weakening point voltage. Set this to level where generator's AVR starts to decrease voltage as a function of generator speed.

P2.2.6.3 *Voltage Correction* ID 1790

This parameter is used to compensate the zero-load voltage drop in grid side when running in Micro Grid or island mode. The supply voltage parameter can also be used for this purpose, but Grid Voltage D7 protection uses this increased value for reference too. When using this parameter for compensation, the supply voltage can be left to nominal value.

NOTE! Some cases when inductor size and losses are compensated, the zero-load voltage may need to decrease.

P2.2.6.4 *Capacitor Size* % ID 1460

AFE: This parameter defines the reactive current going to the LCL filter capacitor. It compensates the LCL effect to the reactive current by adjusting the reactive current reference internally. The inductor size is also added to compensation. If set correctly, the power factor on the grid side will be 1.

Island and Micro Grid: Not used.

P2.2.6.5 Inductor Size % ID 1461

AFE:

This parameter defines voltage losses in percentage of the nominal voltage at 100% active current. This value is internally added to the reactive current reference thus giving power factor 1 on the grid side, if set correctly together with Capacitor Size. The transformer and feeding cables can be compensated by increasing this value.

Island and Micro Grid:

This parameter defines the voltage increase in percentage of the nominal voltage at 100% reactive current.

- Supply Voltage: 400 Vac
- Inductor Size: 15.0 %
- Inductor losses: 15.0 %
- Reactive Current: 30.0 %
- Active Current: 50.0 %

$400 \text{ Vac} * 30,0 \% * 15,0 \% = 18 \text{ Vac}$. Increase of voltage from reactive current.

Voltage drooping will decrease the final voltage if it is used.

P2.2.6.6 Inductor Losses % ID 1465

AFE: Not used.

Island and Micro Grid: This parameter defined voltage increase in percentage from Inductor size at nominal voltage at 100% active current.

- Supply Voltage: 400 Vac
- Inductor Size: 15.0 %
- Inductor losses: 15.,0 %
- Reactive Current: 30.0%
- Active Current: 50.0 %

$400 \text{ Vac} * 50,0 \% * 15,0 \% * 15,0 \% = 4,5 \text{ Vac}$. Increase of voltage from active current.

Voltage drooping will decrease the final voltage if it is used.

Together with inductor size and inductor losses voltage will be increased

$18 \text{ Vac} + 4,5 \text{ Vac} = 22,5 \text{ Vac}$ from Supply Voltage parameter -> 422,5 Vac.

2.2.6.7 Voltage Down (DigIn) ID 1551

Select a digital input to decrease the supply voltage with a set ramp rate.

2.2.6.8 Voltage Up (DigIn) ID 1550

Select a digital input to increase the supply voltage with a set ramp rate.

2.2.6.9 Voltage Adjust Rate ID 1555

Defines the rate that is used to change the base voltage when Up and Down inputs are used.

2.2.6.10 Voltage Maximum Adjust ID 1639

The maximum adjustment to the voltage when controlling reactive power.

2.2.4.11 Voltage; MotPot Reset ID 1640

Select reset function for motor potentiometer function,

0 = No action.

1 = MotPot adjustment is reset at stop state.

2.2.4.12 Start Voltage Mode ID 1641

This parameter select how internal voltage reference is used in Micro Grid mode. Change that this function can do to Field Weakening Point voltage is limited by ID1880 and ID1881, Supply Voltage warning limits.

0 = Start Zero Reactive Power OPT-D7

The option board D7 is used to monitor the grid voltage and uses this as a starting point for reactive power drooping control.

1 = Drooping

The drive does not control the power to zero but goes directly to the drooping control with set parameters.

3 = Keep Zero Reactive Power

The drive will follow the line voltage exactly, so the voltage change will not change the reactive power of the Micro Grid application. In this mode, reactive power is controlled by the reactive current reference or Voltage Motor potentiometer.

2.2.4.13 Reset Zero Q Delay ID 1642

This parameter defines delay when Zero Reactive Power is reset, returning internal voltage compensation back to zero. Setting this value to zero will keep function active.

6.3 RAMP CONTROL**P2.3.1 Ramp Time ID 103**

This parameter defines the time required for the frequency to increase and decrease between zero frequency and P2.3.2 Ramp Range.

P2.3.2 Ramp Range ID 232

This parameter defines the frequency range where the ramp time is related. Starting from zero frequency.

6.4 INPUT SIGNALS

6.4.1 BASIC SETTINGS

P2.4.1.1 Start/Stop Logic Selection ID 300 "Start/Stop Logic"

This parameter defines the start/stop logic when using I/O control.

0 Start – No Act – Start Drive – No Action

Start 1: closed contact = start command DI "Start 1"

1 StartP-StopP – Start Pulse – Stop Pulse

3-wire connection (pulse control):

DIN1: closed contact = start pulse

DIN2: open contact = stop pulse, falling edge.

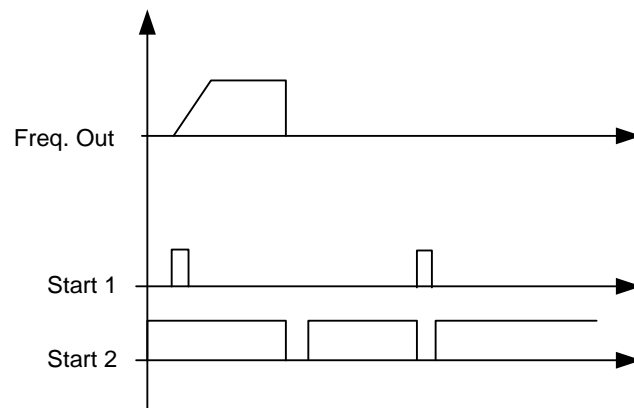

Figure 17. Start pulse/ Stop pulse.

The selections including the text *Rising edge required to start* is be used to exclude the possibility of an unintentional start when, for example, power is connected, re-connected after a power failure, after a fault reset, after the drive is stopped by Run Enable (Run Enable = False) or when the control place is changed. The Start/Stop contact must be opened before the motor can be started.

2 RPuls – RPuls – Rising pulse start – Rising pulse stop

Start 1: closed contact = Start command DI "Start 1"

Start 2: closed contact = Stop command DI "Start 1"

2.4.1.2 *Input Inversion* ID 1091

Bit selection to invert input signal logic.

B00 = INV Open Contactor

B01 = INV Ext. Fault 1

B02 = INV Ext. Fault 2

B03 = INV Enable CB Close

6.4.2 DIGITAL INPUT SIGNALS

2.4.2.1 *Start Signal 1* ID 403

Signal selection 1 for the start/stop logic. This parameter is used to select the input for Run Request signal

2.4.2.2 *Start Signal 2* ID 404

Signal selection 1 for the start/stop logic. This parameter is used to select the input for Stop Request signal.

2.4.2.3 *Open MCB* ID 1600

This parameter is used to select the input for the Open Contactor signal. The signal is used to force the main circuit breaker open (MCB or MCB2) and to stop the modulating.

When this input is used to stop AFE and open a main circuit breaker, the DC link must be discharged and recharged to close the main circuit breaker again and to continue modulation.

If the Force Main circuit breaker Open signal is not used the option 0.1 = FALSE must be selected.

When the control is on the keypad, pressing the Stop button more than a 2 second opens the MCB.

2.4.2.4 *MCB Feed Back* ID 1453

This parameter defines which digital input is used to the monitor circuit breaker status. The drive monitors the status and does not start if the state of the contactor does not correspond to the required status, that is, is open when it should be closed.

If the status of the main circuit breaker is not monitored, there will be a 3 s forced delay before drive starts.

2.4.2.5 *Fault Reset* ID 414

Contact closed: all faults are reset. Rising edge.

2.4.2.6 *Ext Fault 1* ID 405

Contact closed: the fault is displayed and the motor stopped. Fault 51. Can be inverted by the input inversion control.

2.4.2.7 *Ext Fault 2* ID 406

Contact open: the fault is displayed and the motor stopped. Fault 51. Can be inverted by the input inversion control.

2.4.2.8 *Run Enable* *ID 407*

When the signal is low, the drive will lose READY status.

Contact open: the start of drive disabled.

Contact closed: the start of drive enabled.

6.4.2.1 Synchronization to external grid

Synchronization logic is activated when digital output P2.5.1.11 NET CB Cont. is > 0.10. In this function OPT-D7 needs to be connected to external grid side and cannot be used for voltage compensation.

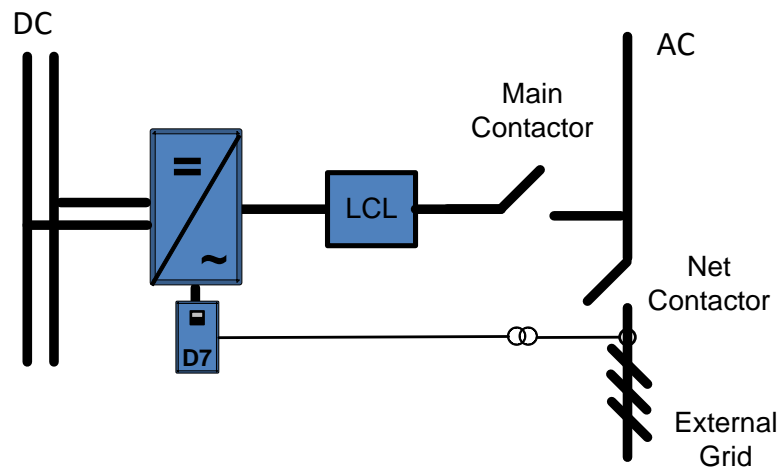

Figure 18.

2.4.2.9 NET Synchronisation ID 1602

This input is used to the synchronisation of the external network when the drive is already generating network but in a different phase. It can be used only when OPT-D7 board is installed and measurements are on the external network side.

When the input is activated, the drive uses line frequency as a frequency reference and adjusts the voltage angle to correspond with the line voltage angle with given hysteresis.

2.4.2.10 NET Close Enabled ID 1705

An interlock for the NET contactor (shore). Used as information from Shore side is NET close is allowed.

If the interlock is not used in the system, the option 0.2 = TRUE must be selected.

2.4.2.11 NET Close Request ID 1604

A command to close NET (shore) contactor. The closing will take place only when the drive is synchronised to the grid (shore).

This function is needed when the drive is already making a grid and needs to be synchronised to another grid that cannot be synchronised to the grid that the drive is making.

2.4.2.12 NET Contactor Feedback ID 1660

This parameter determines if the drive monitors the status of the NET contactor (shore) of the unit. The drive will switch from Island mode to Micro Grid mode if the control mode 4 / Island – Micro Grid is used.

If the status of the NET contactor is not monitored in the system, the option 0.1 = FALSE must be selected.

2.4.2.13 Forced AFE Mode ID 1540

Forces the drive control mode to 0 = AFE mode.

2.4.2.14 Cooling Monitor ID 750

OK input from the cooling unit.

If the status is not monitored in the system, the option 0.2 = TRUE must be selected.

2.4.2.15 Use MCB 2 Control ID 1708

This parameter is useful if 2 different supply networks are used. With this input, it is possible to select which one is used.

When the input is HIGH, MCB 1 is opened immediately.

2.4.2.16 MCB 2 Feedback ID 1710

This parameter determines if the drive monitors the status of the main circuit breaker (MCB 2) of the unit. If the monitoring function is used, the unit monitors the status and will not start if the state of the contactor does not correspond to the required status, that is, is open when it should be closed.

If the status of the main circuit breaker 2 is not monitored in the system, the option 0.1 = FALSE must be selected.

2.4.2.17 AFE Mode 2 ID 1711

Forces mode to P2.11.8 (MODE2). Only active when P2.1.1 is in 6/Free select.

2.4.2.18 AFE Mode 3 ID 1712

When both 2.4.2.17 and 2.4.2.17 are true then P2.11.9 (Mode3) is selected. When 2.4.2.17 LOW and 2.4.2.17 HIGH, the AFE mode 1 selected. Only active when P2.11.1 is in 6/Free select.

2.4.2.19 Quick Stop ID 1213

The drive stops the modulation immediately and opens the main circuit breaker.

2.4.2.20 LCL Temperature ID 1179

The digital input from the LCL temperature monitoring.

2.4.2.21 Synch to SG Grid ID 1897

Activates the synchronisation to the shaft generator side. This option is available only if back to back AFE system is used with the system bus.

2.4.2.22 RR Enable**ID 1896**

Enables the final run request command. Used for testing purposes when precharge control is started directly from the start command and when you do not want the system to go the RUN state.

6.4.2.2 Forced control place

The digital inputs can be used to bypass parameter P3.1 Control Place, for example, in an emergency situation when PLC is not able to send command to the drive.

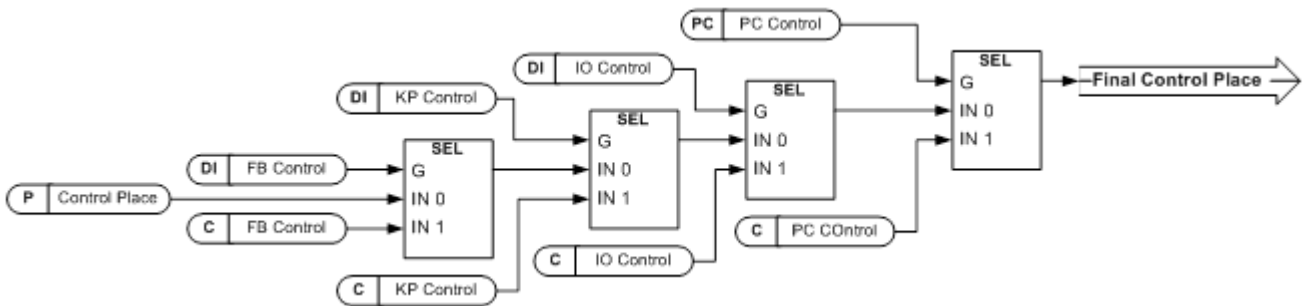

Figure 19. Control place selection priority order

P2.4.2.23 Control from I/O terminal**ID 409****“I/O Term Control”**

Contact closed: force the control place to I/O terminal.

P2.4.2.24 Control from Keypad**ID 410****“Keypad Control”**

Contact closed: force the control place to keypad.

P2.4.2.25 Control from Fieldbus**ID 411****“Keypad Control”**

Contact closed: force the control place to fieldbus.

NOTE! When the control place is forced to change, the values of Start/Stop, Direction and Reference that are valid in the control place in question are used. The value of parameter ID125 (Keypad Control Place) does not change. When the input opens, the control place is selected according to keypad control parameter P3.1 Control Place.

P2.4.2.26 Enable CB Close**ID 1619****“Enable CB Close”**

This input enables CB closing when the DC voltage is at a required level. It can be used on a battery system where drive DC is charged but it is not necessary for CB to close at this point. When the input goes high and DC is at required level, CB will close immediately. With Control Options 2 B00 MCB is also opened without need to discharge DC link

P2.4.2.27 Reset P/Hz MotPot Adjust ID 1608 "Reset P/Hz MPot"

This input will reset adjustment made with Motor Potentio meter function to Power/Hz reference.

6.4.3 ANALOGUE INPUTS 1-4

2.4.3.1	<i>AI1 signal selection</i>	<i>ID 377 "AI1 Signal Sel"</i>
2.4.4.1	<i>AI2 signal selection</i>	<i>ID 388 "AI2 Signal Sel"</i>
2.4.5.1	<i>AI3 signal selection</i>	<i>ID 141 "AI3 Signal Sel"</i>
2.4.6.1	<i>AI4 signal selection</i>	<i>ID 152 "AI4 Signal Sel"</i>

Connect the AI3/AI4 signal to the analogue input of your choice with this parameter.

When the analogue input selection parameter is set to 0.1, you can control the analogue input monitoring variable from fieldbus by assigning a process data input ID number to the monitoring signal. This allows the scaling function on the drive side to PLC input signals.

2.4.3.2	<i>Analogue input 1 signal filtering time</i>	<i>ID 324 "AI1 Filter Time"</i>
2.4.4.2	<i>Analogue input 2 signal filtering time</i>	<i>ID 329 "AI2 Filter Time"</i>
2.4.5.2	<i>Analogue input 3 signal filtering time</i>	<i>ID 142 "AI3 Filter Time"</i>
2.4.6.2	<i>Analogue input 4 signal filtering time</i>	<i>ID 153 "AI3 Filter Time"</i>

First order filtering is used for the analogue input signals 3 and 4.

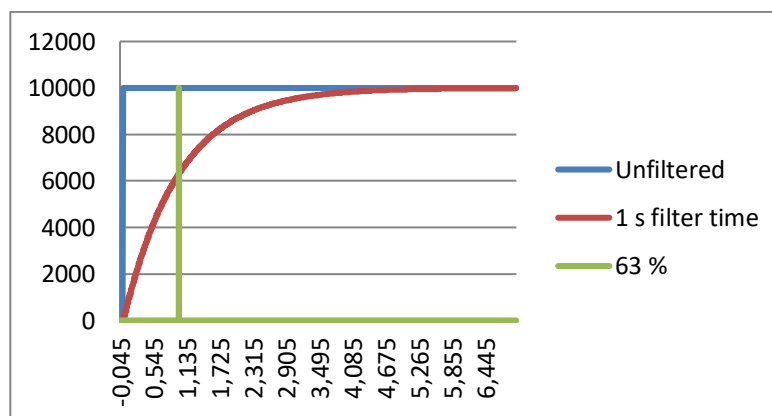

Figure 20.

2.4.3.3	<i>AI1 custom setting minimum</i>	<i>ID 321 "AI1 Custom Min"</i>
2.4.3.4	<i>AI1 custom setting maximum</i>	<i>ID 322 "AI1 Custom Max"</i>
2.4.4.3	<i>AI2 custom setting minimum</i>	<i>ID 326 "AI2 Custom Min"</i>
2.4.4.4	<i>AI2 custom setting maximum</i>	<i>ID 327 "AI2 Custom Max"</i>
2.4.5.3	<i>AI3 custom setting minimum</i>	<i>ID 144 "AI3 Custom Min"</i>
2.4.5.4	<i>AI3 custom setting maximum</i>	<i>ID 145 "AI3 Custom Max"</i>
2.4.6.3	<i>AI4 custom setting minimum</i>	<i>ID 155 "AI4 Custom Min"</i>
2.4.6.4	<i>AI4 custom setting maximum</i>	<i>ID 156 "AI4 Custom Max"</i>

Set the custom minimum and maximum input level for the AI3 signal within -160...160%.

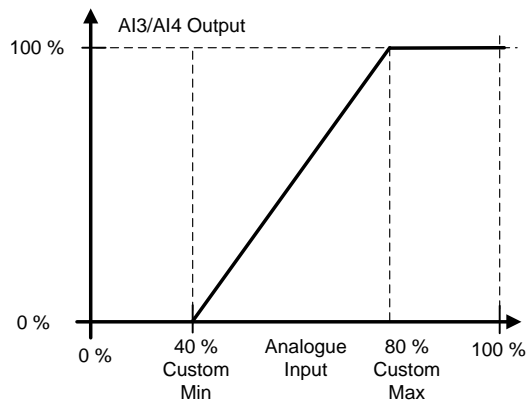

Figure 21.

2.4.3.5 AI1 signal inversion ID 387 "AI1 Signal Inv"

2.4.4.5 AI2 signal inversion ID 398 "AI2 Signal Inv"

2.4.5.5 AI3 signal inversion ID 151 "AI3 Signal Inv"

2.4.6.5 AI4 signal inversion ID 162 "AI3 Signal Inv"

The signal inversion function is useful for example in a situation where PLC sends power limit to the drive by using analogue inputs. If PLC is unable to communicate to the drive, the power limit is normally zero. When an inverted signal logic is used, a zero value from PLC means maximum power limit. This allows you to run the drive, for example, from the keypad without changing the power limit parameters.

0 = No inversion

1 = Signal inverted

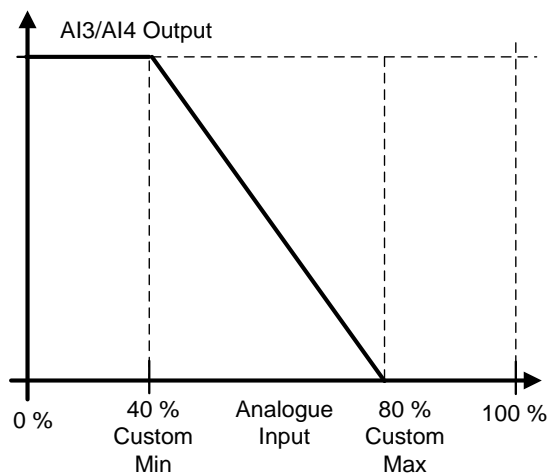

Figure 22.

6.4.3.1 Analogue input to any parameter

This function allows you to control any parameter by using an analogue input. Use a parameter to select the range of the control area and the ID number for the parameter that is controlled.

2.4.3.6	<i>Analogue input 1, minimum value</i>	<i>ID 303</i>	<i>"AI1 Scale Min"</i>
2.4.3.7	<i>Analogue input 1, maximum value</i>	<i>ID 304</i>	<i>"AI1 Scale Max"</i>
2.4.4.6	<i>Analogue input 2, minimum value</i>	<i>ID 393</i>	<i>"AI2 Scale Min"</i>
2.4.4.7	<i>Analogue input 2, maximum value</i>	<i>ID 394</i>	<i>"AI2 Scale Max"</i>
2.4.5.6	<i>Analogue input 3, minimum value</i>	<i>ID 1037</i>	<i>"AI3 Scale Min"</i>
2.4.5.7	<i>Analogue input 3, maximum value</i>	<i>ID 1038</i>	<i>"AI3 Scale Max"</i>
2.4.6.6	<i>Analogue input 4, minimum value</i>	<i>ID 1039</i>	<i>"AI4 Scale Min"</i>
2.4.6.7	<i>Analogue input 4, maximum value</i>	<i>ID 1040</i>	<i>"AI4 Scale Max"</i>

These parameters define the range for the controlled parameter. All the values are considered to be integers, so when you are controlling FWP as in the example, you also need to set numbers for the decimals. For example, FWP 100.00 must be set as *10000*.

2.4.3.8	<i>AI1 Controlled ID</i>	<i>ID 1507</i>	<i>"AI1 Control. ID"</i>
2.4.4.8	<i>AI2 Controlled ID</i>	<i>ID 1511</i>	<i>"AI2 Control. ID"</i>
2.4.5.8	<i>AI3 Controlled ID</i>	<i>ID 1509</i>	<i>"AI3 Control. ID"</i>
2.4.6.8	<i>AI4 Controlled ID</i>	<i>ID 1510</i>	<i>"AI4 Control. ID"</i>

These parameters define which parameter is controlled.

Example:

You want to control Motor Field Weakening Point Voltage by an analogue input from 70.00% to 130.00%.

Set Scale min to 7000 = 70.00%.

Set Scale max to 13000 = 130.00%.

Set Controlled ID to 603 Voltage at field weakening point.

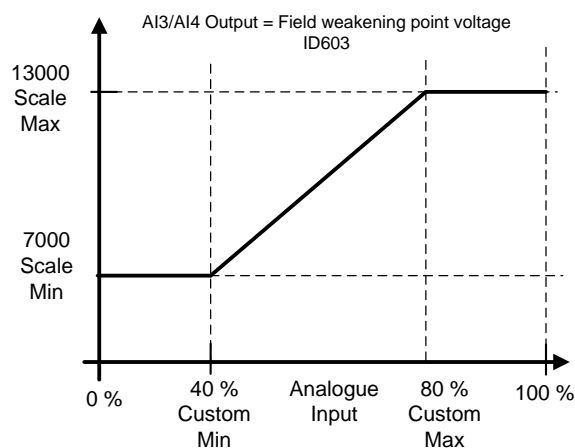

Figure 23.

The analogue input 3 signal 0 V to 10 V (0 mA to 20 mA) will control the field weakening point voltage between 70.00% and 130.00%. When setting a value, decimals are handled as integers.

6.5 OUTPUT SIGNALS

6.5.1 DIGITAL OUTPUT SIGNALS

2.5.1.1 *Main Circuit Breaker 1 Close Control* ID 1218 “MCB1 Close Cont”

AFE contactor, fixed to the relay output B.2.

When P2.5.1.2 is not activated, this output will stay high as long as MCB must be closed. When the signal goes low, MCB must be open.

When P2.5.1.2 is activated, this gives only a closing command with a 2 s pulse.

2.5.1.2 *Main Circuit Breaker 1 Open Control* ID 1219 “MCB1 Open Cont”

When this output is selected above 0.9, the drive will use pulse control for the MCB breaker. P2.5.1.1 is used to close the breaker with a 2 s pulse.

The opening command is given by P2.5.1.2 with a 2 s pulse.

2.5.1.3 *Ready* ID 432

The AC drive is ready to operate.

2.5.1.4 *Run* ID 433

The AC drive operates (the drive is modulating).

2.5.1.5 *Common Fault* ID 434

A fault trip has occurred.

2.5.1.6 *Fault, Inverted* ID 435

No fault trip has occurred.

2.5.1.7 *At Reference* ID 444

The output frequency has reached the set reference. In AFE mode, when DC voltage level is on setpoint.

2.5.1.8 *Overtemperature Warning* ID 439

The heatsink temperature exceeds unit temperature warning limit.

2.5.1.9 *Warning* ID 436

A general warning signal. The warning will go low when the reset command is given.

2.5.1.10 *Circuit Breaker 2 Close Control* ID 1709 “CB2 Close Cont”

A second AFE contactor control. The drive can connect to two different networks. This will control the main circuit breaker of the second network.

2.5.1.11 *NET Contactor Control* ID 1605

The NET contactor control. Contactor control for Grid where the drive will be synchronised. This grid is usually the shore supply. When P2.4.2.12 NET Contactor feedback is received, the drive will change the operation mode to AFE mode.

2.5.1.12 *D7 Synchronized* ID 1753

The drive is synchronised to the D7 card. Information is sent, for example, to PLC that the drive is synchronised to an external network (where D7 is connected). This output cannot be used to control the NET contactor. There is a separate output signal for that purpose.

- 2.5.1.13** *Charge control* **ID 1568 "DC Charge"**
 When this is activated, the drive will start charging of DC from the start command and go directly to RUN state. The charging starts from the start command.
- 2.5.1.14** *Common alarm* **ID 1684**
 Drive has a warning active. This indication needs to be reset separately even if the situation is over.
- 2.5.1.15** *Ready For Start* **ID 1686**
 The drive has no interlock for starting the charging and going to RUN state.
- 2.5.1.16** *Quick Stop Active* **ID 1687**
 The drive has received a quick stop command.

6.5.1.1 Fieldbus digital inputs connection

- P2.5.1.17** *Fieldbus input data 1* **ID 455 "FB Dig Input 1"**
P2.5.1.19 *Fieldbus input data 2* **ID 456 "FB Dig Input 2"**
P2.5.1.21 *Fieldbus input data 3* **ID 457 "FB Dig Input 3"**
P2.5.1.23 *Fieldbus input data 4* **ID 169 "FB Dig Input 4"**

The data from the fieldbus main control word can be led to the digital outputs of the drive. See the fieldbus board manual for the location of these bits.

- P2.5.1.18** *Fieldbus digital input 1 parameter* **ID 891 "FB Dig 1 Par ID"**
P2.5.1.20 *Fieldbus digital input 2 parameter* **ID 892 "FB Dig 2 Par ID"**
P2.5.1.22 *Fieldbus digital input 3 parameter* **ID 893 "FB Dig 3 Par ID"**
P2.5.1.24 *Fieldbus digital input 4 parameter* **ID 894 "FB Dig 4 Par ID"**

With these parameters you can define the parameter to be controlled by using FB digital input.

Example:

All option board inputs are already in use, but you want to give a DI: DC Brake Command (ID416). You also have a fieldbus board in the drive.

Set parameter ID891 (Fieldbus Digital Input 1) to 416. Now you are able to control DC braking command from the fieldbus by Profibus control word (bit 11).

It is possible to control any parameter in the same way if values 0 = FALSE and 1 = TRUE are significant for that parameter. For example, P2.6.5.3 Brake Chopper (ID504) can be switched on and off using this function (Brake Chopper: 0 = Not Used, 1 = On, Run).

6.5.2 DELAYED DIGITAL OUTPUT 1 & 2

2.5.2.1 *Dig.Out 1 Signal* ID 486

2.5.3.1 *Dig.Out 2 Signal* ID 489

Connect the delayed DO1 signal to the digital output of your choice with this parameter.

2.5.2.2 *DO1 Content* ID 312

2.5.3.2 *DO2 Content* ID 490

0 = Not used

1 = Ready

2 = Run

3 = Fault

4 = Fault inverted

5 = FC overheat warning

6 = Ext. fault or warning

7 = Ref. fault or warning

8 = Warning

9 = Reverse

10 = SynchronisedToD7

11 = Start Command given

12 = FB DIN2

13 = FB DIN3

14 = ID.Bit DO, See P2.4.x.5

2.5.2.3 *DO1 ON Delay* ID 487

2.5.3.3 *DO2 ON Delay* ID 491

2.5.2.4 *DO1 OFF Delay* ID 488

2.5.3.4 *DO2 OFF Delay* ID 492

With these parameters you can set the on and off delays to digital outputs.

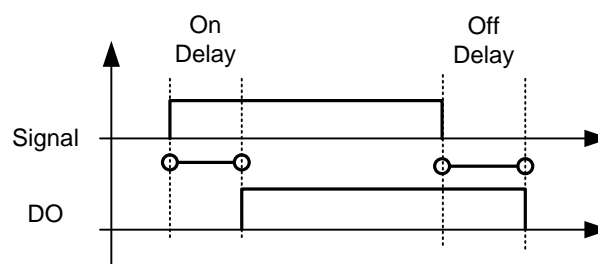

Figure 24. Digital outputs 1 and 2, on- and off-delays

2.5.2.5 *ID.Bit Free DO* ID 1216

2.5.3.5 *ID.Bit Free DO* ID 1217

Select the signal for controlling the DO. The parameter must be set in the format xxxx.yy where xxxx is the ID number of a signal and yy is the bit number. For example, the value for DO control is 1174.02. 1174 is the ID number of Warning Word 1. So the digital output is ON when the bit number 02 of the warning word (ID no. 1174), that is, *Motor underload* is high.

6.5.3 ANALOGUE OUTPUT 1 & 2 & 3

2.5.4.1 *lout 1 signal* ID 464

2.5.5.1 *lout 2 signal* ID 471

2.5.6.1 *lout 3 signal* ID 478

Connect the AO signal to the analogue output of your choice with this parameter.

2.5.4.2 *lout 1 Content* ID 307

2.5.5.2 *lout 2 Content* ID 472

2.5.6.2 *lout 3 Content* ID 479

0 = Not used

1 = DC Voltage

Scaling: 500 Vac Unit 0-1000 Vac, 690 Vac Unit 0-1317 Vdc

2 = Drive Current

Scaled to Nominal Current

3 = Output Voltage

Scaled to Nominal Voltage

4 = Active Current

Scaled to 100 %.

5 = Power

Scaled to 100 %

6 = Reactive Current

Scaled to 100 %

7 = Power Bidirectional

Scaled to -200 % to 200 %

8 = AI1

9 = AI2

10 = FB Analogue Output

11 = LineVoltage

Scaled to Nominal Voltage.

12 = FreqOut, bidirectional

13 = Control Value output

2.5.4.3 *lout 1 Filter Time* ID 308

2.5.5.3 *lout 2 Filter Time* ID 473

2.5.6.3 *lout 3 Filter Time* ID 480

Defines the filtering time of the analogue output signal. Setting this parameter value 0 will deactivate the filtering. First order filtering is used for the analogue output signals.

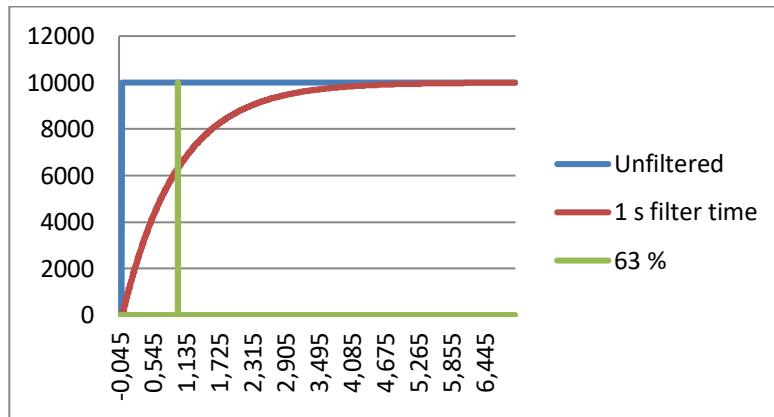

Figure 25.

2.5.4.4 *lout 1 Invert* ID 309

2.5.5.4 *lout 2 Invert* ID 474

2.5.6.4 *lout 3 Invert* ID 481

Inverts the analogue output signal:

- Maximum output signal = Minimum set value.
- Minimum output signal = Maximum set value.

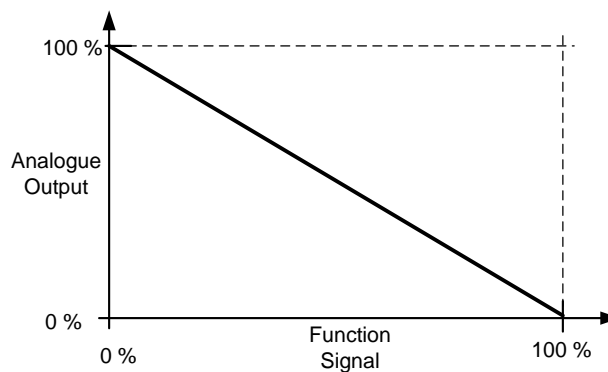

Figure 26.

2.5.4.5 *lout 1 Minimum* ID 310

2.5.5.5 *lout 2 Minimum* ID 475

2.5.6.5 *lout 3 Minimum* ID 482

0 = Set minimum value to 0 mA (0%)

1 = Set minimum value to 4 mA (20%)

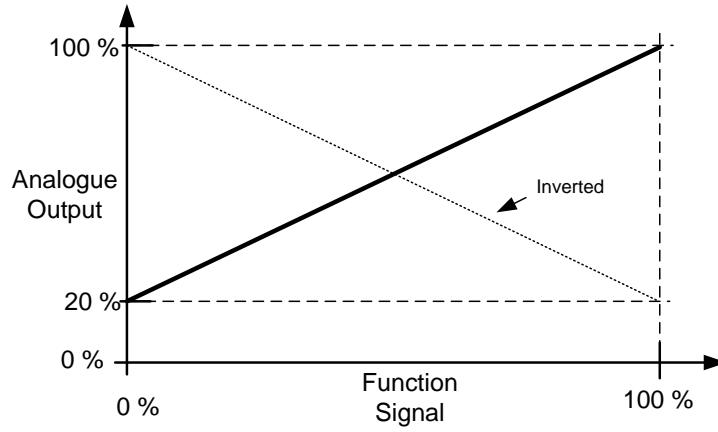

Figure 27.

2.5.4.6 *lout 1 Scale* ID 311

2.5.5.6 *lout 3 Scale* ID 476

2.5.6.6 *lout 4 Scale* ID 483

A scaling factor for an analogue output.

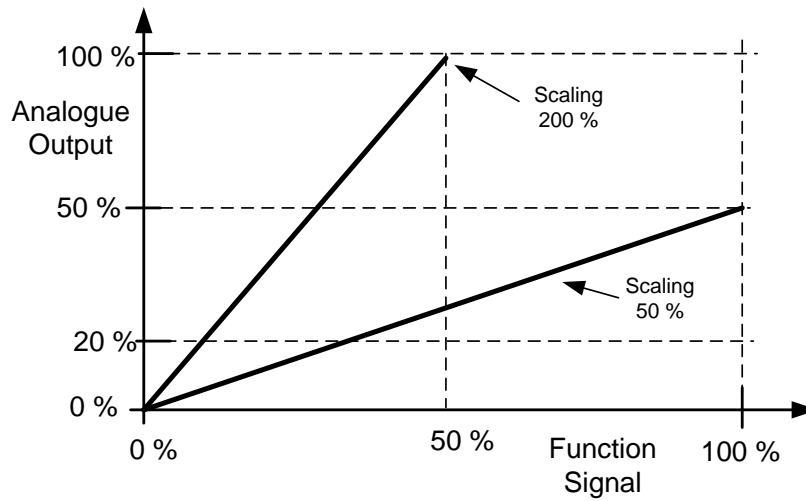

Figure 28.

2.5.4.7 *lout 1 Offset* ID 375

2.5.5.7 *lout 2 Offset* ID 477

2.5.6.7 *lout 3 Offset* ID 484

Add -100.0 to 100.0% to the analogue output.

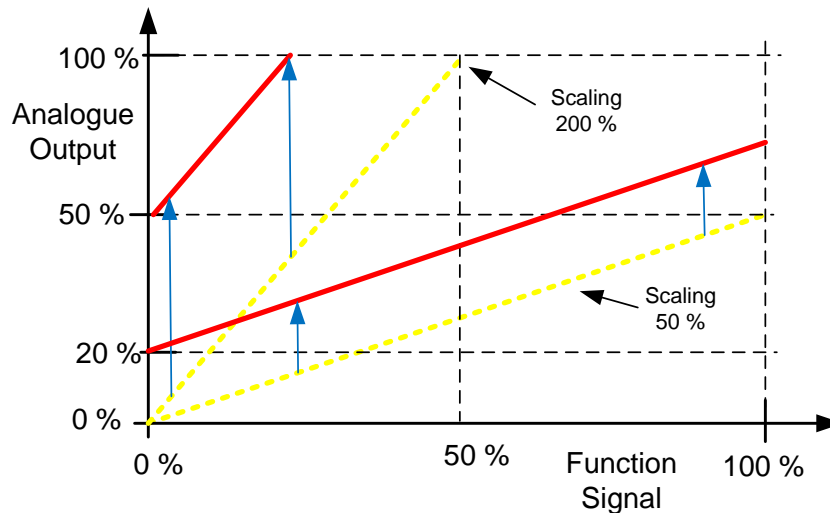

Figure 29.

6.5.4 OPTIONS

P2.5.7.1 *Output Inversion* ID 1806

With this parameter it is possible to select which output signals are inverted.

B00 = +1 = Inver Common Alarm

B01 = +2 = Invert Common Warning

B02 = +4 = Invert delayed output 1

B03 = +8 = Invert delayed output 2

P2.5.7.2 *Freq Scale Min AO* ID 1807

This parameter is used to scale the analogue output function 12 / FreqOut, bidirectional. This parameter defines the frequency where the analogue output is at the minimum. For example, when it is set to 45.00 Hz, the analogue output is 0 V, 0 mA, or 4 mA depending on signal selections.

P2.5.7.3 *Freq Scale Max AO* ID 1808

This parameter is used to scale the analogue output function 12 / FreqOut, bidirectional. This parameter defines the frequency where the analogue output is at the maximum. For example, when it is set to 55.00 Hz, the analogue output is 10 V or 20 mA depending on signal selections.

P2.5.7.4 DC Supervision Limit ID 1454

This parameter defines when FB Status Word B10 is high (ID68). The Bit is high when DC voltage is above the value set by this parameter.

P2.5.7.5 CB Close Mode ID 1607

This parameter defines how the closing of circuit breaker is handled.

0 = DC Voltage

Normal AFE operation type circuit breaker control. The circuit breaker is closed when DC voltage is at a required level.

1 = DC Voltage or Start Command

The circuit breaker is closed when DC voltage is at the required level, or from a start command if DC is at a required level. This can be used when the breaker is opened, for example, by a stop command but DC remains high. It is useful when used in a battery system.

2 = Start Command

The circuit breaker is closed from a start command if DC is at a required level.

3 = DC Voltage, Start Command or Pre-Charge Command from FB

The circuit breaker is closed when DC voltage is at the required level, or from a start command if DC is at a required level. This can be used when the breaker is opened, for example, by a stop command but DC remains high. It is useful when used in a battery system. This mode will also close MCB from FB Control Word B0 if DC-Link voltage is at required level.

P2.5.7.6 MCB At Stop Command ID 1685

The parameter defines the action for MCB when a stop command has been given.

0 = Keep closed**1 = Open CB when drive has stopped****P2.5.7.7 MCB close delay ID 1513**

The parameter defines the delay when R02 is closed after the drive has determined that MCB can be closed.

6.6 LIMIT SETTINGS

6.6.1 CURRENT LIMITS

2.6.1.1 *Current Limit* ID 107

The parameter sets the current limit for the Grid Converter unit. Set the value to correspond to the maximum peak overload for the unit or if needed, to required short circuit current (I_{SCC}).

The maximum value for air cooled unit is I_s and liquid cooled unit I_{th} . For air cooled units I_s is available when short circuit functionality is activated. See available current values from "GTC Product compatibility note" column I_s .

The drive can operate against the current limit if P2.6.1.3 Short Circuit time has been set to zero, and P2.6.1.4 High Frequency Current Limit has been enabled. Otherwise the drive will trip to a short circuit fault immediately, or after a set time delay.

NOTE! The internal protections of the drive can trip the drive before the time limit or the current level is reached.

NOTE! Set the current limit high enough so that limit is not reached in normal operation.

2.6.1.2 *Short Circuit Detection Level* ID 1620

This parameter defines the current level when the drive will start to feed reactive current to the short circuit, i.e. this is short circuit current detection level (I_{SCD}).

This is instantaneous value, related to P2.1.3 System Rated Current. ($P2.1.3 * \sqrt{2}$)

This value should be above the set current limit of the drive but below the (F1) over current trip limit ($3,2-4 * I_{th}$, depending on unit).

The recommendation is to set Short Circuit Level about 25 % higher than the value of the current limit. This will eliminate short circuit operation while already operating against current limit due current spikes that goes to short circuit detection level.

Example LC AFE unit 730 A 500 Vac :

System Rated Current (I_{SRC}): 487 A (I_{th})

Current Limit (I_{SCC}) : 730 A (I_{th})

Short Circuit Detection Level (I_{SCD}) : $\frac{730 A}{487 A} * \sqrt{2} * 1,25 = 256 \%$

In this case Short Circuit Level 212% would be equal to Current Limit in rms. The recommended value for the Short Circuit Level in the case above is 265 %. The function will be disabled if a value above 499% is given. If it is possible, adjust System Rated current to have values below 499%.

NOTE! The function requires a uGrid Licence (P3.2 uGrid Licence)

NOTE! During the short circuit grid voltage will be low; it may require that UPS is used for auxiliary voltage that MCB is kept closed during short circuit.

Example Air Cooled AFE unit 460 A 500 Vac :

System Rated Current (I_{SRC}): 385 A (I_h)

Current Limit (I_{SCC}): 693 A (I_s)

Short Circuit Detection Level (I_{SCD}) : $\frac{693 A}{385 A} \times \sqrt{2} \times 1.25 = 319 \%$

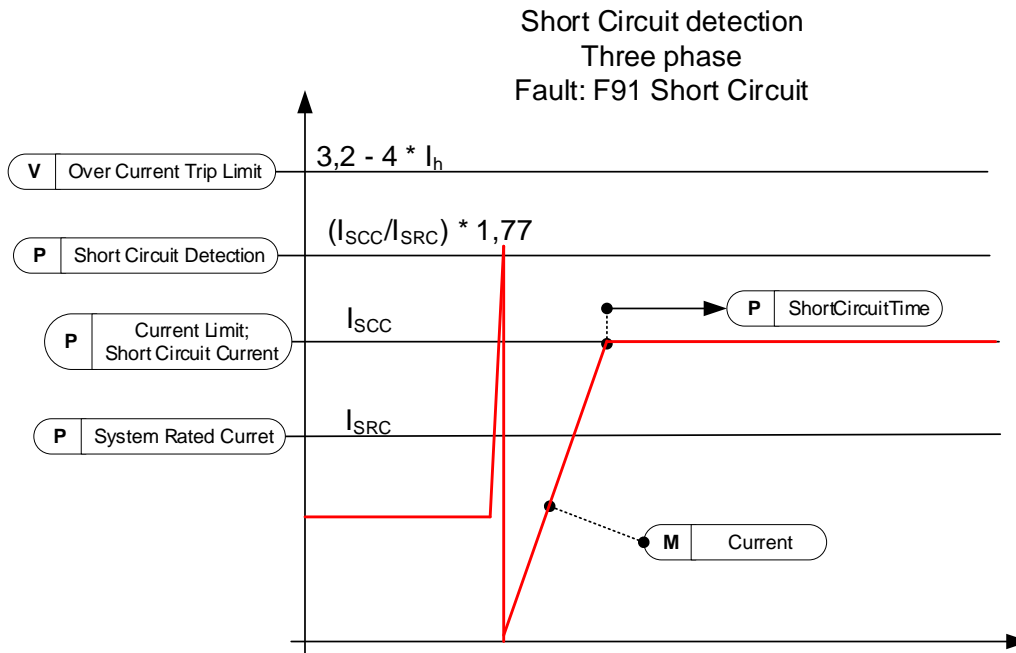

Figure 30.

2.6.1.3 Short Circuit Time

ID 1515

The maximum time that the drive can operate against the current limit.

Three phase short circuit timer needs also that voltage is below P: "Short Circuit Fault Voltage Level" before timer is started. Biphase faults monitors only the P: "Short Circuit Fault Voltage Level"

2.6.1.4 High Frequency Current Limit

ID 1517

In normal motoring drives I_s is for starting current. In Grid Converter case I_s must be enabled separately for short circuit current if current levels above I_h 50 % over load currents are needed for air cooled units. Liquid cooled units I_{th} is always the maximum limit.

The high current limit can be enabled when a licence key has been given and the drive is connected to DC (INU unit) by setting parameter to 1 / Disable. If connected to AC grid (FC unit), this parameter must be kept at 0 / Enable.

NOTE! The function requires a uGrid Licence (P3.2 uGrid Licence)

2.6.1.5 Short Circuit Fault Voltage Level

ID 1518

The BiPhase fault is detected by monitoring the supply voltage. Set this value lower than the supply voltage would be in normal operation. For three phase fault voltage needs to be below this level additionally that drive is running against current limit.

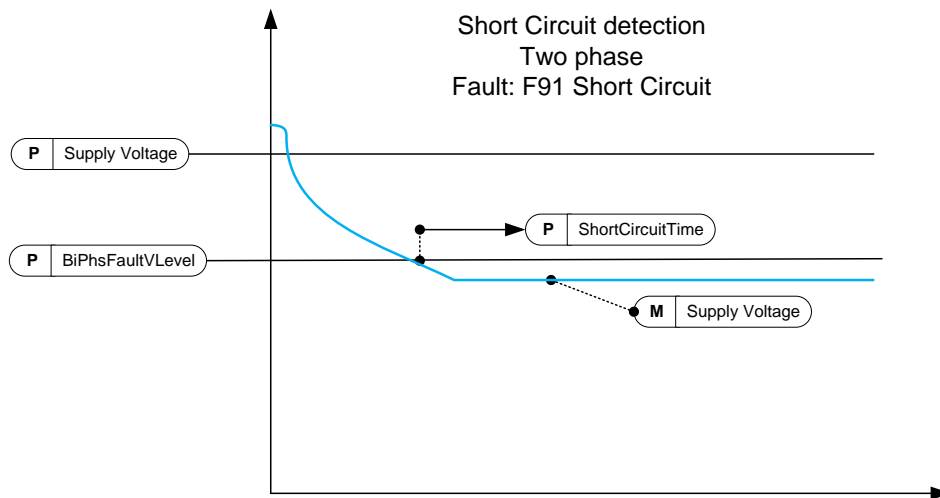

Figure 31.

2.6.1.6 Output Active Current Limit

ID 1290

This parameter sets the active current limit for the generator side operation of the regenerative unit. 100.0% is equal to nominal power, defined by System Rated Current.

2.6.1.7 Input Active Current Limit

ID 1289

This parameter sets the active current limit for the motoring side operation of the regenerative unit. 100.0% is equal to nominal power, defined by System Rated Current.

2.6.1.8 Software Over Current fault level ID1094

Software level Over Current Protection. This is instantaneous value, related to P2.1.3 System Rated Current. $(P2.1.3 * \sqrt{2})$. Drive stops to F1 Over Current Sub Code S4

6.6.2 POWER LIMITS

2.6.2.1 Output Power Limit

ID 1288

Output Power Limit, considers voltage variation on a grid and adjust Output Active Current limit to keep power same.

2.6.2.2 Input Power Limit

ID 1287

Input Power Limit, considers voltage variation on a grid and adjust Input Active Current limit to keep power same.

2.6.2.3 Power Limit Increase Rate

ID 1502

"Limit.Inc.Rate"

This parameter defines the limit increase rate. The limit will start to decrease immediately.

2.6.2.4 High Frequency Power Limit Function ID 1703

This parameter provides a high frequency power limit function for AFE. When the frequency exceeds this value, power is limited with 1 Hz slope. The value 0 = Not in use.

6.6.3 FREQUENCY LIMITS

NOTE: This functionality is not Grid Code functionality even if functionality may be similar.

2.6.3.1 Line Low Frequency Trip Limit ID 1717

If the drive output frequency goes below this level, the drive will trip to a line synch fault.

Use this limit as a final and immediate protection function for the grid or generator. In the protection group, there are protection functions that will use OPT-D7 information.

The common tripping limit of the land based grid code standard is 47.5 Hz within 200 ms.

2.6.3.2 Line High Frequency Trip Limit ID 1716

If the drive output frequency goes above this level, the drive will trip to a line synch fault.

Use this limit as a final and immediate protection function for the grid or generator. In the protection group, there are protection functions that will use OPT-D7 information.

The common tripping limit of the land based grid code standard is 50.2-51.5 Hz within 200 ms.

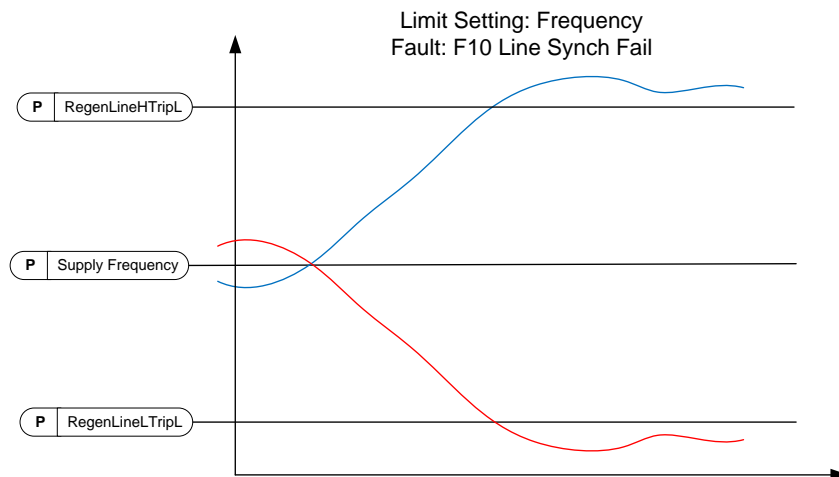

Figure 32.

6.6.4 MICRO GRID LIMITS

2.6.4.1 Current Limit Minimum ID 1621

An active current limit from AC to DC direction. This limit affects the Island and uGrid operation modes but not the AFE operation mode.

2.6.4.2 Current Limit Maximum ID 1622

An active current limit from DC to AC direction. This limit affects the Island and uGrid operation modes but not the AFE operation mode.

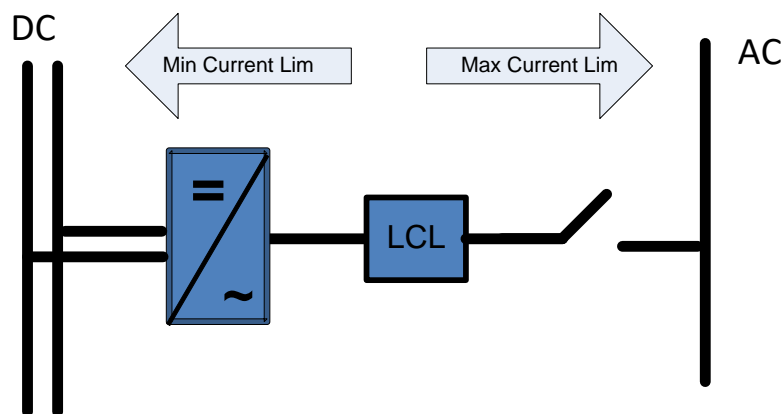

Figure 33.

2.6.4.3 Maximum Limit Increase Rate ID1502

This parameter defines the increase rate for the current limit from DC to AC direction.

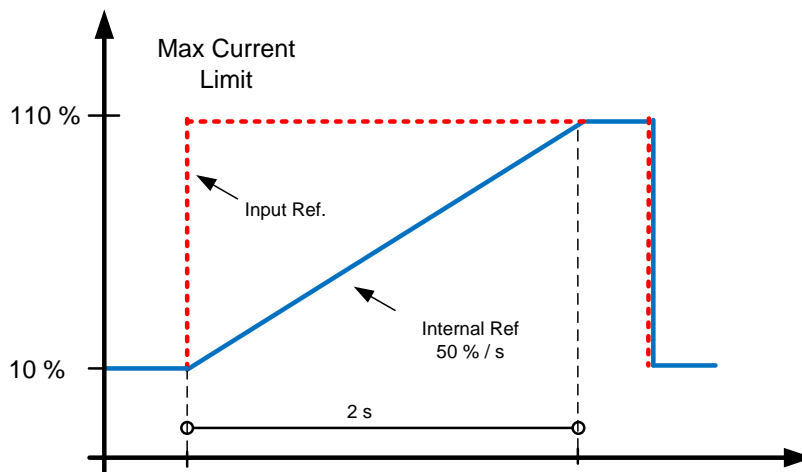

Figure 34.

2.6.4.4 Current Limit Kp ID 1623

The gain for the current limit operation.

2.6.4.5 *Current Limit Ti* *ID 1625*

The integration time for the current limit operation.

2.6.4.6 *Current Limit Max Minimum* *ID 1890*

This parameter defines the minimum limit for the maximum current limit.

Use this function to limit minimum when PLC control value to zero. The value zero will cause instability in the control. Depending on the system, the value is usually between 1% and 5%.

2.6.4.7 *Current limit to Zero Mode* *ID 1539*

Defines how the maximum current limit is handled in the STOP state.

In a starting situation, the current can increase above the reference when the grid frequency is below the base frequency. This function will decrease the starting current in starting situations.

0 = Current limit is kept at parameter level in STOP state.

1 = Current limit is set to minimum level in STOP state.

6.6.5 **DC VOLTAGE REGULATORS**

P2.6.5.1 *Under Voltage Limit* *ID 1524*

This parameter provides the under voltage regulator limit for Island and Micro Grid operation. A percentage value related to the nominal AC voltage of the drive.

DC Under Voltage Limit = Unit Nom AC Voltage * 1,35 * Under Voltage Limit

500 Vac unit: ***439 Vdc = 500 Vac * 1,35 * 65,00 %***

690 Vac unit: ***605 Vdc = 690 Vac * 1,35 * 65,00 %***

P2.6.5.2 *Over Voltage limit* *ID 1523*

This parameter provides the over voltage regulator limit for Island and Micro Grid operation. A percentage value related to the nominal AC voltage of the drive.

DC Under Voltage Limit = Unit Nom AC Voltage * 1,35 * Over Voltage Limit

500 Vac unit: ***810 Vdc = 500 Vac * 1,35 * 120,00 %***

690 Vac unit: ***1117 Vdc = 690 Vac * 1,35 * 120,00 %***

P2.6.5.3 Brake chopper ID504 "Brake Chopper"

When the AC drive is decelerating the motor, the inertia of the motor and the load are fed into an external brake resistor. This enables the drive to decelerate the load with a torque equal to that of acceleration (provided that the correct brake resistor has been selected). See separate Brake resistor installation manual. Brake chopper test mode generates pulse to resistor every second. If the pulse feedback is wrong (resistor or chopper is missing) fault F12 is generated.

0 = "Not Used" - No brake chopper used

Brake chopper not active or present in the DC link. **NOTE:** The overvoltage controller level is set to a little lower, see parameter P2.6.5.2.

1 = "On, Run" - Brake chopper in use and tested when running.

The drive's own brake chopper is activated and operational when the drive is in Run state. The drive also sends test pulses for feedback from the brake resistor.

2 = "On, Run+Stop" - Used and tested in READY state and when running

Brake chopper is also active when the drive is not in Run state. This option can be used, for example, when other drives are generating but energy levels are low enough to be handled with only one drive.

3 = "On, No test" - Used when running (no testing)

Brake chopper is active in Run state but no test pulse to resistor is generated.

Note: In the system menu, there is a parameter "InternBrakeRes". This parameter is used for brake resistor overheating calculations. If an external brake resistor is connected to the drive the parameter should be set to 'Not connected' to disable temperature calculation for the brake resistor.

P2.6.5.4 Brake Chopper Level ID1267 "BrakeChopperLeve"

Brake chopper control activation level in volt. This parameter is active when "OverVolt.Ref.Sel" is 2 / "BrakeChLevel"

For 400V Supply: $400 \cdot 1.35 \cdot 1.18 = 638\text{V}$

For 500V Supply: $500 \cdot 1.35 \cdot 1.18 = 808\text{V}$

For 690V Supply: $690 \cdot 1.35 \cdot 1.18 = 1100\text{V}$

6.7 DRIVE CONTROL

2.7.1 Switching Frequency *ID 601*

The switching frequency of the IGBT Bridge in kHz. Changing the default value can have an impact on the LCL filter operation.

2.7.2 AFE Options 1 *ID 1463*

This packed bit word is made for enabling/disabling different control options for the regeneration control.

B0 = Disable DCV reduction with a reactive reference generation with high line voltage.

B1 = Disable LCL reactive power compensation.

B5 = Disable all harmonic elimination compensation.

This is active by default. When activated, this function will reduce little 5th and 7th harmonics. This will not reduce harmonics of the grid, only the harmonics of the drive.

B8 = Enable double pulse synchronisation.

This option will generate two synchronisation pulses instead of one. It can help the synchronisation on a weak grid.

B9 = Enable soft synchronisation (\geq FI9).

This function enables zero crossing detection on drives that are FI9 or bigger. When this is active and there is a connection to the grid when the drive is in the STOP state, Supply Frequency is updated by the detected frequency.

B12 = Enable floating DC reference. DC-link voltage will follow the line voltage.

When the drive is in the RUN state, it can detect the Supply Voltage. If the supply voltage changes, also the internal DC Reference is changed so that DC voltage is:

$$DC\ Voltage = Estimated\ Supply\ Voltage * 1,35 * DC\ Reference$$

B13 = Enable use of D7 board for start synchronisation.

When an OPT-D7 board is installed, this bit will activate the synchronisation by using a voltage angle and frequency information from the D7 board. The phase order must be same in both the OPT-D7 and input phases. It is also necessary to keep the frequency on the positive side. The frequency of the D7 board can be the same as a Supply Frequency but the phase order can be still wrong.

2.7.3 AFE Options 2 *ID 1464*

This packed bit word is made for enabling/disabling different control options for the regeneration control.

B00 = +1 =

2.7.4 AFE Options 3

ID 1466

This packed bit word is made for enabling/disabling different control options for the regeneration control.

2.7.5 Start Delay

ID 1500

This parameter defines a starting delay when a run command is given. When programming different delays to parallel units, the units will start in sequence. This is necessary in parallel units to make sure that the synchronisation does not happen simultaneously in all the drives. A simultaneous start can lead to a failed synchronisation. The recommended value between the drives is 500 ms.

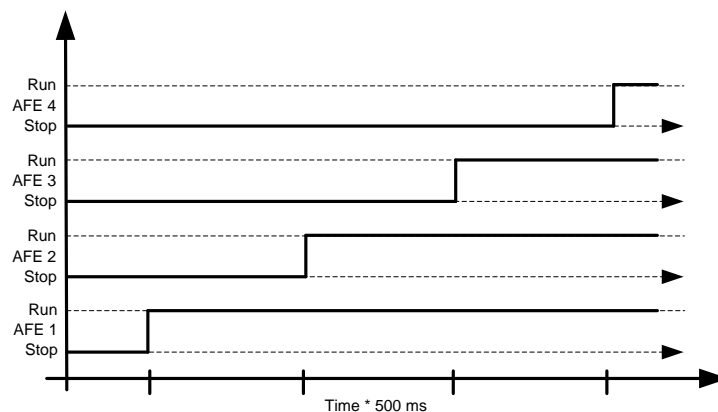

Figure 35.

2.7.6 Modulator Type

ID 1516

With this parameter you can change the modulator type. With an ASIC (HW) modulator, the current distortion is lower, but losses are higher compared to a software modulator. It is recommended to use Software modulator 1 as a default option.

0 = Hardware modulator: an ASIC modulator, with a classical third harmonic injection. The spectrum is slightly better compared to Software 1 modulator.

1 = Software modulator 1: A symmetric vector modulator with symmetrical zero vectors. The current distortion is smaller than with Software modulator 2 if boosting is used.

2 = Software modulator 2: A symmetric BusClamb, in which one switch always conducts 60 degrees either to a negative or a positive DC-rail. Switching losses are reduced without different heating of upper and lower switches. The spectrum is narrow. Not recommended for parallel units.

3 = Software modulator 3: An unsymmetric BusClamb, in which one switch always conducts 120 degrees to a negative DC-rail to reduce switching losses. The upper and lower switches are unevenly loaded and the spectrum is wide. Not recommended for parallel units.

4 = Software modulator 4: A pure sine wave, sinusoidal modulator without harmonic injection. It is dedicated to be used, for example, in back-to-back test benches to avoid a circulating third harmonic current. The required DC voltage is 15% higher compared to other modulator types.

2.7.7 *Control Options 1* *ID 1707*

B00 = +1 = Reserved

B01 = +2 = Reserved

B02 = +4 = Reserved

B03 = +8 = Disable D7 frequency monitoring for diagnostic. Used for testing purposes.

B04 = +16 = Disable D7 voltage monitoring for diagnostic. Used for testing purposes.

B05 = +32 = Keep frequency drooping while synchronising to external grid.

B06 = +64 = Enable external grid contactor closing in STOP state.

B07 = +128 = Enable changing (temporarily) MCB Control output. Used to disable MCB close for testing purposes.

B08 = +256 = Disable floating DC reference, Island and Micro Grid modes will follow actual DC.

B10 = +1024 = Bypass normal DC-Link voltage reference level for 500 Vac unit.

B11 = +2048 = Enable drive stop when OPT-D7 voltage is below P2.9.6.2 VoltLowWarnLim
This function is used to keep AFE-INU system operational during short circuit on grid side given that inertia of INU side will keep DC high enough for long enough.

B12 = +4096 = Reserved.

B13 = +8192 = Use angle information of the drive for SG synchronisation.

2.7.8 *Control Options 2* *ID 1798*

B00 = +1 = Enable CB Close (DI and FB), will also open MCB, without need of discharge DC link.

B01 = +2 = No longer available, use P2.9.1.5 FaultWarnIndicat

B02 = +4 = OPT-D7 simulation. When OPT-D7 board is not used, it is possible to use Analogue Input 3 and 4 ID write function to give the grid the Line Frequency D7 (ID1654) and Line Voltage D7 (ID1650). This enables use of grid protection functions without OPT-D7 board. Note that both line frequency and line voltages needs to be given.

B03 = +8 = Reserved

B04 = +16 = Disable uGrid mode low DC-Link power blackout prevention function.

This will disable uGrid low DC-Link voltage power limitation based on DC-Link voltage. Enables to keep correct Supply Frequency but Reactive Current is not behaving as in normal power sources. Basically same operation than Island mode but this will have drooping functions active.

B05 = +32 = Double sampling. Reduces aliasing in current measurement but increases system load slightly. May be used on battery system where having accurate zero current reference is important.

2.7.9 *Operation Time* *ID 1855*

This parameter stores the operation time. When the application is reloaded, operation hours will go to zero if this parameter is not updated.

The unit of the monitoring signal is h with two decimals.

Parameter is in this format:

XX (Years) XX (Months) XX (Days) XX (Hours) XX Minutes

1211292359 -> 12 years, 11 months, 29 days, 23 hours and 59 minutes.

6.7.1 AFE CONTROL

P2.7.10.1 *Dynamic Support Kp* *ID 1797*

P2.7.10.2 *Synch Kp* *ID 1457*

This parameter sets the gain of the synchronisation controller used to synchronise the switching to the supply.

P2.7.10.3 *Synch Ti* *ID 1458*

This parameter sets the time constant of the controller used to synchronise the switching to the supply (15 equals 7ms).

P2.7.10.4 *Active Current Kp* *ID 1455*

This parameter sets the gain of the controller for the active current of the regenerative unit.

P2.7.10.5 *Active Currnt Ti* *ID 1456*

This parameter sets the time constant of the controller for the active current of the regenerative unit (15 equals 1.5ms).

P2.7.10.6 *Synch. Kp Start* *ID 1300*

P2.7.10.7 *Voltage Control Kp* *ID 1451*

This parameter sets the gain for the DC link PI voltage controller.

*P2.7.10.8 Voltage Control Ti**ID 1452*

This parameter sets the time constant in ms of the DC link PI controller.

6.8 PROTECTIONS

6.8.1 GENERAL SETTINGS

2.9.1.1 *Thermistor Fault Response* ID 732

0 = No response

1 = Warning

2 = Fault, stop mode after fault according to ID506

3 = Fault, stop mode after fault always by coasting

Setting the parameter to 0 will deactivate the protection.

2.9.1.2 *OverTemp Response* ID 1757

2 = Fault

3 = Fault, Open MCB

4 = Fault, Open NET CB

5 = Fault, Open Main & NET CB

2.9.1.3 *Overvoltage Response* ID 1755

2 = Fault

3 = Fault, Open MAIN CB

4 = Fault, Open NET CB

5 = Fault, Open Main & NET CB

2.9.1.4 *CoolingFlt.Delay* ID 751

Protection for liquid-cooled units. An external sensor is connected to the drive (DI: Cooling Monitor) to indicate if cooling liquid is circulating. If the drive is in STOP state this is only a warning. In RUN state, the drive will issue a fault with a coast stop. This parameter defines the delay after which the drive goes to FAULT state when *Cooling OK* signal is missing.

2.9.1.5 *LCL Temperature input monitor* ID 1505

This parameter defines a response to the input filter overtemperature fault. The fault is monitored through a digital input.

2.9.1.6 *Max Charge Time* ID 1522

When the drive charging options are used, this parameter defines the maximum time limit for charging.

2.9.1.7 MCB at Fault ID 1699

Defines action for the main circuit breaker when the drive has a fault.

F1 Over Current, F31 Hardware IGBT and F41 Software IGBT will open MCB immediately regardless of the setting of this parameter.

0 = Keep closed

1 = Open at any fault situation

2.9.1.8 Start Fault Delay ID 1512

When using the master-follower system for example for a shaft generator, this parameter defines the fault delay if both drives are not started.

P2.9.1.9 Quick Stop Response ID 1758

This function will stop the drive at any case. This parameter is used to select which action is shown on keypad.

1 = Warning

2 = Fault

P2.9.1.10 Reactive Error Trip Limit ID 1759

Limit for the reactive current for the line fault detection, when the reactive current is less than the value of parameter Line Synch fault.

P2.9.1.11 MCB Fault Delay ID 1521

The delay for the main circuit breaker open fault. The delay between the control relay close command of the main circuit breaker and the acknowledge signal of the main circuit breaker. If the acknowledge signal is not received within this time, a fault F64 will be generated.

P2.9.1.12 Line Phase Supervision ID 702

Defines the response when the drive notices that one of the input phases is missing.

0 = No response

1 = Warning

2 = Fault, stop mode after fault according to Stop Function

3 = Fault, stop mode after fault always by coasting

P2.9.1.13 Response to the 4mA reference fault ID 700

The 4 mA protection monitors the analogue input signal level from Analogue Input 1 and Analogue Input 2. The monitoring function is active when the signal Custom Minimum is bigger than 16.00% and the mode is defined as a living zero (2 V or 4 mA). A fault or warning is generated when the signal goes below 3.5 mA for 5 seconds or below 0.5 mA for 0.5 seconds.

0 = No response

1 = Warning

2 = Fault

P2.9.1.14 Reactive Current Limit Response ID 1981

This function can be used to generate a fault or a warning when the reactive current exceeds 110% value.

0 = No response

1 = Warning

2 = Fault

P2.9.1.15 FaultWarnIndicat ID1940

With this parameter its possible to select how warning and fault indication as handled to digital outputs and to fieldbus

0 = Static

Static signal, as long as warning or fault is active

1 = Toggle

New fault or warning toggles signal for one second.

2 = Marine

Signal toggles in new fault or warning and status needs to be reset to get signal down.

6.8.2 TEMPERATURE SENSOR PROTECTIONS

The temperature protection function is used to measure temperatures and issue warnings and/or faults when the set limits are exceeded. The marine application supports two OPT-BH and OPT-B8 board simultaneously. One can be used for the motor winding and one for the motor bearings.

P2.9.2.1 Number of used inputs in board 1 **ID739 "Board1 Channels"**

Select used temperature sensor combination with this parameter. See also the VACON® I/O boards manual.

0 = Not used (ID Write, value of maximum temperature can be written from fieldbus)

1 = Sensor 1 in use

2 = Sensor 1 & 2 in use

3 = Sensor 1 & 2 & 3 in use

4 = Sensor 2 & 3 in use

5 = Sensor 3 in use

Note: If the selected value is greater than the actual number of used sensor inputs, the display will read 200°C. If the input is short-circuited the displayed value is –30°C.

P2.9.2.2 Board 1 Temperature response **ID740 "Board1 Response"**

0 = No response

1 = Warning

2 = Fault, stop mode after fault according to Stop Function

3 = Fault, stop mode after fault always by coasting

P2.9.2.3 Board 1 warning limit **ID741 "Board1Warn.Limit"**

Set here the limit at which the PT100 warning will be activated.

When individual warning and fault limits are activated this is first board first channel (1A).

P2.9.2.5 Board 1 fault limit **ID742 "Board1 Fault Lim."**

Set here the limit at which the PT100 fault (F56) will be activated.

When individual warning and fault limits are activated this is first board first channel (1A).

P2.9.2.5 *Number of used inputs in board 2* **ID743** *“Board2 Channels”*

If you have two temperature sensor boards installed in your AC drive you can choose here the combination inputs in use in the second board. See also the VACON® I/O boards manual.

0 = Not used (ID Write, value of maximum temperature can be written from fieldbus)

1 = Sensor 1 in use

2 = Sensor 1 & 2 in use

3 = Sensor 1 & 2 & 3 in use

4 = Sensor 2 & 3 in use

5 = Sensor 3 in use

P2.9.2.6 *Board 2 Temperature response* **ID766** *“Board2 Response”*

0 = No response

1 = Warning

2 = Fault, stop mode after fault according to Stop Function

3 = Fault, stop mode after fault always by coasting

P2.9.2.7 *Board 2 warning limit* **ID745** *“Board2 Warn. Lim”*

Set here the limit at which the second temperature sensor board warning will be activated. When individual warning and fault limits are activated this is second board first channel (2A).

P2.9.2.8 *Board2 fault limit* **ID746** *“Board2 FaultLim”*

Set here the limit at which the second temperature sensor board fault (F61) will be activated. When individual warning and fault limits are activated this is second board first channel (2A).

6.8.2.1 Individual channel monitoring

Individual channel monitoring is activated by setting one of the warning limits (per board) different than zero. Common limits in above parameters will be channel A warning and fault limits. Channel B and C limits are set with below parameters.

P2.12.2.9.1 Channel 1B Warn ID764

P2.12.2.9.2 Channel 1B Fault ID765

First board second (1B) channel warning and fault limits.

P2.12.2.9.3 Channel 1C Warn ID768

P2.12.2.9.4 Channel 1C Fault ID769

First board third (1C) channel warning and fault limits.

P2.12.2.9.5 Channel 2B Warn ID770

P2.12.2.9.6 Channel 2B Fault ID771

Second board second (2B) channel warning and fault limits.

P2.12.2.9.7 Channel 2C Warn ID772

P2.12.2.9.8 Channel 2C Fault ID773

Second board third (2C) channel warning and fault limits.

2.9.2.5 *Number of PT100 2 inputs in use* *ID 743* *“PT100 2 Numbers”*

If you have a two PT100 input boards installed in your AC drive, you can select the number of PT100 inputs in use on the second board. See also the Vacon I/O boards manual.

0 = Not used (ID Write, value of maximum temperature can be written from fieldbus)

1 = PT100 input 1

2 = PT100 input 1 & 2

3 = PT100 input 1 & 2 & 3

4 = PT100 input 2 & 3

5 = PT100 input 3

2.9.2.6 *PT100 2 Warning Limit* *ID 745* *“PT100 2 Warn. Lim”*

Set the limit at which the second PT100 warning will be activated.

2.9.2.7 *PT100 2 Fault Limit* *ID 746* *“PT100 2 FaultLim”*

Set the limit at which the second PT100 fault (F61) will be activated.

6.8.3 **EARTH FAULT**

2.9.3.1 *EarthFlt Response* *ID 1756*

2= Fault

3= Fault, Open MCB

4= Fault, Open NET CB

5 = Fault, Open Main & NET CB

2.9.3.2 *EarthFaultLevel* *ID 1333*

This parameter defines the maximum level of earth current in % of the unit current.

6.8.4 **FIELD BUS**

2.9.4.1 *Fieldbus Fault Slot D Response* *ID 733*

2.9.4.2 *Fieldbus Fault Slot E Response* *ID 761*

Set the response for a fieldbus fault if the active control place is fieldbus. For more information, see the relevant Fieldbus Board Manual.

0 = No response

1 = Warning

2 = Fault, stop mode after fault according to Stop Function

2.9.4.3 *FB WD Time* *ID 1354*

Delay time to a fieldbus fault when the pulse from PLC is missing. Setting the time to zero will disable the monitoring function.

6.8.5 EXTERNAL FAULT

- 2.9.5.1 *Response to External Fault 1* ID 701 "External Fault 1"
- 2.9.5.2 *Response to External Fault 2* ID 1504 "External Fault 2"

Defines response when a digital input signal is used to give signal about an external condition to which the drive needs to react. The external warning/fault indication can be connected to a digital output.

- 0 = No response
- 1 = Warning
- 2 = Fault

2.9.5.3 *External fault delay* ID 1506

Defines the delay for an external fault, and affects both external fault inputs.

6.8.6 GRID VOLTAGE D7

This function monitors the grid voltage by using measurement from the OPT-D7 board.

NOTE: This functionality is not Grid Code functionality even if functionality may be similar.

P2.9.6.1 *Voltage D7 Response* ID 1626

- 0 = No response
- 1 = Warning
- 2 = Fault

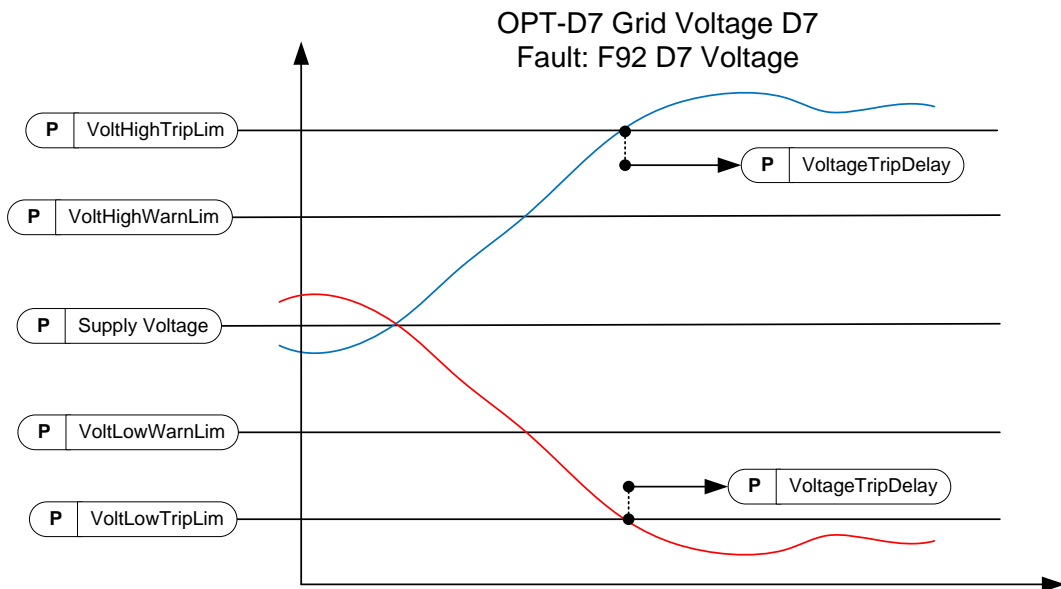

Note: Low Voltage trip from D7 board is disabled if drive has detected Short Circuit

Figure 36.

P2.9.6.2 Voltage Low Warning Limit *ID 1893*

Low limit for a warning indication. A percentage value from a set supply voltage parameter.

P2.9.6.3 Voltage Low Trip Limit *ID 1899*

Low limit for a fault indication. A percentage value from a set supply voltage parameter. The common tripping limit of the land based grid code standard is 80 % of U_n within 200 ms.

P2.9.6.4 Voltage High Warning Limit *ID 1895*

High limit for a warning indication. A percentage value from a set supply voltage parameter.

P2.9.6.5 Voltage High Trip Limit *ID 1799*

High limit for a fault indication. A percentage value from a set supply voltage parameter. The common tripping limit of the land based grid code standard is 115 % of U_n within 200 ms.

P2.9.6.6 Voltage Trip Delay *ID 1898*

Delay to a fault when the voltage has exceeded the fault levels.

6.8.7 GRID FREQUENCY

A monitoring function for the drive output frequency and the measured frequency from OPT-D7. Will also trip this when operating in pure AFE mode.

NOTE: This functionality is not Grid Code functionality even if functionality may be similar.

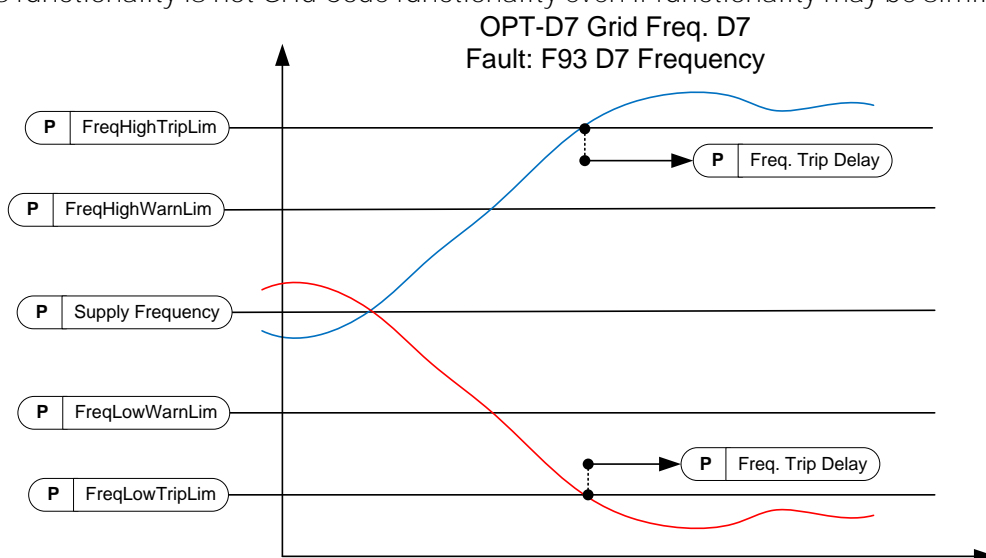

Figure 37.

P2.9.7.1 Freq. Supply Response ID 1627

0 = No response
 1 = Warning
 2 = Fault

P2.9.7.2 Freq. D7 Response ID 1628

0 = No response
 1 = Warning
 2 = Fault

P2.9.7.3 Freq. Low Warning Limit ID 1780

Low limit for a warning indication. A percentage value from a set supply frequency parameter. This also limits the adjusted frequency references.

P2.9.7.4 Freq. Low Trip Limit ID 1781

Low limit for a fault indication. A percentage value from a set supply frequency parameter. Use G2.6.3 Frequency limits for final and immediate protection.

The common tripping limit of the land based grid code standard is 47.5 Hz within 200 ms.

P2.9.7.5 Freq. High Warning Limit ID 1783

High limit for a warning indication. A percentage value from a set supply frequency parameter. This also limits the adjusted frequency references.

P2.9.7.6 Freq. High Trip Limit ID 1784

High limit for a fault indication. A percentage value from a set supply frequency parameter. Use G2.6.3 Frequency limits for final and immediate protection.

The common tripping limit of the land based grid code standard is 50.2-51.5 Hz within 200 ms.

P2.9.7.7 Freq. Trip Delay ID 1785

Delay to a fault when the frequency has exceeded the fault levels.

6.8.8 SUPPLY VOLTAGE

There is a tripping function for the drive output voltage. It is possible that the drive output voltage is higher (or lower) than the grid voltage, depending on the voltage compensation for LCL and transformer.

P2.9.8.1 Voltage, Supply response ID 1629

0 = No response
 1 = Warning
 2 = Fault

P2.9.8.2 Voltage Low Trip Limit ID 1891

When the supply voltage drops below this limit, the drive will trip to an F70 Supply voltage fault. If the drive is already at the current limit, this low voltage trip limit is not active.

NOTE! OPT-D7 is not used for detection.

Use this function for the final protection function for the grid or the generator. Delay to trip is 150 ms. The protection group has functions that use OPT-D7 for voltage level protection.

P2.9.8.3 Voltage Low Warning Limit ID 1880

When the supply voltage drops below this limit, the drive will give a warning. If the drive is already at the current limit, this low voltage trip limit is not active.

NOTE! OPT-D7 is not used for detection.

P2.9.8.4 Voltage High Warning Limit ID 1881

When the supply voltage increases above this limit, the drive will give a warning.

NOTE! OPT-D7 is not used for detection.

P2.9.8.5 Voltage High Trip Limit ID 1992

When the supply voltage increases above this limit, the drive will trip to an F70 Supply voltage fault.

NOTE! OPT-D7 is not used for detection.

Use this function for the final protection function for the grid or the generator. Delay to trip is 150 ms. The protection group has functions that use OPT-D7 for voltage level protection.

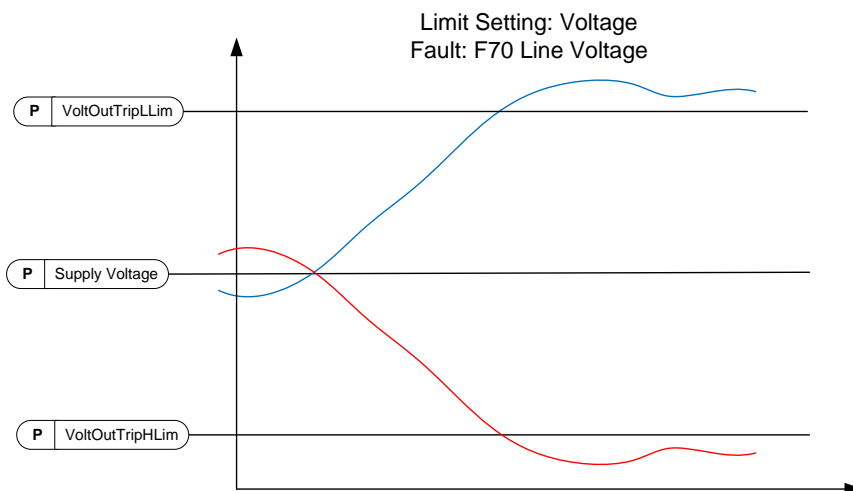

Note: This monitor voltage at drive terminal. When compensating LCL terminal voltage, Output voltage may be considerable higher on full load situations than given Supply Voltage

Note: Low Voltage trip from output voltage is disabled if drive has detected Short Circuit

Figure 38.

6.8.9 OVER LOAD PROTECTION

With this function it is possible to select if Current %, Active Current or Reactive Current is used for over load protection. Over Load is based on internal counter that is increased when input value is above 105 % level and decreased when below 105 % level. The increase and decrease occurs every 100 ms.

Tripping is made when over load counter value is over 10 000.

With parameters you can define the increase (Over load maximum step) at maximum defined input level (Over Load Maximum Input). These points define the slope for the function. For example, if the input value is in the middle of 105 % and Over Load Maximum Input values, the counter is increased by a half of the Over Load Maximum step.

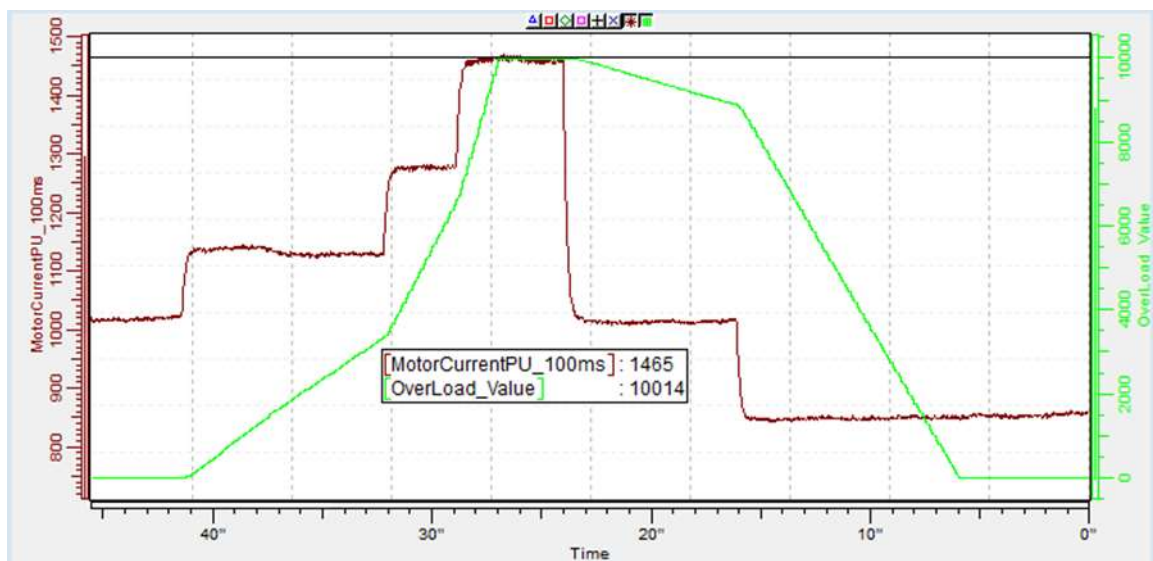

Figure 39.

2.9.9.1 Response to over load ID 1838 "OverLoadResponse"

- 0 = No response
- 1 = Warning
- 2 = Fault

2.9.9.2 Over Load Signal ID 1837 "OverLoadSignal"

- 0 = Not Used
- 1 = Total Current [%] (FW: MotorCurrentPU_100ms)
- 2 = Active Current
- 3 = Reactive Current

2.9.9.3 Over Load Maximum Input ID 1839 "OverLoadMaxIN"

Input value level where the over load counter is increased with maximum step defined by P2.9.9.4

2.9.9.4 *Over Load Maximum Step* *ID 1840* *"OverLoadMaxStep"*

Step in the over load counter when the input value is at maximum input level defined by P2.9.9.3.

6.8.10 **D7 PROTECTIONS****2.9.10.1** *THD Response* *ID 1672*

Use this parameter to select the response for the total harmonic distortion protection of the OPT-D7 option board.

0 = No response

1 = Warning

2 = Fault

2.9.10.2 *THD Warning Limit* *ID 1673*

When the total harmonic distortion measured in the voltage measured by the OPT-D7 board exceeds this limit, the drive can issue a warning.

2.9.10.3 *THD Fault Limit* *ID 1674*

When the total harmonic distortion measured in the voltage measured by the OPT-D7 board exceeds this limit, the drive can issue a fault.

2.9.10.4 *HF RMS Response* *ID 1675*

Use this parameter to select the response for the high frequency root-mean-square protection of the OPT-D7 option board.

0 = No response

1 = Warning

2 = Fault

2.9.10.5 *HF RMS Warning Limit* *ID 1676*

When the high frequency root-mean-square voltage measured by the OPT-D7 board exceeds this limit, the drive can issue a warning.

2.9.10.6 *HF RMS Fault Limit* *ID 1677*

When the high frequency root-mean-square voltage measured by the OPT-D7 board exceeds this limit, the drive can issue a fault.

6.8.11 EXTRA**2.9.11 *Fault Simulation* ID 1569 “Fault Simulation”**

With this parameter it is possible to simulate different faults without actually making, for example, an over current situation. In the point of view of the drive interface, the operation is identical to actual fault situation.

B00 = +1 = Simulates an over current fault (F1)

B01 = +2 = Simulates an over voltage fault (F2)

B02 = +4 = Simulates an under voltage fault (F9)

B03 = +8 = Simulates an output phase supervision fault (F11)

B04 = +16 = Simulates an earth fault (F3)

B05 = +32 = Simulates a system fault (F8)

This fault simulation covers a wide range of different faults in drive. See the fault description for details.

B06 = +64 = Free

B07 = +128 = Simulates an over temperature warning (W14)

B08 = +256 = Simulates an over temperature fault (F14)

The warning bit must be active for a fault to appear in simulation. If the fault bit is left active, the drive will go FAULT state at warning limit when the drive temperature rises to the warning level.

B09 = +512 = Reserved

2.9.12 *Reset Datalogger* ID 1569 “ResetDatalogger”

With this parameter it is possible to reset the datalogger to its defaults.

6.9 FIELD BUS

2.10.1 *FB Actual Value Sel* ID 1853

Enter the ID of the parameter you wish to use as the Fieldbus Actual -control variable.

2.10.2 to

2.10.9 *FB Data Out 1-8 Sel* ID 852-859

Using these parameters, you can monitor any monitoring or parameter value from the fieldbus. Enter the ID number of the item you wish to monitor as the value of these parameters

2.10.10 to

2.10.17 *FB Data Out 9-16 Sel* ID 558-565

These parameters are the same as parameters *P2.10.2-9*, but they are only available if a fieldbus board with hardware and software support for 16 process data variables is inserted in option board slot D or E.

2.10.18 to

2.10.25 *FB Data In 1-8 Sel* ID 876-883

Using these parameters, you can control any parameter value from the fieldbus. Enter the ID number of the item you wish to control as the value of these parameters.

2.10.26 to

2.10.33 *FB Data In 9-16 Sel* ID 550-557

These parameters are the same as parameters *P2.10.18-25*, but they are only available if a fieldbus board with hardware and software support for 16 process data variables is inserted in option board slot D or E.

2.10.18 *GSW Data* ID 897

With this parameter it is possible to select which data is sent in FBGeneralStatusWord.

2.10.19 *State Machine* *ID 896*

The application provides a possibility to select what kind of state machine is used.

0: Basic

This mode makes fieldbus control behave as is explained in the fieldbus board manual.

1: Standard

A simple control word that is used in modes where the control word from fieldbus is used as such. For some fieldbus boards this requires a bypass operation.

2: Vacon AFE 1

This mode uses a ProfiDrive type state machine in the application level. You can use this mode on fieldbus boards that do not have a state machine or have a possibility to bypass the state machine function in the option board.

3: Vacon AFE 2

This mode uses a ProfiDrive type state machine in the application level. You can use this mode on fieldbus boards that do not have a state machine or have a possibility to bypass the state machine function in the option board. More extensive control than Vacon AFE 1 state machine selection.

2.10.20 *FB Ref Min* *ID 850*

2.10.21 *FB Ref Max* *ID 851*

The minimum and maximum limits for fieldbus DC Voltage Reference.

2.10.22 *Control Slot selector* *ID 1440*

This parameter defines which slot is used as the main control place when two fieldbus boards have been installed in the drive. When values 6-7 are selected the drive can use the Fast fieldbus mode if a fieldbus board with proper support for it is inserted in slot D or E. When values 8-9 are selected the drive can use the Extended fieldbus mode if a fieldbus board with support for that mode is inserted in slot D or E. For more information refer to the fieldbus board manual.

0 = No Sel. Control signals are monitored from every fieldbus board.

4 = Slot D Control signals are monitored from Slot D (8 process data variables).

5 = Slot E Control signals are monitored from Slot E. (8 process data variables).

6 = Slot D with Fast fieldbus mode.

7 = Slot E with Fast fieldbus mode.

8 = Slot D with Extended fieldbus mode (16 process data variables).

9 = Slot E with Extended fieldbus mode (16 process data variables).

2.10.23	<i>SW ID.Bit selection B11</i>	<i>ID 1907</i>
2.10.24	<i>SW ID.Bit selection B12</i>	<i>ID 1908</i>
2.10.25	<i>SW ID.Bit selection B13</i>	<i>ID 1909</i>
2.10.26	<i>SW ID.Bit selection B14</i>	<i>ID 1910</i>

Select the bit that used in FB Status Word Bit 11, 12, 13 and 14.

2.10.27	<i>uGrid CW B12 parameter</i>	<i>ID 891 "uCW B12"</i>
2.10.28	<i>uGrid CW B13 parameter</i>	<i>ID 892 "uCW B13"</i>
2.10.29	<i>uGrid CW B14 parameter</i>	<i>ID 893 "uCW B14"</i>
2.10.30	<i>uGrid CW B15 parameter</i>	<i>ID 894 "uCW B15"</i>

With these parameters you can define the parameter to be controlled by using Micro Grid Control Word bits 12-15.

6.10 MICRO GRID

2.11.1 Control Mode *ID 1531*

Select the AFE operation mode.

0 = AFE

Standard AFE functionality, no licence key required. Keeps fixed DC-Link Voltage.

1 = Island

Island operation mode, cannot operate parallel with other power sources. Makes fixed voltage and frequency, i.e. no voltage or frequency drooping. Also low DC-Link Voltage limitation function is disabled. Reacts only to set DC Under Voltage limit.

2 = Micro Grid

uGrid operation mode, can operate parallel with other power sources. Parallel operation is achieved by voltage and frequency drooping. Start to reduce output frequency when not sufficient DC-Link Voltage, this will prevent reactive current generation in case of low power in DC-Link side.

3 = Island-AFE

The drive changes the control mode automatically when feedback from the external net contactor has been received.

4 = Island-Micro Grid

The drive changes the control mode automatically when feedback from the external net contactor has been received.

5 = (Reserved)

6 = Free Select

The operation mode is selected by digital inputs and AFE mode 1-3 selections.

NOTE! A licence is necessary for other than the standard AFE mode.

2.11.2 Frequency Droop ID 1543

Drooping related to the active current in Hz. Set to the same value as all other power sources drooping. Used in uGrid operation mode.

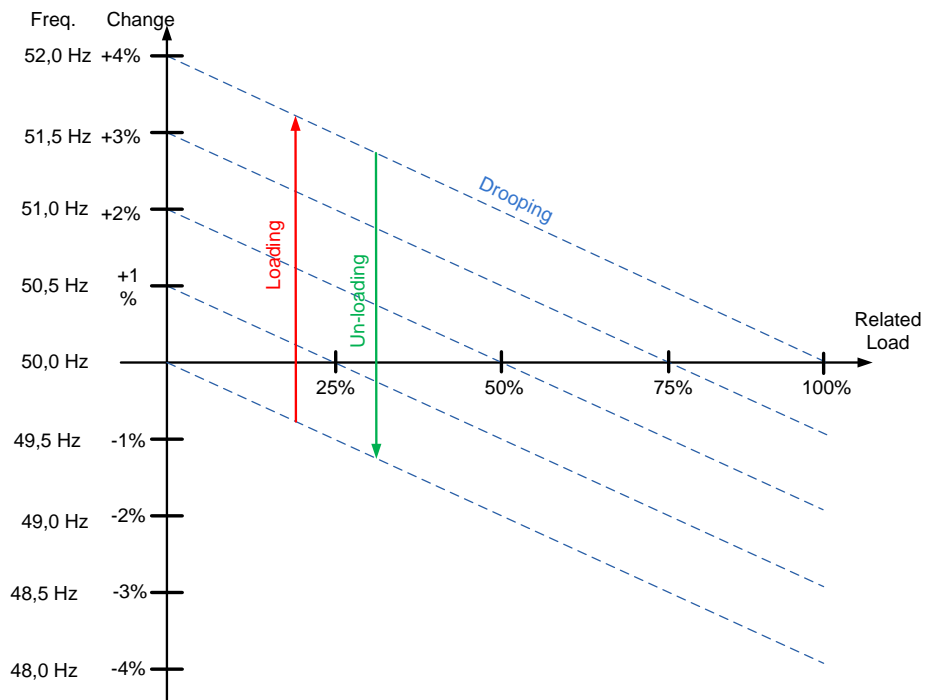

Figure 40.

2.11.3 Voltage Droop ID 1535

This parameter defines the voltage droop at 100% reactive current. The reactive current drooping in percentage of P2.1.1. Used in uGrid operation mode.

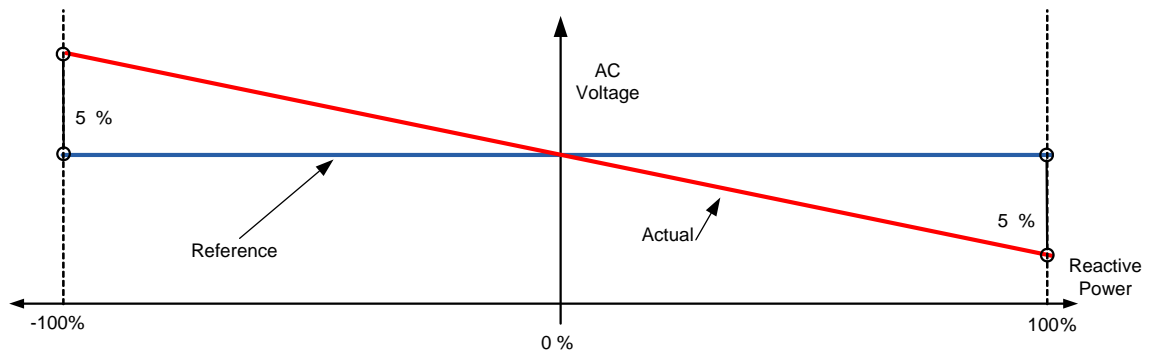

Figure 41.

2.11.4 *Start Power Mode* *ID 1503*

Defines how power is controlled to zero in Micro Grid mode.

0 = Zero Power OPT-D7

The option board D7 is used to monitor the grid frequency and uses this as a starting point for power drooping control.

1 = Zero Power from Supply Frequency

This selection is only possible with unit F19 and bigger.

The drive monitors the supply frequency by itself and uses this as a starting point for power drooping control.

2 = Drooping

The drive does not control the power to zero but goes directly to the drooping control with set parameters.

3 = Isochron Generator

The drive will follow the line frequency exactly, so the frequency change will not change the power of the Micro Grid application. In this mode, power is controlled by the base current reference.

2.11.5 *Voltage Rise Time* *ID 1541*

This parameter defines the time until the voltage is at nominal when the drive is started in Island mode or when in Micro Grid mode without an existing grid. Voltage Rise Time is used to minimize inrush current e.g. when Grid Converter needs to magnetize transformer on start.

6.10.1.1 Generator Simulation

These parameters are used to make drive operate more like diesel generator set.

P2.11.6 Generator Mechanical Time Constant *ID 1722*

Simulated diesel generator mechanical time constant.

Values above zero will enable diesel generator simulation function. Use 1000 ms as a starting point if actual mechanical time constant is not known.

P2.11.7 Generator Speed Control Kp *ID 1723*

Simulated diesel generator speed control gain.

P2.11.8 Generator Speed Control Ti *ID 1724*

Simulated diesel generator speed control Ti.

6.10.1.2 AFE operation mode selection

When using digital input P2.4.2.17 AFE Mode 2 and P2.4.2.18 AFE Mode 3 with the parameters below, it is possible to select the operation independently for both the digital inputs.

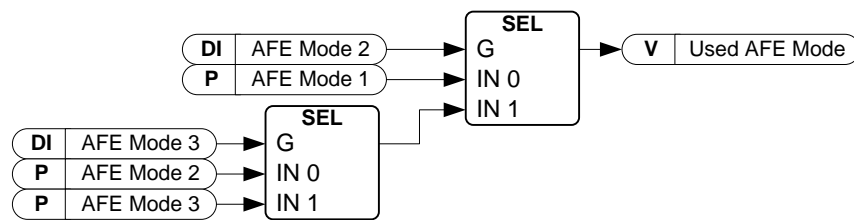

Figure 42.

2.11.10.1 AFE Mode 1 ID 1616

Only active when P2.11.1 is 6/Free select.

0= AFE

1= Island

2= Micro Grid

2.11.10.2 AFE Mode 2 ID 1617

Only active when P2.11.1 is 6/Free select.

0= AFE

1= Island

2= Micro Grid

2.11.10.3 AFE Mode 3 ID 1618

Only active when P2.11.1 is 6/Free select.

0= AFE

1= Island

2= Micro Grid

6.11 SYNCH TO EXTERNAL GRID

This function is used to synchronise to an external grid. Measurements with OPT-D7 are necessary for the use of this function.

2.12.1 *Synch. Offset* ID 1601

Used to compensate angle offset between the drive output terminals and OPT-D7 measurement point. E.g. with Dyn11, the transformer angle offset is usually 30.0 degree. This equals as 512 for this parameter. (3072 equals 180 degrees offset). If possible, run in AFE mode and see monitoring variable "D7 Synch. Error" to see what is needed for the offset.

$$\frac{x \text{ degree} * 3071}{180 \text{ degree}} = \text{Synch. Offset}$$

2.12.2 *Synch Reference* ID 1611

Use of P:Synch. Offset does not affect the error value that is shown in monitoring variable "D7 Synch. Error". Therefore you must give the reference for synchronization; usually this reference is roughly the same as P:"Synch. Offset" value, depending on the system. (3072 equals 180 degrees offset).

2.12.3 *Synch Kp* ID 1612

Island mode line sync gain. Init = 500.

2.12.4 *Synch Ti* ID 1613

Reserved (not in use)

2.12.5 *Synch.Hysteresis* ID 1614

Window for closing the net circuit breaker. (3172 equals 180 degrees).

2.12.6 *Contactor Delay* ID 1624

In case no feedback is received from the shore contactor, this can be used to simulate a feedback signal. That means that the control mode is changed after this time delay, after the command to close NET contactor has been given.

2.12.7 *Synch Stop Mode* ID 1618

Select operation after the drive has synchronised and received feedback from the shore contactor.

0 = Stay Run

1 = Stop

6.12 SYNCH TO SHAFT GENERATOR GRID**P2.13.1 SG follower Ramp Time ID 1527**

This is the ramp time when the grid side AFE follows the frequency of the shaft generator. This ramp time is activated when the frequency difference is below 0.10 Hz between the shaft generator and the drive.

P2.13.2 SG Grid Phase Offset ID 1586

Gives offset to the shaft generator angle when the phase synchronisation is activated.

P2.13.3 Synch Gain ID 1778

The phase synchronisation gain. The frequency reference at 180 degree difference.

P2.13.4 Phase Synch Ramp Time ID 1777

The ramp time for the synchronisation function. When the synchronisation mode is after the ramp, this time is active all the time.

If the synchronisation mode is before ramp, this time is activated when the angle difference is less than the value of Ramp Change Hyst.

P2.13.5 Max Synch Correction ID 1992

This parameter defines how much correction the phase synchronisation can make. The value 3070 equals to Synch Gain value.

P2.13.6 Ramp Change Hysteresis. ID 1894

This parameter defines the limit when the phase synchronisation starts to use the ramp time defined by P2.13.4. Before this, ramp time P2.3.1 is used.

6.13 ID FUNCTIONS

Here you will find the functions that use the parameter ID number to control and monitor the signal.

6.13.1 VALUE CONTROL

The value control parameters are used to control an input signal parameter.

P2.14.1.1 Control Input Signal ID *ID 1580* *"ContrInSignal ID"*

With this parameter you can select which signal is used to control the selected parameter.

P2.14.1.2 Control Off Limit *ID 1581* *"Contrl Off Limit"*

This parameter defines the limit when the selected parameter value is forced to Off value.

P2.14.1.3 Control On Limit *ID 1582* *"Contrl On Limit"*

This parameter defines the limit when the selected parameter value is forced to On value.

P2.14.1.4 Control Off Value *ID 1583* *"Contrl Off Value"*

This parameter defines the value that is used when the used input signal is below Off limit.

P2.14.1.5 Control On Value *ID 1584* *"Contrl On Value"*

This parameter defines the value that is used when the used input signal is above On limit.

P2.14.1.6 Control Output Signal ID *ID 1585* *"ContrlOutSignID"*

This parameter defines which parameter is forced to On and Off values when selected input signal exceeds the set limits.

P2.14.1.7 Control Mode *ID 1586* *"Control Mode"*

This parameter defines how the value control output behaves.

0 = SR ABS

Absolute input value is used to make a step change in the output between On and Off values.

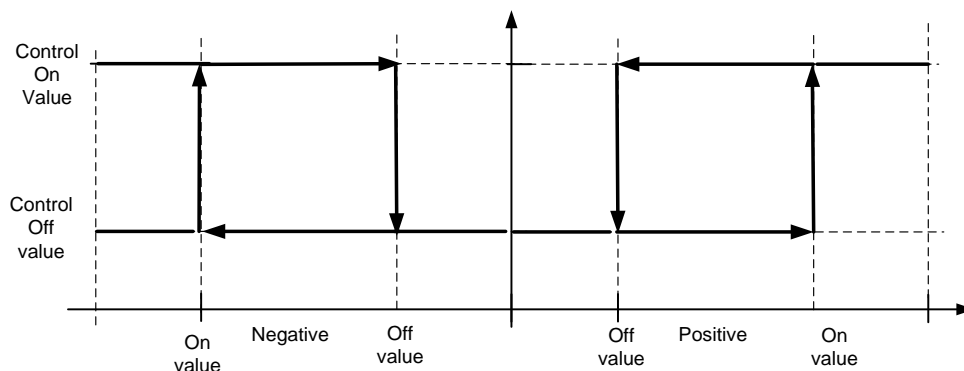

Figure 43.

1 = Scale ABS

Absolute input value is scaled linearly between On and Off values.

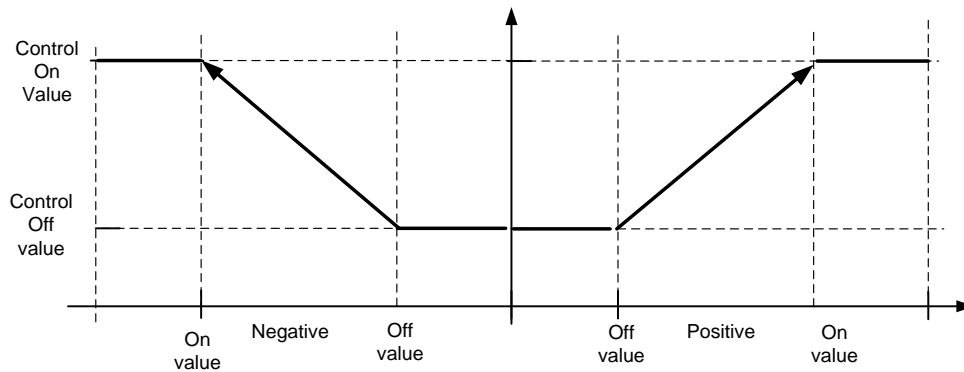

Figure 44.

2 = Scale ABS Inverted

Inverted absolute value is scaled linearly between On and Off values.

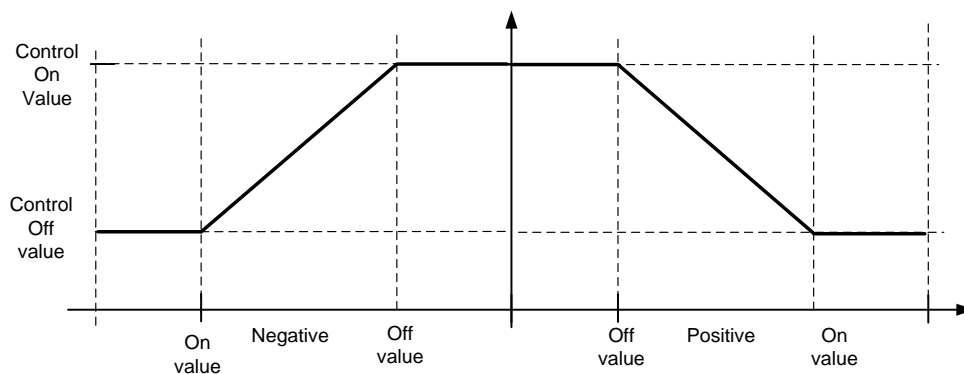

Figure 45.

3 = SR

Input value is used to make a step change in the output between On and Off values.

4 = Scale ABS

Input values is scaled linearly between On and Off values.

5 = Scale Inverted

Inverted value is scaled linearly between On and Off values

P2.14.1.8 Control Signal Filtering TC ID 1586 "Control Filt TC"

This parameter is used to filter the scaling function output. This can be used, for example, when unfiltered torque is used to control a parameter that needs stabilisation.

6.13.2 DIN ID CONTROL

This function is used to control any parameter between two different values with a digital input. Different values are given for DI LOW and DI HIGH.

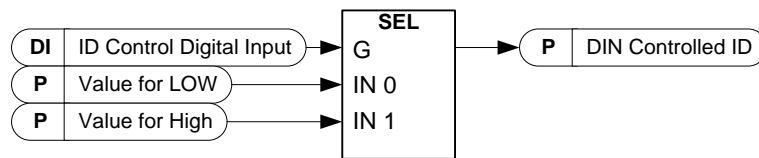

Figure 46.

<i>P2.14.2.1</i>	<i>ID Control Digital Input 1</i>	<i>ID 1570</i>	<i>"ID Control DIN"</i>
<i>P2.14.3.1</i>	<i>ID Control Digital Input 2</i>	<i>ID 1574</i>	<i>"ID Control DIN"</i>
<i>P2.14.4.1</i>	<i>ID Control Digital Input 3</i>	<i>ID 1578</i>	<i>"ID Control DIN"</i>
<i>P2.14.5.1</i>	<i>ID Control Digital Input 3</i>	<i>ID 1930</i>	<i>"ID Control DIN"</i>

Select a digital input to be used for controlling the parameter selected by ID1571.

<i>P2.14.2.2</i>	<i>DIN Controlled ID</i>	<i>ID 1571</i>	<i>"Controlled ID"</i>
<i>P2.14.3.2</i>	<i>DIN Controlled ID</i>	<i>ID 1575</i>	<i>"Controlled ID"</i>
<i>P2.14.4.2</i>	<i>DIN Controlled ID</i>	<i>ID 1579</i>	<i>"Controlled ID"</i>
<i>P2.14.5.2</i>	<i>DIN Controlled ID</i>	<i>ID 1931</i>	<i>"Controlled ID"</i>

Select a parameter ID controlled by ID1570.

<i>P2.14.2.3</i>	<i>Value for Low digital input (FALSE)</i>	<i>ID 1572</i>	<i>"FALSE Value"</i>
<i>P2.14.3.3</i>	<i>Value for Low digital input (FALSE)</i>	<i>ID 1576</i>	<i>"FALSE Value"</i>
<i>P2.14.4.3</i>	<i>Value for Low digital input (FALSE)</i>	<i>ID 1587</i>	<i>"FALSE Value"</i>
<i>P2.14.5.3</i>	<i>Value for Low digital input (FALSE)</i>	<i>ID 1932</i>	<i>"FALSE Value"</i>

Set the controlled parameter value when the digital input (ID1570) is LOW for the parameter selected by ID1571. The function does not recognise decimals. For example, give the value 10.00 Hz as *1000*.

<i>P2.14.2.4</i>	<i>Value for High digital input (TRUE)</i>	<i>ID 1573</i>	<i>"TRUE Value"</i>
<i>P2.14.3.4</i>	<i>Value for High digital input (TRUE)</i>	<i>ID 1577</i>	<i>"TRUE Value"</i>
<i>P2.14.4.4</i>	<i>Value for High digital input (TRUE)</i>	<i>ID 1588</i>	<i>"TRUE Value"</i>
<i>P2.14.4.4</i>	<i>Value for High digital input (TRUE)</i>	<i>ID 1933</i>	<i>"TRUE Value"</i>

Set the controlled parameter value when the digital input (ID1570) is HIGH for the parameter selected by ID1571. The function does not recognise decimals. For example, give the value 10.00 Hz as *1000*.

6.13.3 SIGNAL FAULT FUNCTION

P2.14.6.1 Fault Signal ID 0 ID1941

Select signal by ID number to be monitored for exceeding high or low limit.

P2.14.6.2 Fault Mode ID1942

Select response when signal exceeds set low or high limit.

P2.14.6.3 High Fault Limit ID1943

Set here the signal high limit when trigger is made for fault or warning. note the decimals are also needed from original signal. e.g. frequency limit 50,25 Hz is set as 5025.

P2.14.6.4 Low Fault Limit ID1944

Set here the signal low limit when trigger is made for fault or warning. Note the decimals are also needed from original signal. e.g. frequency limit 50,25 Hz is set as 5025.

6.14 AUTO RESET**P2.15.1 Wait Time** *ID 717*

Use this parameter to set a delay between the fault clearing and automatic fault reset.

P2.15.2 Trial Time *ID 718*

Use this parameter to specify the duration for supervising measurements and signals for fault clearing.

P2.15.3 Overvoltage Tries *ID 721*

Use this parameter to define the amount of auto reset tries for an overvoltage fault.

P2.15.4 Overcurrent Tries *ID 722*

Use this parameter to define the amount of auto reset tries for an overcurrent fault.

P2.15.5 External Fault Tries *ID 725*

Use this parameter to define the amount of auto reset tries for an external fault.

6.15 GRID VOLTAGE PI CONTROLLER

The PI controller is meant to help keep the line voltage constant when the load changes. The OPT-D7 option board is necessary. The PI controller controls the field weakening voltage point to keep a constant voltage on the line.

When OPT-D7 board is not used, it is possible to use Analogue Input 3 and 4 ID write function to give the grid the Line Frequency D7 (ID1654) and Line Voltage D7 (ID1650). This enables use of grid PI voltage controller without the OPT-D7 board. Note that both line frequency and line voltages needs to be given.

P2.15.1 PI Activation *ID 1807*

Select the digital input that will activate the PI controller. Set selection to 0.2 and the PI controller is activated without an external wiring.

P2.15.2 PI Controller Gain *ID 118*

This parameter defines the gain of the PID controller. If the value of the parameter is set to 100%, a change of 10% in the error value causes the controller output to change by 10%. If the parameter value is set to 0, the PID controller operates as an I controller.

P2.15.3 PI Controller I-time *ID 119*

The parameter ID119 defines the integration time of the PID controller. If this parameter is set to 1.00 second, a change of 10% in the error value causes the controller output to change by 10.00%/s. If the parameter value is set to 0.00 s, the PID controller will operate as a P controller.

P2.15.4 PI Max Adjust *ID 360*

This parameter defines maximum adjustment that PI controller can made to voltage.

6.15.1 GRID VOLTAGE PI OPT-D7 LIMITS

These parameters define the limits within which the OPT-D7 measurements must remain in order for the PI controller to remain active. This is a protection function in case of a measurement loss. When a measurement loss is detected, the drive will not stop, but instead it continues to operate by using open loop voltage compensation (Inductor Size and Losses).

P2.16.5.1 PI Frequency Low Limit *ID 1630*

P2.16.5.2 PI Frequency High Limit *ID 1631*

P2.16.5.3 PI Voltage Low Limit *ID 1632*

P2.16.5.4 PI Voltage High Limit *ID 1633*

7. KEYPAD CONTROL PARAMETERS

Unlike the parameters listed above, these parameters are located in the **M3** menu of the control panel. The reference parameters do not have an ID number.

P3.1 Control Place ID 125 “Control Place”

The active control place can be changed with this parameter. PC Control place can be only activated when from NCDrive when this parameter is set 2 / Keypad.

0 = PC Control, Activated by NCDrive

1 = I/O terminal

2 = Keypad

3 = Fieldbus

4 = SystemBus

On keypad control pressing Stop button more than a 2 second will open the MCB.

P3.2 Licence Key ID 1995 “Licence Key”

Enter the licence key.

The standard AFE functions are available without a licence key. A licence key is not necessary for the frame FR4.

8. FB STATUS AND CONTROL IN DETAIL

P2.10.19 State machine	
1 / Basic	This mode makes fieldbus control operate as is explained in the fieldbus board manual.
2 / Standard	Simple control word that is used in modes where the control word from fieldbus is used as such. For some fieldbus boards this requires bypass operation.
3 / Vacon AFE 1	This mode uses a ProfiDrive type state machine in the application level. It is possible to use this mode on fieldbus boards that do not have a state machine or have a possibility to bypass the state machine function on the option board.
3 / Vacon AFE 2	

8.1 FB DC REFERENCE

Fieldbus DC reference is available when the Grid Converter is in fieldbus control. The format is the same as in panel references. (11000 = 110 %). If reference is not used from fieldbus, set the "FBSpeedReference" to zero. When FB reference is zero, the drive will use DC Voltage Reference from keypad parameter.

8.2 STATE MACHINE: BASIC**8.2.1 FB CONTROL WORD BASIC***Table 54.*

FB Control Word: Basic			
	FALSE	TRUE	Comment
b0	Stop Request	Start Request	Use this for start and stop command
b1			
b2	No Action	Fault Reset 0 > 1	Use this for fault reset
b3	Fieldbus DIN1=OFF	Fieldbus DIN1=ON	See P2.5.1.17 -18
b4	Fieldbus DIN2=OFF	Fieldbus DIN2=ON	See P2.5.1.19 -20
b5	Fieldbus DIN3=OFF	Fieldbus DIN3=ON	See P2.5.1.21 -22
b6	Fieldbus DIN4=OFF	Fieldbus DIN4=ON	See P2.5.1.23 -24
b7			
b8			
b9			
b10			
b11			
b12			
b13			
b14			
b15			

B00: FALSE = Stop Request, TRUE = Start Request

Stop Request: Drive will stop modulating

Start Request: Drive will start modulating, rising edge needed after fault situation.

B02: FALSE = No Action, TRUE = Fault Reset

Fault Reset: Resets active faults.

8.3 STATE MACHINE: STANDARD**8.3.1 CONTROL WORD: STANDARD***Table 55.*

FB Control Word Standard			
	FALSE	TRUE	Comment
b0	Open CB	Charge DC	
b1			
b2			
b3	Stop Request	Run Request	Use this for start and stop command
b4			
b5			
b6			
b7	No Action	Fault Reset 0 > 1	Use this for fault reset
b8			
b9			
b10			
b11	Fieldbus DIN1=OFF	Fieldbus DIN1=ON	See P2.5.1.17 -18 also WD Pulse
b12	Fieldbus DIN2=OFF	Fieldbus DIN2=ON	See P2.5.1.19 -20
b13	Fieldbus DIN3=OFF	Fieldbus DIN3=ON	See P2.5.1.21 -22
b14	Fieldbus DIN4=OFF	Fieldbus DIN4=ON	See P2.5.1.23 -24
b15			

B00: FALSE = Open CB, TRUE = Charge DC

Open CB: The drive will stop modulating and open main circuit breaker.

Charge DC: The drive will start to precharge if the function is activated by a digital output and the control place is fieldbus. When charging is ready, the main circuit breaker is closed depending on "CB Close Mode" and "Enable CB Close" status.

When the control place is not fieldbus, precharge is started at a normal start command.

B03: FALSE = Stop Request, TRUE = Start Request

Stop Request: The drive will stop.

Start Request: Start Command to the drive.

B07: FALSE = No Action, TRUE = Fault Reset

Fault Reset: Resets active faults.

8.4 STATE MACHINE: VACON AFE 1

8.4.1 CONTROL WORD: VACON AFE 1

FB Control Word Vacon AFE 1			
	FALSE	TRUE	Comment
b0	Open CB	Charge DC	
b1			
b2			
b3	Stop Request	Run Request	Use this for start and stop command
b4			
b5			
b6			
b7	No Action	Fault Reset 0 > 1	Use this for fault reset
b8			
b9			
b10	Field Bus Control Disable	Fieldbus Control Enable	
b11	Watchdog pulse FALSE	Watchdog pulse TRUE	0>1>0>1...0.5 sec square wave clock. This is used to check data communication between fieldbus master and the drive.
b12	Fieldbus DIN2=OFF	Fieldbus DIN2=ON	See P2.5.1.19 -20
b13	Fieldbus DIN3=OFF	Fieldbus DIN3=ON	See P2.5.1.21 -22
b14	Fieldbus DIN4=OFF	Fieldbus DIN4=ON	See P2.5.1.23 -24
b15			

B00: FALSE = Open CB, TRUE = Charge DC

Open CB: The drive will stop modulating and open main circuit breaker.

Charge DC: The drive will start to precharge if the function is activated by a digital output and the control place is fieldbus. When charging is ready, the main circuit breaker is closed depending on "CB Close Mode" and "Enable CB Close" status.

When the control place is not fieldbus, precharge is started at a normal start command.

B03: FALSE = Stop Request, TRUE = Start Request

Stop Request: The drive will stop.

Start Request: Start Command to the drive.

B07: FALSE = No Action, TRUE = Fault Reset

Fault Reset: Resets active faults.

B10: FALSE = FB Control disabled TRUE = FB Control Enabled

FB Control Disabled: The drive will not follow the main control word from fieldbus. If removed while running, the drive will stop.

FB Control Enabled: The drive follows the control word from fieldbus.

B11: FALSE = FB WD Pulse Low, TRUE = FB WD Pulse High

Watchdog pulse: This pulse is used to monitor that PLC is alive. If the pulse is missing, the drive will go to FAULT state. This function is activated by P2.9.4.3 FB WD Delay. When the value is zero, the pulse is not monitored.

8.5 CONTROL WORD: VACON AFE 2 PROFILE (3)

FB Control Word ID1160		
	Signal	Comment
B00	DC Charge	0= Open MCB. 1= Close DC charge contactor, MCB closed automatically, see B01.
B01	MCB Close Enable	0= Disable Closing of MCB (Also opens if Control Options.B0=TRUE) 1= Enable Closing of MCB (Works also for reclosing)
B02	Quick Stop	0= Quick Stop 1= No Quick Stop
B03	Run	0= AFE is stopped 1= AFE is started
B04	Output Power Limit to Zero	0= Output Power Limit to Zero (7%) 1= Output Power Limit = P2.5.2.1
B05	Disable Power Increase. Input or Output	0= Disable increase of power. 1= Power limits defined by G2.5.2
B06	Input Power Limit to Zero	0= Input Power Limit to Zero (7%) 1= Output Power Limit = P2.5.2.2
B07	Reset	0>1 Reset fault.
B08	DC Voltage Ref B00	B00 B01 0 0 = FB Reference. P2.2.1, if not FB Control & FB Ref > 50,00 % 0 1 = 110 %
B09	DC Voltage Ref B01	1 0 = 115 % 1 1 = 120 %
B10	Fieldbus Control	0= No control from fieldbus 1=Control from fieldbus
B11	Watchdog	0>1>0>1...0,5 sec square wave clock. This is used to check data communication between fieldbus master and the drive.
B12	FB DIN2	Can be used to control RO or directly parameter by ID number. G2.4.1
B13	FB DIN3	Can be used to control RO or directly parameter by ID number. G2.4.1
B14	FB DIN4	Can be used to control RO or directly parameter by ID number. G2.4.1
B15		Reserved for future use.

Figure 47.

B00: FALSE = Open MCB, TRUE = PreCharge DC

Open MCB: Opens MCB if closed, stops precharging if charging is active through the drive.

PreCharge DC: Drive will start precharge if function activated by digital output and control place is fieldbus. When control place is not fieldbus precharging is started from normal start command.

B01: MCB Close Enable

FALSE: MCB Closing is disabled in fieldbus control. MCB Remains open when if DC voltage is above closing limit.

TRUE: MCB Closing is enabled in fieldbus control. This bit can be true all the time if function is not needed.

B02: Quick Stop

FALSE: Drive will stop modulation immediately and open MCB immediately.

TRUE: Quick stop is not active and normal operation is possible.

B03: FALSE = Stop Request, TRUE = Start Request

Stop Request: Drive will stop .

Start Request: Start Command to the drive. Rising edge needed for start.

B04: Output Power Limit to Zero

FALSE: Output power limit is reduced to 7 % if parameter limit is higher.

TRUE: Power limit is defined by power limit parameters.

B05: Disable Power Increase. Input or Output

FALSE: Power is limited to actual power, power can't increase when this bit is active,

TRUE: Power limit is defined by power limit parameters.

B06: Input Power Limit to Zero

FALSE: Input power limit is reduced to 7 % if parameter limit is higher

TRUE: Power limit is defined by power limit parameters.

B07: FALSE = No significance, TRUE = Fault Acknowledge

Fault Acknowledge: The group signal is acknowledged with a positive edge.

B08: FALSE = No Function, TRUE = DC Ref 1

B09: FALSE = No Function, TRUE = DC Ref 2

DC Ref	FB Reference	110,00 %	115,00 %	120,00 %
B08	FALSE	TRUE	FALSE	TRUE
B09	FALSE	FALSE	TRUE	TRUE

B10: FALSE = FB Control disabled TRUE = FB Control Enabled

FB Control Disabled: Drive will not follow main control word from Fieldbus. If removed while running drive will make coasting stop.

FB Control Enabled: Drive follows control word from fieldbus

B11: FALSE = FB WD Pulse Low, TRUE = FB WD Pulse High

Watch dog pulse: This pulse is used to monitor that PLC is alive. If pulse is missing drive will go to fault state. This function is activated by P2.7.6 FB WD Delay. When value is zero pulse is not monitored.

8.6 FB STATUS WORD

FB Status Word ID68			
	FALSE	TRUE	Comment
b0	DC Charge Disabled	Ready to DC Charge	Drive own DC charge function disabled if FALSE
b1	Not ready to operate	Ready to operate	DC Charged and main CB closed.
b2	Not Running	Running	Drive in Run state
b3	No Fault	Fault	Fault Active
b4	Run Disabled	Run Enabled	Run Enable
b5	Quick stop active	Quick stop not active	Quick stop active
b6	CB Control OK	CB Control NOT OK	CB Requested open but DC stays high
b7	No Warning	Warning	Warning Active
b8	DC Act. <> DC Ref.	DC Act. = DC Ref.	DC at reference
b9	No FB Control request	FB Control Active	FB Control request accepted
b10	DC Below Limit	DC Above Limit	DC above set limit
b11	SW ID.Bit selection B11	P2.13.22 SW B11 ID.Bit	SW ID.Bit selection B11
b12	SW ID.Bit selection B12	P2.13.23 SW B12 ID.Bit	SW ID.Bit selection B12
b13	SW ID.Bit selection B13	P2.13.24 SW B13 ID.Bit	SW ID.Bit selection B13
b14	SW ID.Bit selection B14	P2.13.25 SW B14 ID.Bit	SW ID.Bit selection B14
b15	Watchdog feedback	Watchdog feedback	WD Feedback pulse

SM = Profibus board State Machine

B00: FALSE = DC Charge Disabled, TRUE = Ready to DC Charge

DC Charge Disabled: Fault active, CB requested open, for example, by “Open CB” Command or Quick Stop.

DC Charge Enabled: No fault active and no request to open CB.

B01: FALSE = Not Ready To Operate, TRUE = Ready To Operate

Not Ready To Operate: CB not closed or not allowed to close.

Ready To Operate: CB closed.

B02: FALSE = Drive is not operating, TRUE = Drive is operational

Drive is not operating: The drive is not in RUN state (not modulating)

Drive is operational: The drive is in RUN state and modulating.

B03: FALSE = No Fault, TRUE = Fault Present

No Fault: The drive is not on FAULT state.

Fault Present: The drive is in FAULT state.

B04: FALSE = Run Disabled, TRUE = Run Enabled

Run Disabled: The drive does not receive Run Enable command, for example from the Run Enable digital input.

Run Enabled: Run Command is enabled.

B05: FALSE = Quick Stop Activated, TRUE = Quick Stop Not Activated

Quick Stop Activated: Quick Stop command is active.

Quick Stop Not Activated: Quick stop command is not active.

B06: FALSE = CB Control OK, TRUE = CB Control Not OK

CB Control OK: CB control and the drive internal status are the same.

CB Control Not OK: The drive internal status to close the circuit breaker is high but the application logic requests for the circuit breaker to open. This can be the case when CB has been opened but DC is connected to battery system. DC must be discharged or CB must close.

B07: FALSE = No Warning, TRUE = Warning Present

No Warning: There is no warning or the warning has disappeared again.

Warning Present: The drive operates, but there is an active warning.

B08: FALSE = DC Voltage out of tolerance TRUE = DC Voltage within tolerance

DC Error Out Of Tolerance Range

DC Error Within Tolerance Range

B09: FALSE = No Control Requested, TRUE = Control Requested

No Control Requested: Control by the automation system is not possible, only possible at the device or by another interface.

Control Requested: The automation system is requested to assume control.

B10: FALSE = DC Not Reached, TRUE = DC Reached Or Exceeded

DC Not Reached: DC is below P2.5.7.4 DC Voltage Supervision Limit.

DC Reached Or Exceeded: DC is above P2.5.7.4 DC Voltage Supervision Limit.

B11: FALSE = SW ID.Bit selection B11, TRUE = SW ID.Bit selection B11

SW ID.Bit selection B11 Low: Selected bit is low.

SW ID.Bit selection B11 High: Selected bit is high.

B12: FALSE = SW ID.Bit selection B12, TRUE = SW ID.Bit selection B12

SW ID.Bit selection B12 Low: Selected bit is low.

SW ID.Bit selection B12 High: Selected bit is high.

B13: FALSE = SW ID.Bit selection B13, TRUE = SW ID.Bit selection B13

SW ID.Bit selection B13 Low: Selected bit is low.

SW ID.Bit selection B13 High: Selected bit is high.

B14: FALSE = SW ID.Bit selection B14, TRUE = SW ID.Bit selection B14

SW ID.Bit selection B14 Low: Selected bit is low.

SW ID.Bit selection B14 High: Selected bit is high.

B15: FALSE = FB DW Feedback Low, TRUE = FB DW Feedback High

FB DW Feedback: FB Control Word B11 is echoed back to the fieldbus. Can be used to monitor the communication status from the drive.

8.7 FB MICRO GRID CONTROL WORD 1 ID1700

FB Micro Grid CW1 ID1700		
	Signal	Comment
b0	Start As Island	If B11 = False, mode changed in STOP state.
b1	Start As Micro Grid	If B11 = False, mode changed in STOP state.
b2	Start synchronisation D7	Synchronization to external grid with OPT-D7
b3		
b4	Power Down	Same as P2.2.6.2
b5	Power Up	Same as P2.2.6.3
b6	Reset MotPot	Same as P2.4.2.27
b7		
b8		
b9		
b10	Enable FB Control Mode	B0 and B1, is controllable from FB otherwise parameter
b11	Live Mode Control	Operation mode is changed in Run State
b12	P2.10.27 uCW B12	
b13	P2.10.28 uCW B12	
b14	P2.10.29 uCW B12	
b15	P2.10.30 uCW B12	

9. PROBLEM SOLVING

While proper information is needed from the problem, it is also recommended to try with latest application- and system software versions available. Software is continuously developed and default settings are improved (See Chapter 1.13 Compatibility issues in parameters between versions).

Type	Signal Name	Actual	Unit	Min
Value	Status Word	6134		
Value	DC Voltage Act.	120		
Value	Active Current	9,3		
Value	Reactive Current	6,3		
Value	Supply Frequency	60	Hz	45,00
Value	Supply Voltage	389,9	V	300,0
Value	LineFrequency D7	-60	Hz	45,00
Value	Line Voltage D7	400	V	300

Figure 48. The recommended signals for NCDrive

Use the fastest communication speed (Baudrate: 57 600) and a 50 ms update interval for signals for the RS232 communication.

For the CAN communication, use a 1 Mbit communication speed and a 7 ms update interval for signals.

When you contact the support, send the *.trn, *.par and Service info (*.txt) files with a description of the situation. If the situation is caused by a fault, take also the Datalogger data from the drive.

Note that Datalogger settings can be changed to catch correct situation and it is also possible to make manual force trig for Datalogger.

Before storing the parameter file, upload the parameters from the drive and save when NCDrive is in the ON-LINE state. If it is possible, do this while the problem is active.

It is also helpful to have a single line diagram from the system where problem is faced.

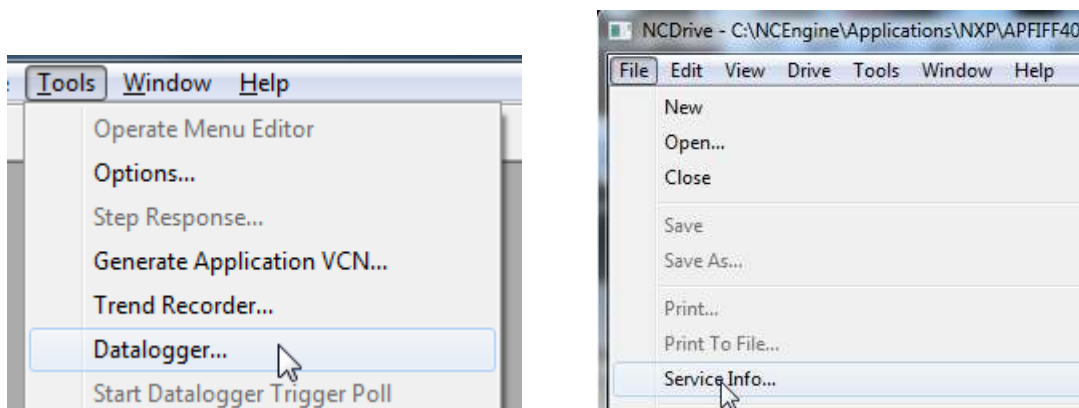

Figure 49. Datalogger window opening and Service Info upload.

10. FAULT CODES

This chapter includes all the fault codes. However, some faults are not possible in the AFE mode. With other faults, the description can be different when compared to a standard AC drive.

F1 Over current fault

The drive has detected a high current in the output phase.

S1 = Hardware trip.

Current above $4 \cdot I_h$

S3 = Current controller supervision.

Current limit too low or current peak value too high.

Possible cause

- Sudden change in grid frequency.
- Sudden change in grid voltage.
- Short circuit in grid while Short Circuit function is not active.

Correcting measures

- Check grid conditions load.
- Activate Short Circuit function.

F2 Overvoltage fault

DC link voltage has exceeded the drive protection limits.

S1 = Hardware trip.

500 Vac unit DC voltage above 911 Vdc

690 Vac unit DC voltage above 1200 Vdc

S2 = Overvoltage control supervision (only 690 Vac unit).

DC voltage has been above 1100 Vdc for too long.

Possible cause and solutions

- Sudden change in supply voltage or frequency.
- Unstable DC power source in uGrid mode.
- Wrong Grid frequency.

Correcting measures

- Check supply voltage.
- Check DC source.
- Check grid conditions.

F3 *Earth fault*

Earth fault protection makes sure that the sum of the motor phase currents is 0. The over current protection is always working and protects the AC drive from earth faults with high currents.

S1 = Sum of output phase current is not zero.

Possible cause

- No transformer on the input/output side.
- Insulation failure.

Correcting measures

- Contact factory.

F5 *Charge switch*

Charge switch status is not correct when the start command is given.

S1 = Charge switch was open when the start command was given.

Possible cause

- Charge switch was open when the start command was given.
- Reset the fault and restart.

Correcting measures

- Check the connection of the feedback from charging relay
- If the fault re-occurs, contact your local distributor.

F6 *Emergency stop*

Emergency stop command has been given by using a special option board.

F7 *Saturation fault*

S1 = Hardware failure.

Possible cause and solutions**Correcting measures**

- Check the isolation resistance and the resistance on the brake resistor.
- Check the capacitors.

F8 System Fault

A system fault indicates that there are several different fault situations in the drive operation.

S1 = Reserved

- Disturbance. Reset the unit and try again.
- If there is star coupler in the unit, check the fibre connections and phase order.
- Driver board or IGBT is broken.
- FR9 and the bigger drives, which includes not star coupler, ASIC board (VB00451), is broken.
- FR8 and smaller drives: control board is broken.
- FR8 and smaller drives: if there are boards VB00449 / VB00450, the fault can be there.

S2 = Reserved

S3 = Reserved

S4 = Reserved

S5 = Reserved

S6 = Reserved

S7 = Charge switch

S8 = No power to driver card

S9 = Power unit communication (TX)

S10 = Power unit communication (Trip)

S11 = Power unit comm. (Measurement)

S12 = SystemBus synchronisation has failed in DriveSynch operation

S30 = Safe disable inputs are in different state (OPT-AF)

S31 = Thermistor short circuit detected (OPT-AF)

S32 = OPT-AF board has been removed

S33 = OPT-AF board EEPROM error

Possible cause and solutions

Correcting measures

F9 Undervoltage fault

DC link voltage is below the fault voltage limit of the drive.

S1 = DC link too low during the run.

S2 = No data from the power unit.

S3 = Undervoltage control supervision.

Possible cause

- Too low a supply voltage.
- AC drive internal fault.
- One of the input fuses is broken.
- External charge switch has not been closed.

Correcting measures

- In case of temporary supply voltage break, reset the fault and restart the AC drive.
- Check supply voltage.
- Check the operation of the DC charge.
- Contact your local distributor.

F10 Line Synchronization Fault

S1 = Phase supervision diode supply.

S2 = Phase supervision active front end.

S3 = Grid Converter operation, frequency outside frequency limits (G2.6.3).

Possible cause:

- Input line phase is missing.
- No grid to be synchronized
- Slow power increase in a grid and limit controllers has activated.
- Power or current limits too low for the active load.

Correcting measures

- Check supply voltage, fuses and cable.
- Check drive dimensioning against grid power requirements.
- Check that power or current limits are sufficient.

F11 Line phase supervision

Possible cause:

- Current measurement has detected that there is no current in one phase, or one phase current is considerably different from other phases.

Correcting measures

- Check the motor cable and the motor.

F12 Brake chopper supervision

Brake chopper supervision generates pulses to the brake resistor for response. If no response is received within set limits, a fault is generated.

Possible cause:

- No brake resistor is installed.
- The brake resistor is broken.
- Brake chopper failure.

Correcting measures:

- Check the brake resistor and the cabling.
- If these are ok, the chopper is faulty. Contact your local distributor.

F13 Drive undertemperature fault

Possible cause:

- Heatsink temperature is under -10°C

Correcting measures:

- Add cabinet heater to prevent too cold temperatures and condensation.

F14 Drive overtemperature fault

Possible cause:

- Heatsink temperature is above the acceptable limits. See the user manual for the temperature limit. Overtemperature warning is issued before the actual trip limit is reached.

Correcting measures

- Check correct amount and flow of cooling air.
- Check the heatsink for dust.
- Check ambient temperature.
- Make sure that switching frequency is not too high in relation to ambient temperature and motor load.

F22 EEPROM checksum fault

Possible cause:

- Parameter save fault.
- Faulty operation.
- Component failure.

Correcting measures:

- If the fault re-occurs, contact your local distributor.

F24 Counter fault**Possible cause:**

- Values displayed on the counters are incorrect.

Correcting measures:

- Have a critical attitude towards values shown on the counters.

F25 Microprocessor watchdog fault**Possible cause:**

- Start-up of the drive has been prevented.
- Run request is ON when a new application is loaded to the drive.

Correcting measures:

- Reset the fault and restart.
- If the fault re-occurs, contact your local distributor.

F26 Start-Up prevention**Possible cause:**

- Start-up of the drive has been prevented.
- Run request is ON when a new application is loaded to drive

Correcting measures:

- Cancel the prevention of the start-up if this can be done safely.
- Remove Run Request.

F29 Thermistor fault

The thermistor input of the option board has detected too high a motor temperature.

Possible cause:

- LCL is overheated.
- Thermistor cable is broken.

Correcting measures:

- Check LCL cooling and load.
- Check thermistor connection (If thermistor input of the option board is not in use it has to be short circuited).

F31 IGBT temperature

IGBT Inverter Bridge overtemperature protection has detected too high a short term overload current.

Possible cause:

- Too high a load.
- Identification run has not been made, which causes the motor to start undermagnetised.

Correcting measures:

- Check the load.
- Check the motor size.
- Make an Identification Run.

F32 Fan cooling**Possible cause:**

- Cooling fan of the AC drive does not start when ON command is given.

Correcting measures:

- Contact your local distributor.

F37 Device change

Option board or power unit is changed.

Possible cause:

- New device of same type and rating.

Correcting measures:

- Reset. The device is ready for use.

F38 Device added

Option board is added.

Correcting measures:

- Reset. The device is ready for use. Old board settings will be used.

F39 Device removed**Possible cause:**

- Option board is removed.

Correcting measures:

- Reset. The device is no longer available.

F40 *Device unknown*

An unknown option board or drive.

S1 = Unknown device.

S2 = Power1 not same type as Power2.

Correcting measures:

- Contact your local distributor.

F41 *IGBT temperature*

IGBT inverter bridge overtemperature protection has detected too high a short term overload current.

Correcting measures:

- Check the load.
- Check the motor size.
- Make an Identification Run.

F42 *Brake resistor overtemperature*

S1: Brake resistor high temperature.

Calculation for an internal brake resistor has exceeded the tripping limit. If the internal brake resistor is not in use, set the brake chopper parameter in System menu to *Not connected*.

S2: Brake resistor resistance is too high.

S3: Brake resistor resistance is too low.

S4: No brake resistor detected.

F44 *Device changed (Default param.)*

Possible cause:

- Option board or power unit is changed.
- New device of different type or different rating from the previous one.

Correcting measures:

- Reset.
- Set the option board parameters again if option board was changed. Set the drive parameters again if the power unit was changed.

F45 *Device added (default param.)*

Possible cause:

- Option board of different type added.

Correcting measures:

- Reset.
- Set the option board parameters again.

F50 *4mA supervision*

Possible cause:

- Current at the analogue input is below 4mA.
- Signal source has failed.
- Control cable is broken or loose.

Correcting measures:

- Check the current loop circuitry.

F51 *External fault*

Possible cause:

- Digital input fault.

Correcting measures:

- Remove fault situation from the external device.

F52 *Keypad communication*

Possible cause:

- The connection between the control panel (Keypad) or NCDrive and the AC drive is broken.

Correcting measures:

- Check control panel connection and possible control panel cable.

F53 *Fieldbus communication fault on slot D*

Possible cause:

- The data connection between the fieldbus Master and the fieldbus board is broken.
- Watchdog pulse is missing from PLC, if Control Slot selector is 0, or set for slot D.

Correcting measures:

- Check installation.
- If installation is correct, contact your local distributor.

F54 *Slot fault*

Possible cause:

- Defective option board or slot.

Correcting measures:

- Check the board and the slot.
- Contact your local distributor.

F56 PT100 temperature fault

The PT100 protection function is used to measure temperature and give a warning and/or a fault when the set limits are exceeded. The marine application supports two PT100 boards. One can be used for the motor winding and the other for the motor bearings.

Possible cause:

- Temperature limit values set for the PT100 board parameters have been exceeded.

Correcting measures:

- Find the cause of temperature rise.

F57 Identification (Not implemented)

Identification run has failed.

Possible cause:

- There was load on the motor shaft when making the identification run with a rotating motor.
- Motoring or generator side torque/power limits are too low to achieve a stable run.

Correcting measures:

- Run command was removed before the identification was ready.
- Motor is not connected to the AC drive.
- There is load on the motor shaft.

F58 Mechanical brake (Not implemented)

This fault is generated when the acknowledge signal from the brake is used. If the status of the signal is opposite from the control signal for a longer period of time than the delay defined with P2.15.11 *Brake Fault Delay*, a fault is generated.

Correcting measures:

- Check the condition and connections of the mechanical brake.

F59 SystemBus communication

The master drive sends pulses to all follower drives. If the pulses are missing, a system bus communication fault is generated. The master drive also receives pulses back from the follower drives (max. four drives) and generates warnings if pulses are missing.

SystemBus communication is broken between master and follower.

Correcting measures:

- Check expander board parameters.
- Check optical fibre.
- Check option board jumpers.

F60 Cooling

Protection for the liquid-cooled units. An external sensor is connected to the drive (DI: Cooling Monitor) to indicate if cooling liquid is circulating. If the drive is in STOP state, only a warning is issued. In RUN state a fault is issued and the drive makes a coast stop.

Possible cause:

- The cooling circulation of a liquid-cooled drive has failed.

Correcting measures:

- Check reason for cooling failure from the external system.

F62 Run Disabled

A Run Disable warning signal is issued when a Run Enable signal has been removed from the I/O.

F63 Quick stop

Possible cause:

- A command has been given from a digital input or the fieldbus to make a quick stop.

Correcting measures:

- A new run command is accepted after the quick stop is reset.

F64 MCB State Fault

This function monitors the MCB status. Feedback status should correspond to the control signal. The delay to fault is defined by P2.9.1.13 MCB Fault Delay for A2 and A3. A4 is immediately.

A1: Code given by V084 and older versions.

A2: MCB open while request is to close.

A3: MCB closed while request is to open.

A4: MCB opened externally while AFE unit was in run state.

Possible cause:

- Main circuit breaker has opened while drive controls it to close.
- Main circuit breaker has closed while drive controls it to be open.

Correcting measures:

- Check the main circuit breaker function.

F65 PT100 board 2

The PT100 protection function is used to measure temperature and give a warning and/or a fault when the set limits are exceeded. The marine application supports two PT100 boards. One can be used for the motor winding and the other for the motor bearings.

Possible cause:

- The temperature limit values set for the PT100 board parameters have been exceeded.
- The number of inputs selected is higher than what is actually connected.
- PT100 cable is broken.

F67 Fieldbus communication fault on slot E**Possible cause:**

- The data connection between the fieldbus Master and the fieldbus board is broken.
- Watchdog pulse is missing from PLC, if Control Slot Selector is 0, or set for slot E.

Correcting measures:

- Check installation.
- If installation is correct contact your local distributor.

F68 D7 Voltage or frequency fault

This monitors Grid frequency and voltage for synchronization function.

Possible cause:

- OPT-D7 measurements are not within limits.

F69 OPT-D7 Missing

OPT-D7 board is not present for the function that is requested.

Possible cause:**Correcting measures:*****F70 Supply Voltage***

Supply voltage is not inside of set hysteresis. Not to be confused with OPT-D7 protections.

F71 LCL Temperature

LCL Temperature has reached the warning limit.

Possible cause:**Correcting measures:*****F72 Licence***

Licence has not been given or licence key is wrong

Possible cause:**Correcting measures:**

F73 Supply Frequency

Supply frequency is not inside of set hysteresis, set in G2.9.7. Not to be confused with OPT-D7 protections that will give F93 D7 Frequency.

Possible cause:

- Slow power increase in a grid and limit controllers activated.
- Power or current limits too low for the active load.
- Not sufficient DC voltage to keep grid voltage, compensated by lowering Supply Frequency to avoid reactive current.

Correcting measures

- Check drive dimensioning against grid power requirements.
- Check that power or current limits are sufficient.
- Check that sufficient DC voltage is available for the unit.

F80 Charging Fault

The drive has not reached the required DC voltage at time set to MCB.

Possible cause:

- Charging circuit not operational.
- High load in DC link.
- Low voltage in supply for charging circuit.

Correcting measures:

- Check charging current

F81 External Fault 2

Digital input fault.

Possible cause:

Correcting measures:

- Remove fault situation from external device.

F82 Start Failed

MF mode second drive has not started within set time.

Possible cause:

Correcting measures:

F83 Over Load

Over Load protection has reached tripping limit. See Chapter 5.9.9 Over Load Protection.

F89 Grid Side Fault

In Master-Follower Mode Grid side drive has an active fault that is shown in master drive as a fault.

Possible cause:

Correcting measures:

F91 Short Circuit

Drive has operated against current limit for more than short circuit time.

By phase fault detection has seen low voltage for more than short circuit time.

Warning comes immediately when current is at current limit, fault comes after the short circuit time.

A1: Code given by V089 and older versions.

A2: Bi Phase

A3: Three Phase

Possible cause:

- There is a short circuit in the grid.

Correcting measures:

F92 D7 Voltage

Measured voltage is not within limits set in the protection group Grid Voltage D7

Possible cause:

- Voltage reference is below set limit.
- Supply Voltage is below set limit.
- There is a short circuit in the grid.
- OPT-D7 is installed but not connected.
 - Monitoring can be disabled with Control Options.

F93 D7 Frequency

Measured frequency is not within limits set in protection group Grid Frequency.

Possible cause:

- OPT-D7 is installed but measurements are not connected.
 - Monitoring can be disabled with Control Options.
- Grid frequency has gone outside the set limits.

VACON®

www.danfoss.com

Vacon Ltd
Member of the Danfoss Group
Runsorintie 7
65380 Vaasa
Finland

Document ID:



Rev. B

Sales code: DOC-GRIDCONV+DLUK